

IBM 3745 Communication Controller
Models 130, 150, 160, 170 and 17A

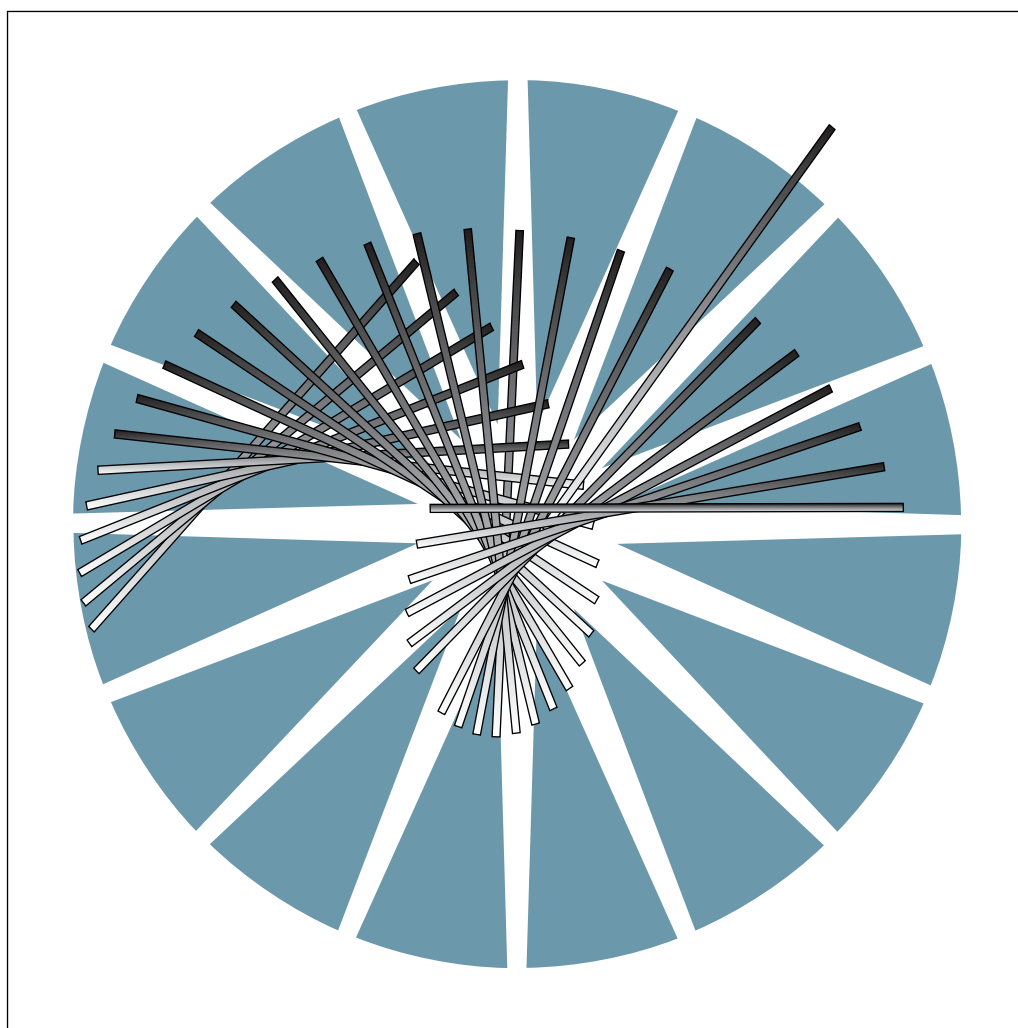

Hardware Maintenance Reference



IBM 3745 Communication Controller
Models 130, 150, 160, 170 and 17A



Hardware Maintenance Reference

Note!

Before using this information and the product it supports, be sure to read the general information under "Notices" on page vii.

Fifth Edition (January 1994)

The information contained in this manual is subject to change from time to time. Any such changes will be reported in subsequent revisions. Changes have been made throughout this edition, and this manual should be read in its entirety.

Order publications through your IBM representative or the IBM branch office serving your locality. Publications are not stocked at the address given below.

A form for readers' comments appears at the back of this publication. If the form has been removed, address your comments to:

IBM France
Centre d'Etudes et Recherches
Service 0797 BP 79
06610 La Gaude
France

- FAX: (33) 93.24.77.97
- EMAIL: FRIBMQF5 at IBMAIL
- IBM Internal Use: LGERCF at LGEPROFS

When you send information to IBM, you grant IBM a non-exclusive right to use or distribute the information in any way it believes appropriate without incurring any obligation to you.

© **Copyright International Business Machines Corporation 1989, 1994. All rights reserved.**

Note to U.S. Government Users — Documentation related to restricted rights — Use, duplication or disclosure is subject to restrictions set forth in GSA ADP Schedule Contract with IBM Corp.

Contents

Notices	vii
Electronic Emission Notices	vii
Trademarks and Service Marks	ix
Product Safety Information	xi
General Safety	xi
Safety Notices	xi
Service Inspection Procedures	xi
About This Book	xiii
Who Should Use This Book	xiii
Service Personnel Definitions	xiii
How to Use the Maintenance Library	xiii
Where to Find More Information	xiv
Summary of Changes	xv
Chapter 1. General Information	1-1
3745 in a Network	1-2
Identification and Capacity	1-5
Controller Structure	1-7
Programming Support and Network Management	1-20
Maintenance	1-24
Chapter 2. Central Control Unit (CCU)	2-1
General Description	2-4
Functional Description	2-5
CCU Environment	2-12
Main Storage	2-13
CCU-to-Storage Interconnection	2-17
CCU to and from Adapters	2-20
CCU to and from MOSS	2-43
CCU Diagnostics	2-43
Performance Test Points	2-50
Chapter 3. Buses	3-1
Generalities	3-4
Bus Propagation Cards (BPC1/BPC2)	3-29
3746-900/3745 Attachment	3-30
Adapter Addressing	3-31
Adapter Bypass Mechanism	3-48
IOC Bus Scoping Routine	3-53
Chapter 4. Transmission Subsystem (TSS)	4-1
Low-Speed Scanner (LSS)	4-7
LIC Board	4-7
Serial Link (SL)	4-13
Communication Scanner Processor (CSP)	4-13
Front-End Scanner (FES)	4-23
Front-End Scanner Adapter (FESA)	4-27

Serial Link (SL)	4-34
Double Multiplexer Card (DMUX)	4-35
Single Multiplexer Card (SMUXA/B)	4-39
LIC Types 1 to 4 Cards	4-43
LIC Types 5 and 6 DTE Function	4-54
LIC Type 5 DCE Function	4-57
LIC Type 6 DSU/CSU Function	4-80
Problem Determination Aid for LIC Types 1 to 4	4-92
Problem Determination Aid for LIC Type 5 and LIC Type 6	4-95
TSS Interface Cables	4-100
Chapter 5. High Performance Transmission Subsystem (HPTSS)	5-1
Introduction	5-5
Internal Interconnections	5-10
Communication Scanner Processor (CSP)	5-11
Front-End Scanner High-Speed (FESH)	5-12
Transmit Operation	5-15
Receive Operation	5-17
Modem Interface Management	5-19
Error Detection and Reporting	5-23
Miscellaneous Status Fields	5-31
Problem Determination Aid	5-37
Communication Interfaces	5-40
Chapter 6. The Token-Ring Subsystem	6-1
Token-Ring Network	6-4
The Token-Ring Adapter in the 3745	6-10
Token-Ring Interface Coupler (TIC) Card	6-12
Token-Ring Multiplexor (TRM) Card	6-15
TRA Resets	6-19
Error Detection and Reporting	6-20
Problem Determination Aid	6-27
Chapter 7. Channel Adapter (CA)	7-1
Introduction	7-4
CA Operating Environment	7-8
Overall Operation	7-9
Autoselection	7-12
Cycle Steal	7-14
CA/MOSS Connection	7-15
Interrupt Requests	7-16
Two-Processor Switch (TPS)	7-17
Channel Stop	7-21
Interface Disconnect	7-21
I/O Error Alert	7-21
Testing and Checking Hardware	7-22
CA Initialization	7-24
Chapter 8. Maintenance and Operator Subsystem (MOSS)	8-1
Introduction	8-4
MOSS Reset	8-5
MOSS Functions	8-8
MOSS States	8-9
Branch Trace	8-11

Mailbox Description	8-13
LSSD Operation	8-17
MOSS/Disk Drive Interaction	8-19
MOSS/Operator Console Connections	8-20
Chapter 9. Control Panel, Operator Consoles, Disk/Diskette Drives	9-1
Control Panel	9-2
Operator Consoles for Models 1x0	9-6
Operator Consoles and Service Processor for Model 17A	9-8
Disk/Diskette Drive	9-9
Chapter 10. Power System	10-1
Introduction	10-4
AC Voltages Input	10-5
Power Control Subsystem	10-15
Power Mode of Operation	10-20
Power ON/OFF Sequence	10-22
Power ON Reset (POR)	10-29
3746 Model 900 Power Connection and Control	10-34
Chapter 11. Error Logging	11-1
Introduction	11-4
BER Generalities	11-6
BERs Which Are Not Machine Errors	11-11
Specific Mechanisms	11-12
AutoMaint	11-16
BER Recovery Procedures	11-24
Unresolved Interrupts	11-25
MOSS Error Logging	11-29
MOSS BERs Used With the IPL Application	11-33
Diagnostics BER Type 03	11-123
Power BER Type 04	11-125
NCP ESS BER Type 08	11-133
NCP 3746 Model 900 BER Type 9	11-145
NCP CA BER Type 10	11-164
NCP TSS/HPTSS BER Type 11	11-179
NCP/PEP BER, Type 12	11-191
NCP CCU BER Type 13	11-194
NCP IOC BER Type 14	11-198
NCP TRSS BER Type 15	11-201
Chapter 12. Ethernet Subsystem (ESS)	12-1
Introduction	12-5
Frame Types Supported	12-9
ELA Microcode Description	12-11
Internal Interconnections	12-13
Communication Scanner Processor (CSP)	12-14
Ethernet LAN Coupler Card (EAC)	12-15
ELA Command Description	12-18
Parameter/Status Area Layout	12-29
Error Detection and Reporting	12-36
Problem Determination Aid	12-45
List of Abbreviations	X-1

Glossary	X-7
Bibliography	X-9
Customer Documentation for the 3745 (Models 130, 150, 160, 170, and 17A) and 3746 (Model 900)	X-9
Service Documentation for the 3745 (Models 130, 150, 160, 170, and 17A) and 3746 (Model 900)	X-13
Index	X-17

Notices

References in this publication to IBM products, programs or services do not imply that IBM intends to make these available in all countries in which IBM operates. Any reference to an IBM product, program, or service is not intended to state or imply that only IBM's product, program, or service may be used. Any functionally equivalent product, program, or service that does not infringe any of IBM's intellectual property rights may be used instead of the IBM product, program, or service. Evaluation and verification of operation in conjunction with other products, except those expressly designated by IBM, is the user's responsibility.

IBM may have patents or pending patent applications covering subject matter in this document. The furnishing of this document does not give you any license to these patents. You can send license inquiries, in writing, to the IBM Director of Commercial Relations, IBM Corporation, Purchase, NY 10577, U.S.A.

Electronic Emission Notices

Federal Communications Commission (FCC) Statement

Note: This equipment has been tested and found to comply with the limits for a Class A digital device, pursuant to Part 15 of the FCC Rules. These limits are designed to provide reasonable protection against harmful interference when the equipment is operated in a commercial environment. This equipment generates, uses, and can radiate radio frequency energy and, if not installed and used in accordance with the instruction manual, may cause harmful interference to radio communications. Operation of this equipment in a residential area is likely to cause harmful interference, in which case the user will be required to correct the interference at his own expense.

Properly shielded and grounded cables and connectors must be used in order to meet FCC emission limits. IBM is not responsible for any radio or television interference caused by using other than recommended cables and connectors or by unauthorized changes or modifications to this equipment. Unauthorized changes or modifications could void the user's authority to operate the equipment.

This device complies with Part 15 of the FCC Rules. Operation is subject to the following two conditions: (1) this device may not cause harmful interference, and (2) this device must accept any interference received, including interference that may cause undesired operation.

Industry Canada Compliance Statement

This Class A digital apparatus meets all requirements of the Canadian Interference-Causing Equipment Regulations.

Avis de conformité aux normes d'Industrie Canada

Cet appareil numérique de la classe A respecte toutes les exigences du Règlement sur le matériel brouilleur du Canada.

Japanese Voluntary Control Council for Interference (VCCI) Statement

This equipment is Class 1 Equipment (information equipment to be used in commercial and industrial districts) which is in conformance with the standard set by Voluntary Control for Interference by Data Processing Equipment and Electronic Office Machines (VCCI) with an aim to prevent radio interference in commercial and industrial districts. This equipment could cause interference to radio and television receivers when used in and around residential districts. Please handle the equipment properly according to the instruction manual.

情報処理装置等電波障害自主規制協議会
(VCCI)表示

電波障害自主規制届出装置の記述

この装置は、第一種情報装置（商工業地域において使用されるべき情報装置）で商工業地域での電波障害防止を目的とした情報処理装置等電波障害自主規制協議会（VCCI）基準に適合しております。従って、住宅地域またはその隣接した地域で使用すると、ラジオ、テレビジョン受信機等に受信障害を与えることがあります。

関連マニュアルに従って正しい取り扱いをしてください。

Korean Communications Statement

Please note that this device has been approved for business use with regard to electromagnetic wave interference. If you find this is not suitable for your use, you may exchange it for one designated for non-business purposes.

대한민국 통신문

이 기기는 업무용으로 전자파장애검정을 받은 기기이오니 판매자 또는 사용자는 이 점을 주의하시기 바라며, 만약 잘못 구입하였을 때에는 구입한 곳에서 비업무용으로 교환하시기 바랍니다.

Trademarks and Service Marks

The following terms, denoted by an asterisk (*), used in this publication, are trademarks or service marks of IBM Corporation in the United States or other countries:

ESCON
MVS
PS/2
VTAM

IBM
NetView
RETAIN

LPDA
OS/2
VES

Product Safety Information

General Safety

This product meets safety IBM standards.

For general safety information, see:

- *Telecommunication Products Safety Handbook*, GA33-0126

Safety Notices

See *Safety Notices* located at the beginning of the *Maintenance Information Procedures* manual.

Service Inspection Procedures

The Service Inspection Procedures help service personnel check whether the 3745 conforms to IBM* safety criteria. They have to be used each time the 3745 safety is suspected.

The *Service Inspection Procedures* section is located at the beginning of the *3745 Maintenance Information Procedures (MIP)* manual, SY33-2070.

The 3745 areas and functions checked through service inspection procedures are:

1. External covers
2. Safety labels
3. Safety covers and shields
4. Grounding
5. Circuit breaker and protector rating
6. Input power voltage
7. Power-ON indicator
8. Emergency power OFF.

About This Book

This manual provides:

1. Introductory and how-to-fix information
2. Information for maintaining CSAs (Common Sub-assemblies)
3. Description of IBM 3745 Communication Controller functional units.

The console(s) and operator panel procedures are not provided in this manual, but are in the:

- *3745 Advanced Operations Guide*, SA33-0097, and *3745 Service Functions*, SY33-2069, for the maintenance functions used by service personnel.
- *3745 Basic Operations Guide*, SA33-0098 for 3745 Models 130 to 170 or SA33-0177 for 3745 Model 17A, for the control panel functions.

Who Should Use This Book

This manual is intended for the product support-trained CE (PST CE) to service the IBM 3745 Communication Controller whenever the product-trained CE (PT CE) cannot repair the machine using the *Maintenance Information Procedures* manual.

The person using this *Hardware Maintenance Reference* (HMR) manual should:

- Have an understanding of the telecommunications environment.
- Be trained to service the 3745 Communication Controller.
- Be familiar with the data circuit terminating equipment (modems, autocal units, and so on) and the terminals that attach to 3745s.
- Be familiar with the host channel to which the 3745 can be attached.

Service Personnel Definitions

See *Maintenance Information Procedures* (MIP) SY33-2070, manual.

How to Use the Maintenance Library

Maintenance on the 3745 is performed only when a failure or suspected failure occurs in the machine. The customer is first expected to perform problem determination to see if a 3745 problem exists. He uses the *Problem Determination Guide* and a host or 3745 console to perform the requested procedures. The problem determination guide generally produces a reference code that the customer should provide to the Hardware Central Service (HCS)

If the HCS is contacted, they will confirm that the initial problem determination has been done correctly, and determine if a hardware failure is indicated. Where hardware replacement is required, the HCS will determine which FRU(s) should be replaced, and dispatch a CE with the information needed to identify and replace them. When replacement has been completed, the CE will test the machine as directed by the *MIP* and *Service Functions* manuals, to verify the repair.

At this point, the *Maintenance Information Procedures* portion of the 3745 Maintenance Library has been exhausted. If additional problem analysis is required, the CE should contact the HCS for assistance, since the problem may require special tools or techniques that are described in the *Hardware Maintenance Reference* and *Service Functions* manuals, and are applied by a Product Support-Trained CE.

Where to Find More Information

See "Bibliography" page X-9.

Summary of Changes

This revised edition gives information concerning the 3745 Model 17A and on the 3746 Model 900 connection.

This edition also corrects minor errors or omissions without the addition of revision bars.

Chapter 1. General Information

3745 in a Network	1-2
3745 Models 130, 150, 160, and 170 Data Flow	1-3
3745 Model 17A Data Flow	1-4
Identification and Capacity	1-5
3745 Model 130	1-5
3745 Model 150	1-5
3745 Model 160	1-5
3745 Model 170	1-5
3745 Model 17A	1-6
Basic Configuration (Minimum Configuration)	1-6
Controller Structure	1-7
Control Subsystem (CSS)	1-7
Communication Subsystem	1-8
Low-/Medium-Speed Transmission Subsystem (TSS)	1-9
High-Performance Transmission Subsystem (HPTSS)	1-12
Ethernet Subsystem (ESS)	1-13
Token-Ring Subsystem (TRSS)	1-14
Maintenance and Operator Subsystem (MOSS)	1-15
Programming Support and Network Management	1-20
Host-Resident Programs	1-20
Controller-Resident Programs	1-22
Generating and Loading the Control Program	1-23
Maintenance	1-24
Preventive Maintenance	1-24
Maintenance Aids	1-24

3745 in a Network

The 3745 can be:

- 1 Channel-Attached** (via channel adapter) to one or more hosts.
- 2 Link-Attached** (via telecommunication facilities) to a host through another IBM Communication Controller (allowing the 3745 to be used as a remote concentrator).

Then, the 3745 allows simultaneous connection to:

- a. Other IBM communication controllers, via high-speed lines (such as T1 or CEPT) and their associated DCEs.
- b. Other IBM communication controllers, via medium- or high-speed lines and their associated DCEs.
- c. Local clusters and terminals, directly attached without DCE.
- d. Remote clusters and terminals, via stand-alone DCEs and telecommunication facilities (switched or non-switched).
- e. Remote communication controllers/clusters/terminals via X.25 public data networks.
- f. Remote communication controllers/clusters/terminals via integrated DCEs and 4-wire nonswitched telecommunication facilities or DDS network in the US.
- g. Communication controllers/clusters/terminals on IBM token-ring local area networks or Ethernet-type local area networks.

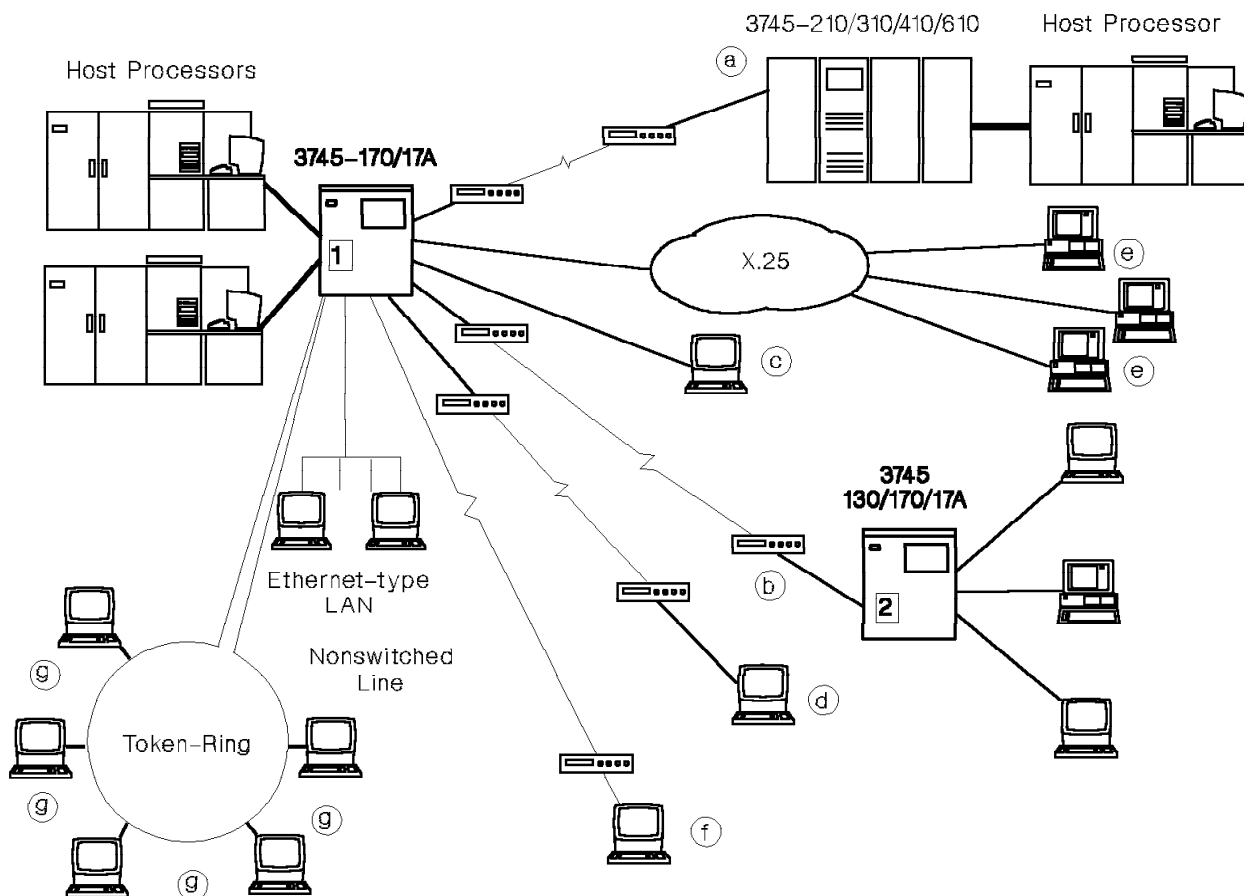
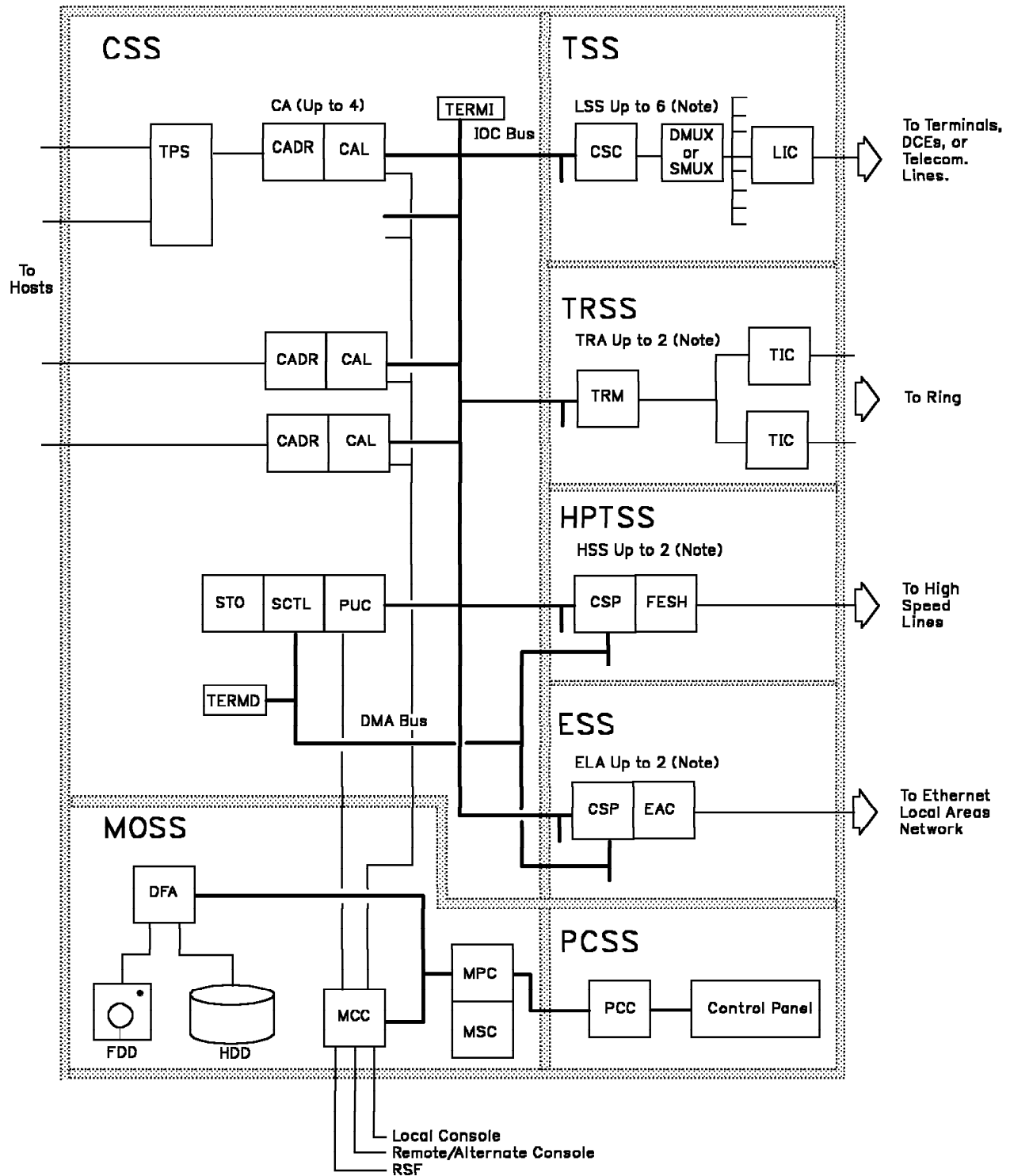

Figure 1-1. 3745 in a Network

3745 Models 130, 150, 160, and 170 Data Flow



(Note) The number of LSS+HSS+ELA does not exceed 6

3745 Model 17A Data Flow

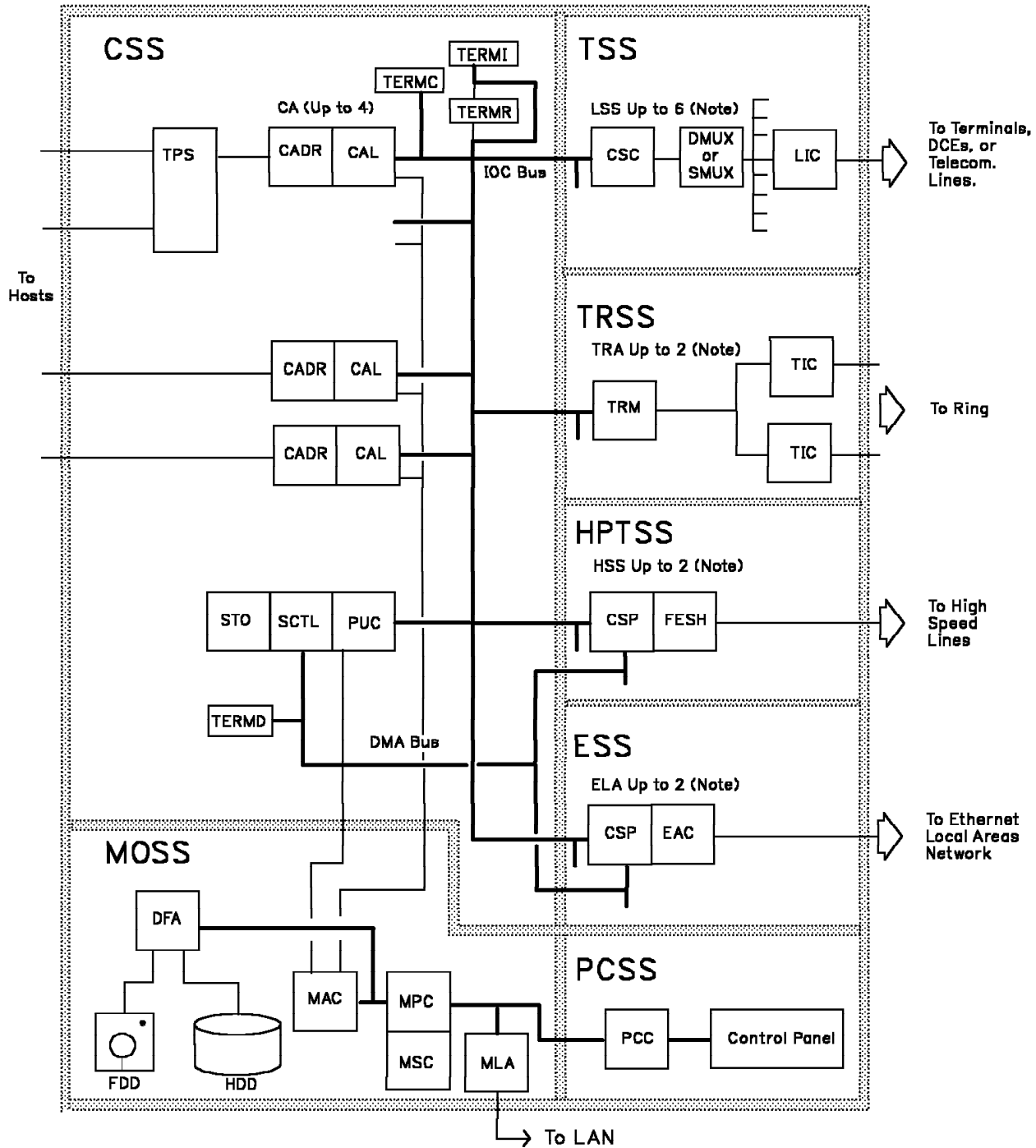

(Note) The number of LSS+HSS+ELA does not exceed 6

Figure 1-2. 3745 Model 17A Data Flow. For model 17A, DMA and IOC buses are connected to the CBC in the 3746-900. This MLA card links the MOSS to the Service Processor through a LAN.

Identification and Capacity

Note: All the following connection capabilities might not be present at the same time as some items are mutually exclusive (see *3745 Configuration Program*, GA33-0093).

3745 Model 130

- 4 CAs
- 0 low-speed scanner (LSS)
- 2 High-speed scanners (HSS)
- 2 Ethernet LAN adapter (ELA)
- 2 Token-ring adapters (TRA).

3745 Model 150

- 0 CA
- 1 low-speed scanner (LSS)
- 1 High-speed scanner (HSS)
- 1 Ethernet LAN adapter (ELA)
- 1 Token-ring adapter (TRA)
- 32 Low-/medium-speed lines
- 16 integrated DCEs 14.4 kbps
- 3 integrated DCEs 56 kbps.

3745 Model 160

- 0 CA
- 2 low-speed scanners (LSS)
- 2 High-speed scanners (HSS)
- 2 Ethernet LAN adapters (ELA)
- 1 Token-ring adapter (TRA)
- 32 Low-/medium-speed lines

3745 Model 170

- 4 CAs
- 6 low-speed scanners (LSS)
- 1 Token-ring adapter (TRA)
- 2 High-speed scanners (HSS)
- 2 Ethernet LAN adapter (ELA)
- 96 Low-/medium-speed lines
- 32 Integrated DCEs 14.4 kbps
- 8 Integrated DCEs 56 kbps.

3745 Model 17A

The 3745 Model 17A has the same capacity than the 3745 Model 170 with the possibility of connection of a 3746 Model 900.

Basic Configuration (Minimum Configuration)

Feature	Model	Quantity	Location
4 MB storage	ALL	1	01G-A1 X2
LSS adapter	150	1	01G-A1 Q2
LIC Unit (LIB1 or LIB2)	150	1	01M-A2
LSS adapter (Note 1) with a LIC unit (LIB1)	160	1 1	01G-A1 Q2 01M-A2
HSS adapter (Note 1)	160	1	01G-A1 T2 and U2
ESS adapter (Note 1)	160	1	01G-A1 T2 and U2
TRSS adapter (Note 1)	160	1	01G-A1 J2, K2, and L2

Notes:

1. These adapters are mutually exclusive on Model 160.

Controller Structure

The 3745 consists of four functional areas:

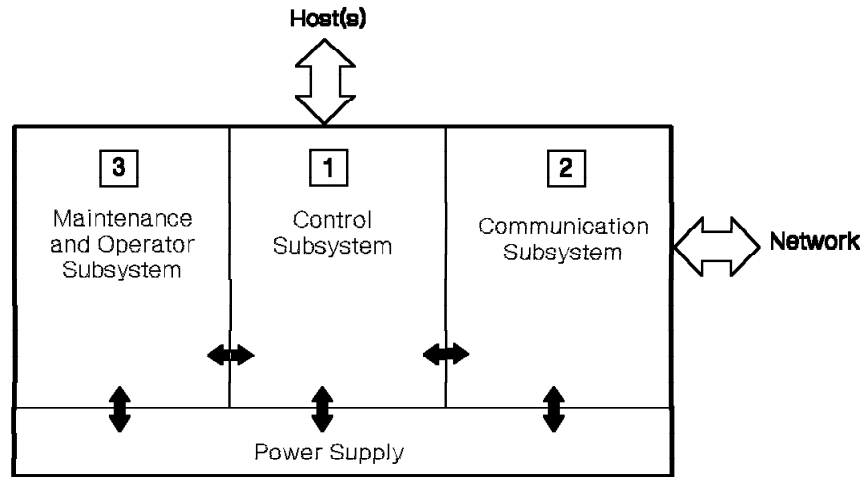

Control Subsystem (CSS)

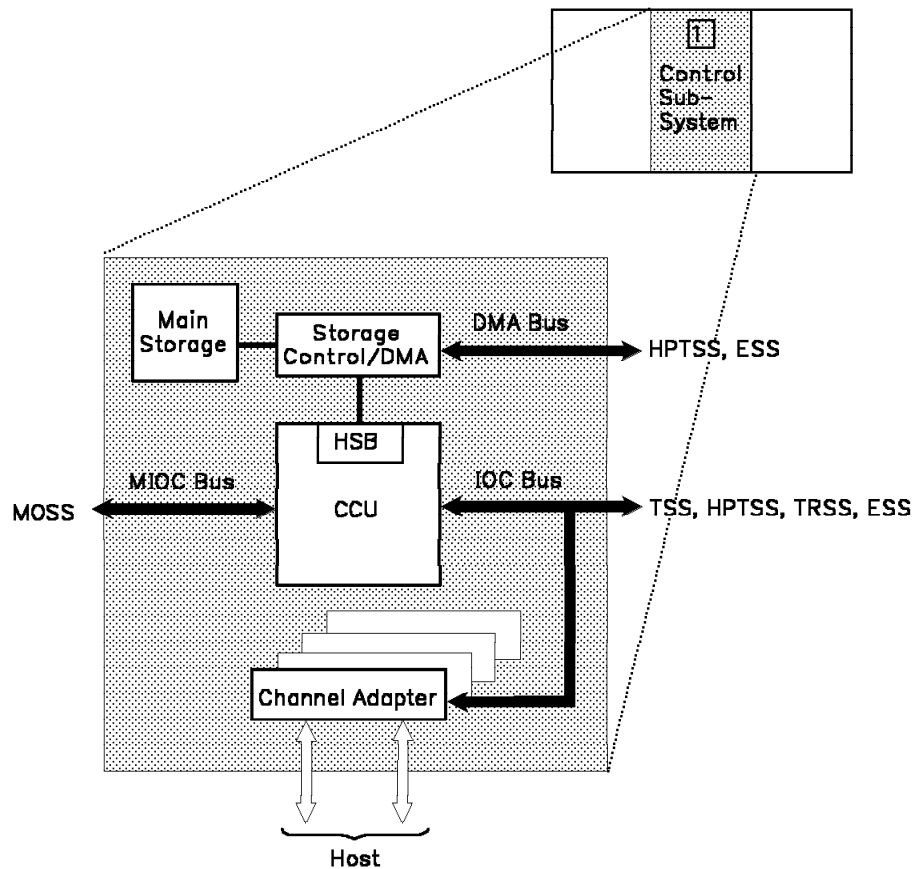

The control subsystem contains:

- The central control unit (CCU), with its associated high-speed buffer (HSB).
- The main storage.
- The storage control, equipped with a direct memory access (DMA).

- The channel adapters, eventually associated with two-processor switches (TPS).
- Two types of channel adapter are available:
- Channel adapter type 6: Channel adapter data streaming (CADS)
 - Channel adapter type 7: Buffer chaining channel adapter (BCCA).
- The input/output control bus (IOC bus).
 - The DMA bus.
 - The MOSS input/output control bus (MIOC bus).

Communication Subsystem

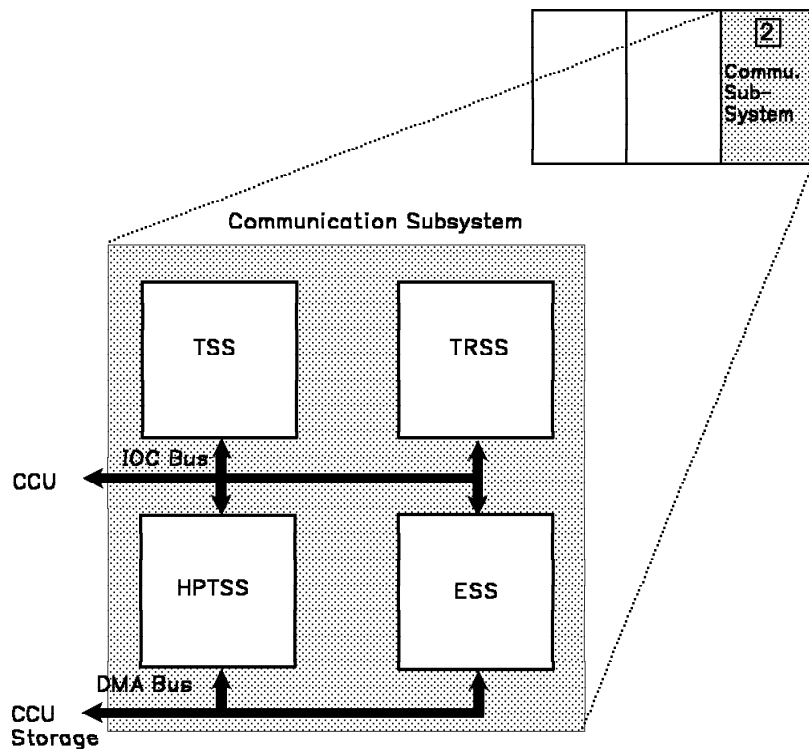

Four types of line connection are used to connect data communication lines:

- The low-/medium-speed transmission subsystem (TSS).
- The high-performance transmission subsystem (HPTSS).
- The Ethernet subsystem (ESS).
- The token-ring subsystem (TRSS).

Low-/Medium-Speed Transmission Subsystem (TSS)

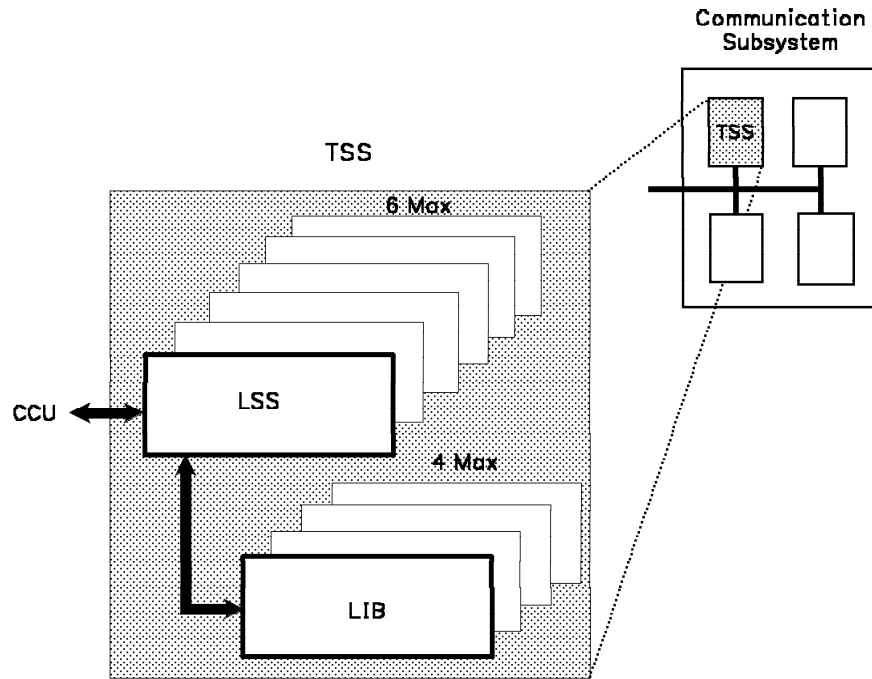

The TSS consists:

- Up to six low-speed scanners (LSS)
- Up to four LIC boards (LIBs).

Low-Speed Scanner

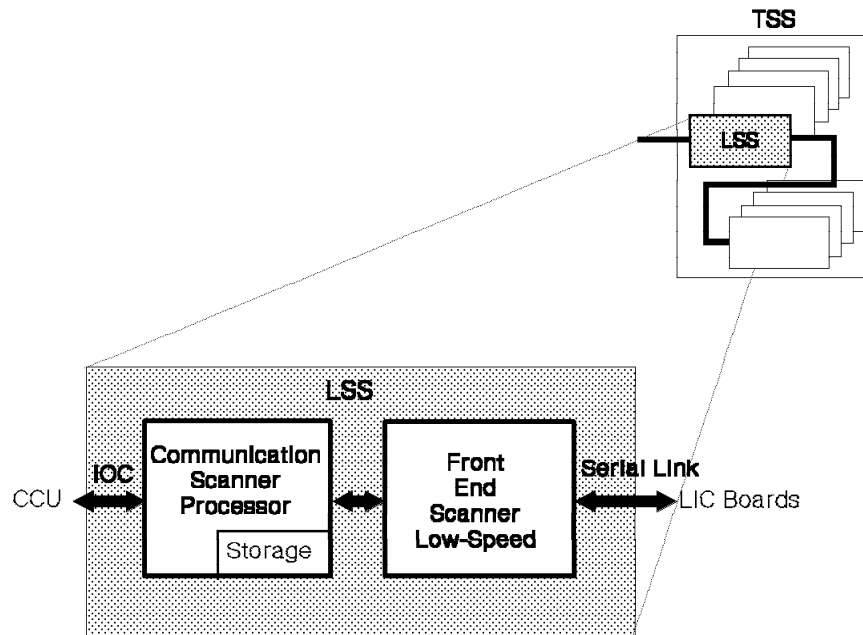

A low-speed scanner consists of one card housing a communication scanner processor (CSP) associated to a front-end scanner low-speed (FESL).

LIC Board (LIB)

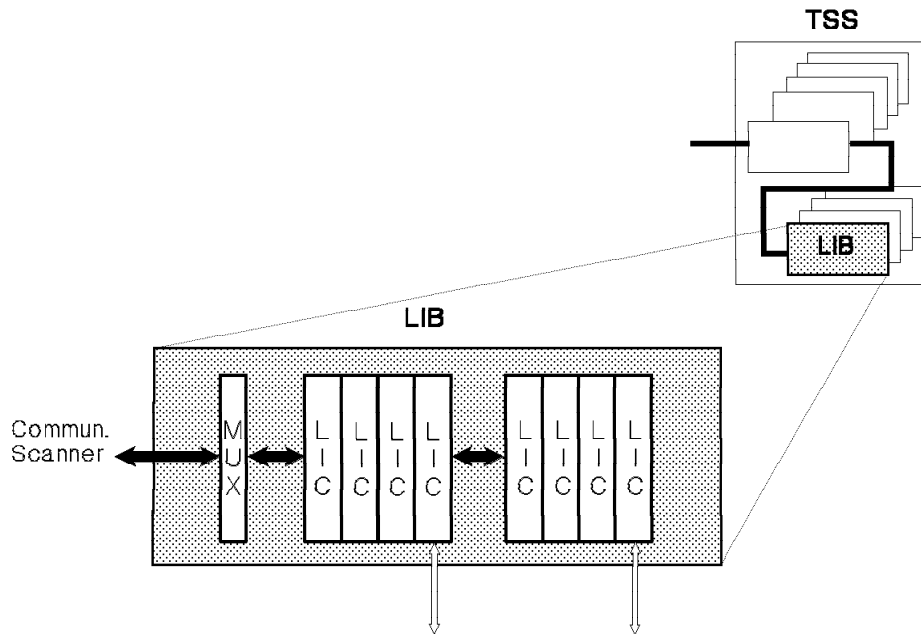

There are up to four LIC boards (LIB).

Each LIB houses:

- One multiplexer (MUX) and
- Up to eight line interface couplers (LICs).

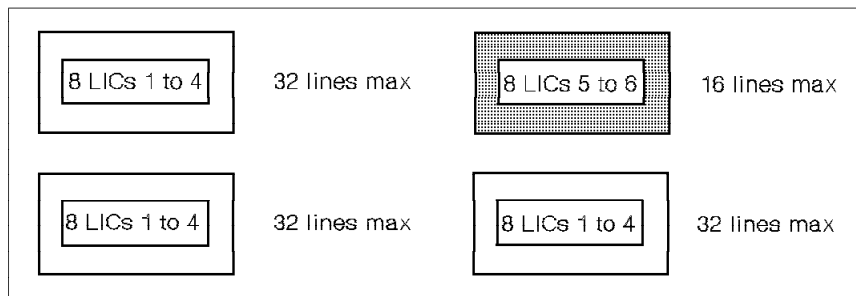

or

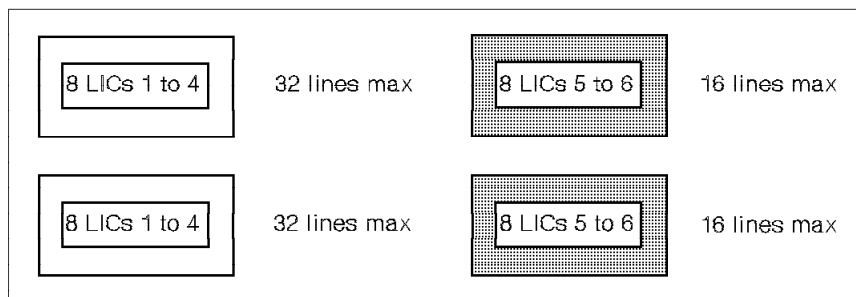

Three types of LIB can be installed:

- LIC board type 1 (LIB1) on 3745 models 150, 160, and 170. LIB1 houses up to 8 LICs type 1-4.
- LIC board type 2 (LIB2) on 3745 models 150 and 170. LIB2 houses up to 8 LICs type 5-6.
- LIC board type 3 (LIB3) on 3745 model 150. LIB3 houses up to 4 LICs type 1-4.

Line Interface Couplers (LICs)

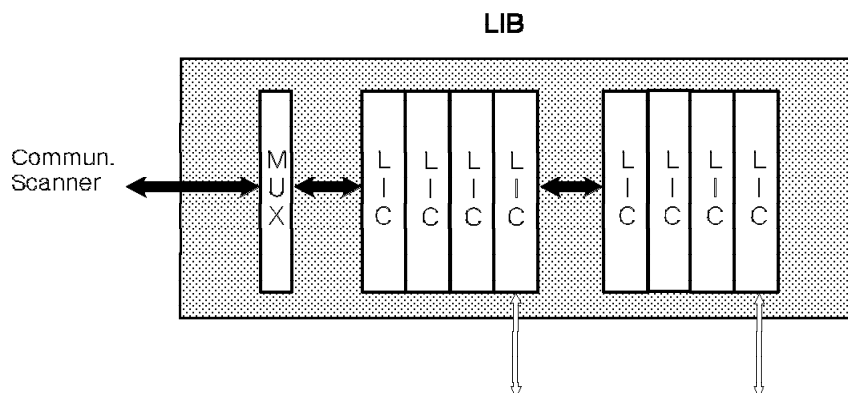

There are six types of LIC, namely:

- **LIC1, LIC3, LIC4A** and **LIC4B** for attaching to:
 - Local direct-attached terminals (no DCEs)
 - Remote terminals via standalone DCEs and telecommunication facilities.

An internal clock function (ICF) is available on these LICs to provide clocking signals to non-clocked DTEs or DCEs.

- **LIC5** and **LIC6**, both housing integrated DCEs, providing direct access to the telecommunication facilities for attaching to remote terminals.

High-Performance Transmission Subsystem (HPTSS)

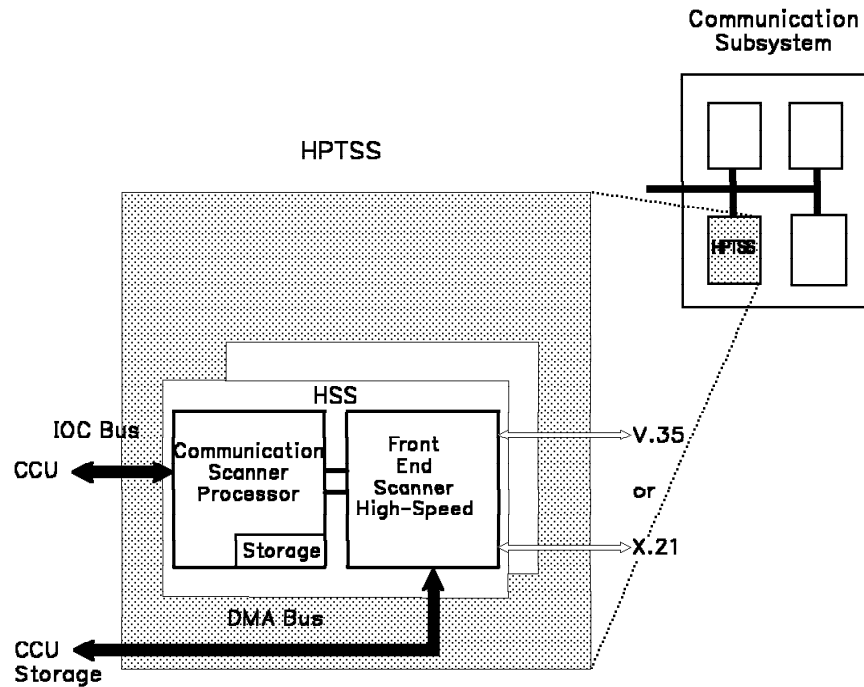

The HPTSS consists of up to two high-speed scanners (HSS).

Each HSS consists of a communication scanner processor (CSP) card, associated with a front-end scanner high-speed (FESH) card.

Ethernet Subsystem (ESS)

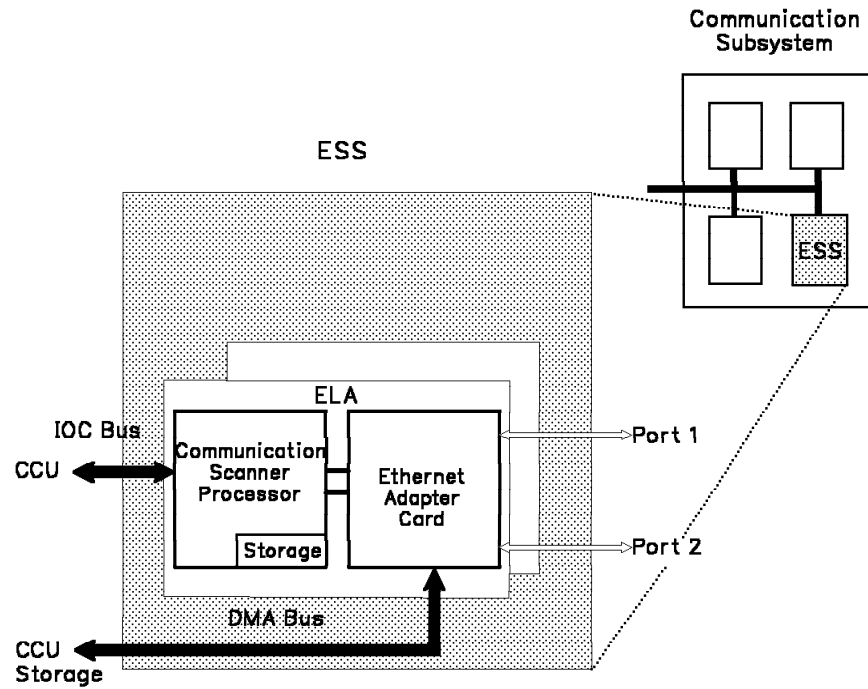

The ESS consists of up to two Ethernet LAN adapters (ELA).

Each ELA consists of a communication scanner processor (CSP) card, associated with an Ethernet adapter card (EAC).

Token-Ring Subsystem (TRSS)

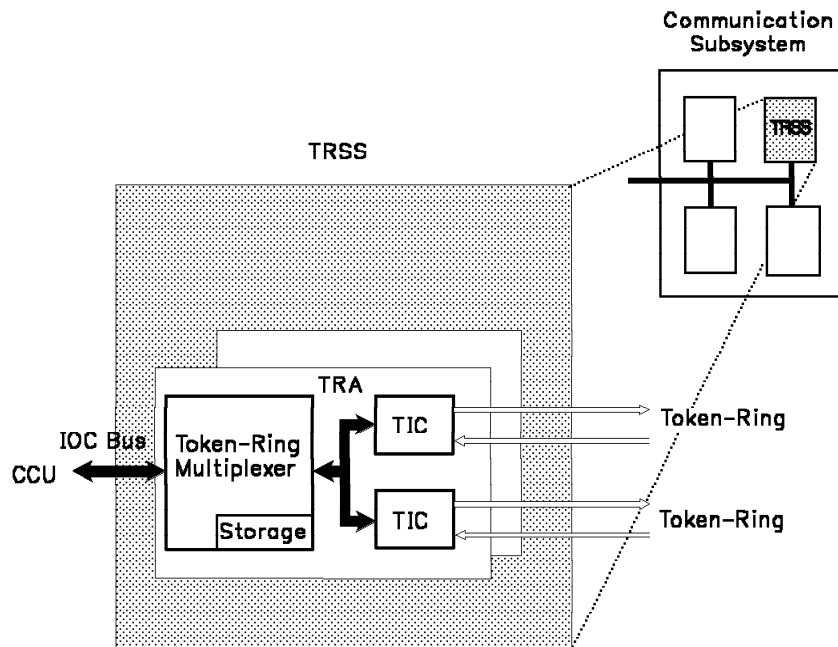

The TRSS consists of one token-ring multiplexer (TRM) driving two token-ring interface couplers (TICs) providing access to two IBM token-rings operating at 4 or 16 Mbps.

Maintenance and Operator Subsystem (MOSS)

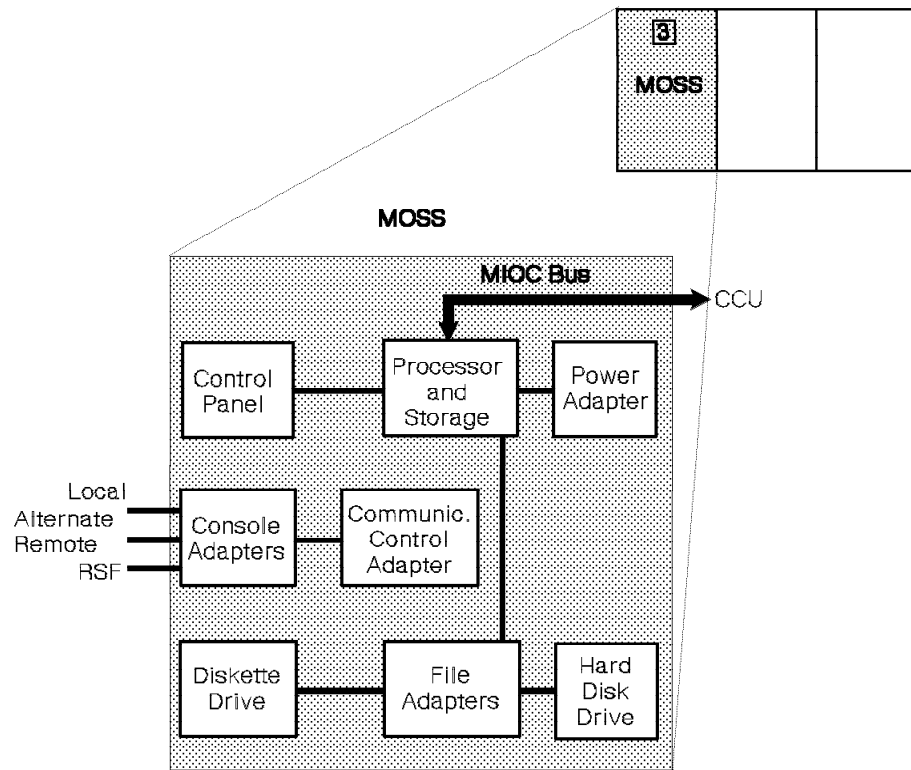

The MOSS provides:

- Powerful procedures for the 3745 initialization and IPL functions.
- Host-independent product maintenance and rapid isolation and repair of failures within the controller.
- Easy problem determination procedures for the operator.

The MOSS also provides:

- Controller initialization, IML and IPL control
- Automatic IPL and dump operations
- Operating mode management
- Line configuration management
- Controller supervision
- Controller concurrent diagnostic
- Online event recording and error notification including for the integrated DCEs
- Problem determination (error in the network including the controller)
- Failure isolation and repair (error in the controller)
- Remote support facility link management.

The MOSS continuously monitors the status of the communication controller. Abnormal conditions are analyzed and reported via alarms to the 3745 console(s) and alerts to the network control console.

Among the components of the communication controller, multiple adapters allow the MOSS to monitor the status of the CCU, control DMA, and IOC bus, and to enable and disable channel adapters.

A power control adapter with a dedicated microprocessor monitors 3745 power.

A file adapter provides MOSS storage control. A 72MB hard disk, in addition to a 1.2MB diskette, provides extensive capacity for file and data storage.

The MOSS interfaces to the control panel indicators and switches. These provide an alternative method for controlling the primary power subsystem, activating MOSS functions, and for operator notification.

On 3745 Model 1x0 a console adapter allows 3745 to be controlled from a local console located within 7 m (23 ft), or an alternate console located within 120 m (400 ft), or a remote console connected via a 1200 bps DCE to the controller. Only one console may be active at a time. If the remote support facility is used, it allows communication between the MOSS and the IBM RETAIN system, providing remote service facility (RSF). The RETAIN terminal can be used as an operator console as well as for transferring microcode patches to the MOSS if required. Refer to "3745 Models 130, 150, 160, and 170 Operator Consoles" on page 1-17.

The 3745 Model 17A uses a LAN attached console (service processor). Refer to "3745 Model 17A Console Summary" on page 1-18.

3746 Model 900 Connectivity Switch

The 3746-900 is a frame connected to the 3745 Model 17A.

The 3746-900 provides new adapters to the 3745 to attach:

- Enterprise Systems Connection (ESCON*) channel
- TIC3 couplers (4 or 16 MBps).
- LIC type 11 (up to 256 kbps)
- LIC type 12 (up to 2 Mbps)

A new MOSS hardware and microcode for connection to the service processor, via the LAN, is installed on the 3745 Model 17A. The service processor (PS/2 based) is used as 3745 MOSS console.

For more details on the 3746-900, refer to the soft copy manual: *3746 Model 900 Hardware Maintenance Reference*.

3745 Models 130, 150, 160, and 170 Operator Consoles

An operator console is required for:

- Installation
- Operation
- Maintenance.

The 3745 provides attachment for three different types of consoles:

- A **local** console, which is mandatory, and
- A **remote** or an **alternate** console.

It also provides attachment for the **remote support facility (RSF)**. The consoles and RSF are connected to the MOSS via a common communication adapter.

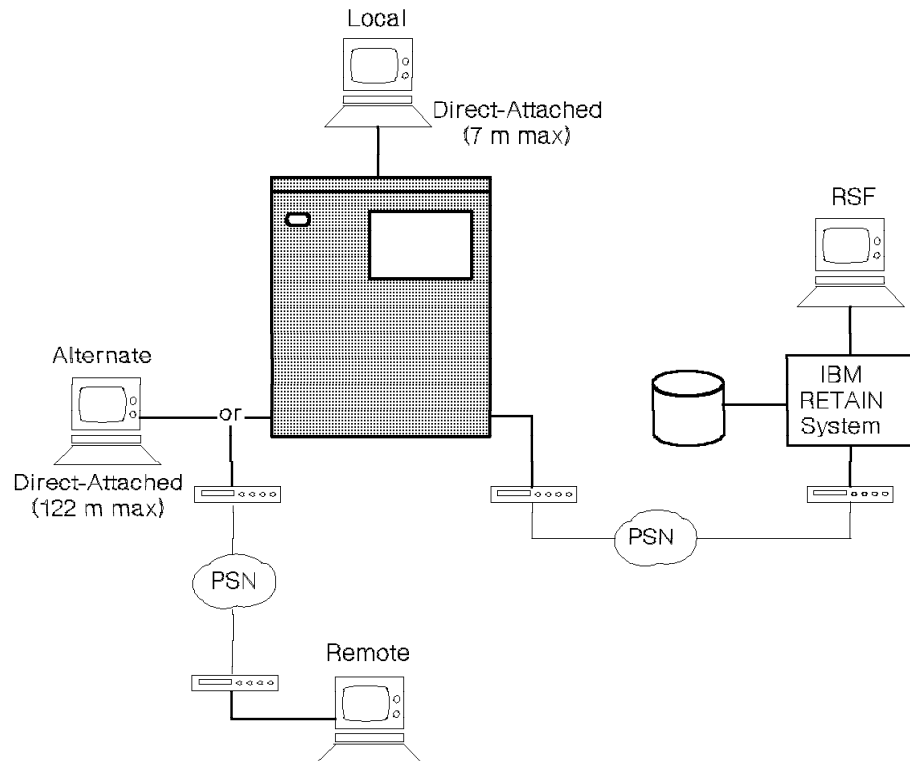

Only one console can be active at a time.

Three types of password enable access to the MOSS from a local, remote or alternate console, and for remote IBM maintenance (via RSF).

3745 Model 17A Console Summary

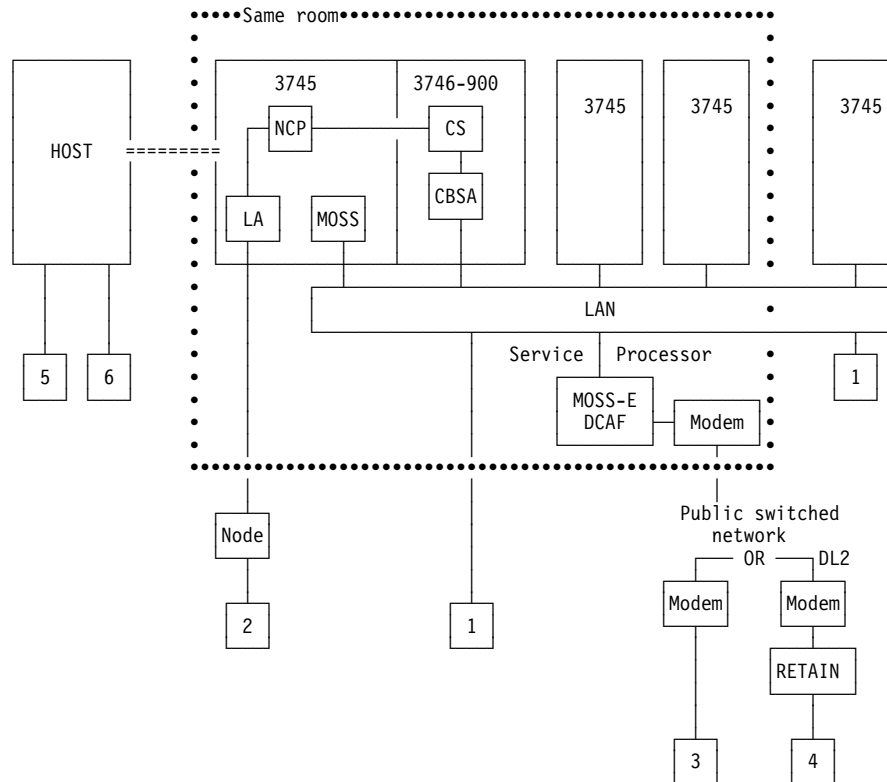

1. LAN attached console (OS/2 with DCAF)
2. Remote console via user network (PS/2 with DCAF). See Note.
3. RSF console via PSN (OS/2 with DCAF)
4. RETAIN console
5. Access method console
6. NetView console.

Note: If no 3746-900 is installed the service processor must be connected to the 3745 through a TIC2 for the use of the remote console.

Power ON/OFF

The 3745 can be:

1. Powered ON and OFF by a channel-attached host.
2. Powered ON and OFF locally by the operator.
3. Powered ON by the operator and OFF by a remote SNA command.
4. Powered ON through the scheduled power ON MOSS function.
5. Re-powered ON automatically by the auto-restart function after a power outage.
6. Re-powered ON automatically by a retry function after a power supply or fan problem.

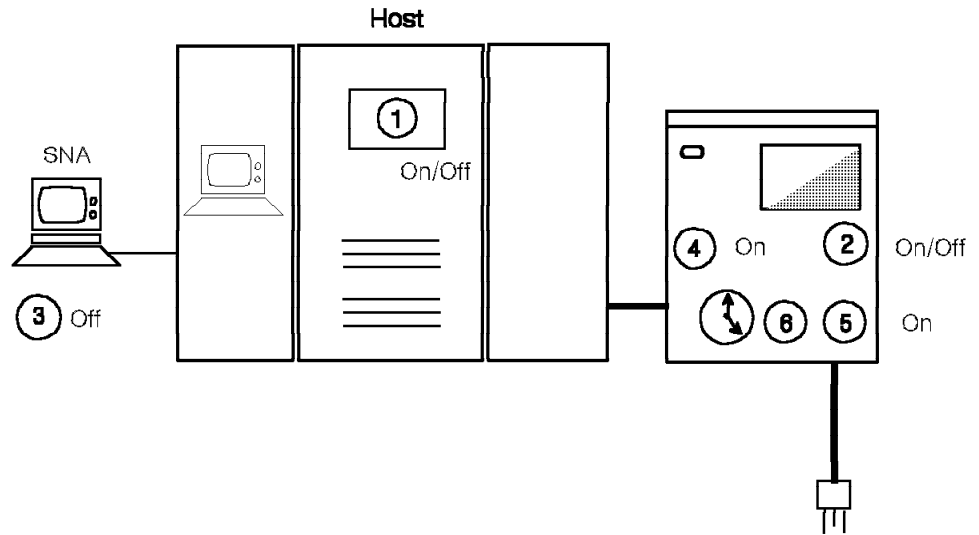

Programming Support and Network Management

The 3745 operates under the control of IBM licensed programs:

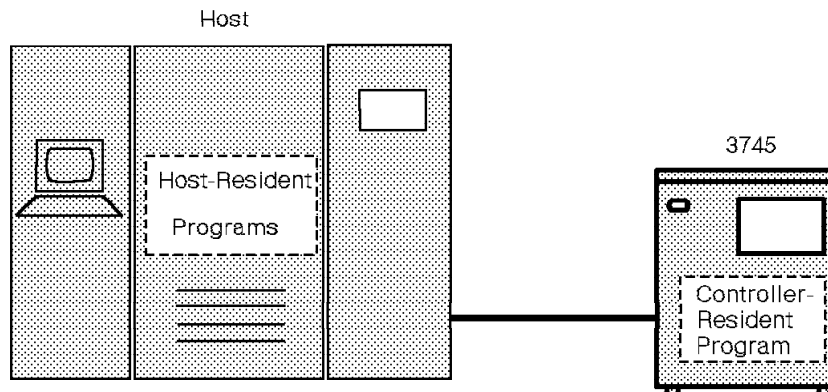

Host-Resident Programs

Operating Systems

- MVS*/370
- MVS/XA
- VM/SP
- VM/SP HPO
- VM/XA
- VSE*/AF
- VSE/SP.

Access Methods

Normal Mode:

- Virtual Telecommunications Access Method (VTAM*).

Emulation Mode:

- Basic Telecommunications Access Method (BTAM)
- BTAM Extended Support (BTAM-ES)
- Remote Terminal Access Method (RTAM).

System Support Programs

- Advanced Communications Function for System Support Programs (SSP) in an MVS environment,
- Advanced Communications Function for System Support Programs in MVS, VM, and VSE environments.

SSP is used to generate the 3745 control program.

In addition, SSP provides utilities for loading, dumping, and tracing the 3745 control program.

It also supports:

- Dump transfer of the 3745 storage to the host.
- Dump printing at the host.
- 3745 disk file transfer to the host.

Network Management

The 3745 network management is supported by the NetView* program. By monitoring and managing the controller and its resources, and by diagnosing problems, this program contributes to the optimization of the 3745.

It integrates functions of several network management products and VTAM functions, for example:

- A command facility, which lets the user control, record, and automate various operator tasks. It can be used as an operator's interface to VTAM in a data communication network.
- A session monitor, which enables the user to examine, from a central control point, information related to the SNA network and to identify network problems.
- A hardware monitor, which helps the user to get problem determination information that is generated at resources that are either link-attached or channel-attached to the host system.

As a cohesive set of SNA host network management services, the NetView program offers:

- Consistency and usability in its support for network management
- Easy installation procedure
- Device support
- Operator usability.

The 3745 supports:

- Link Problem Determination Aid (LPDA*) facilities provided by IBM DCEs.
- NetView Performance Monitor (NPM) under VM and MVS.

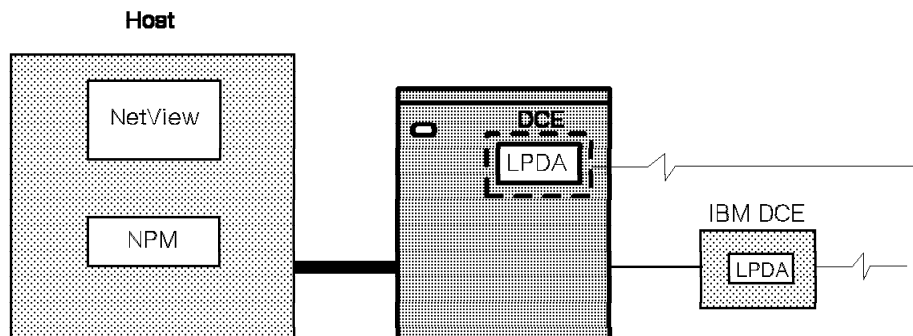

Controller-Resident Programs

The 3745 runs under control of one of the following:

- Advanced Communications Function for Network Control Program (NCP) to support SNA devices.
- Emulation programming (EP) to support non-SNA devices.

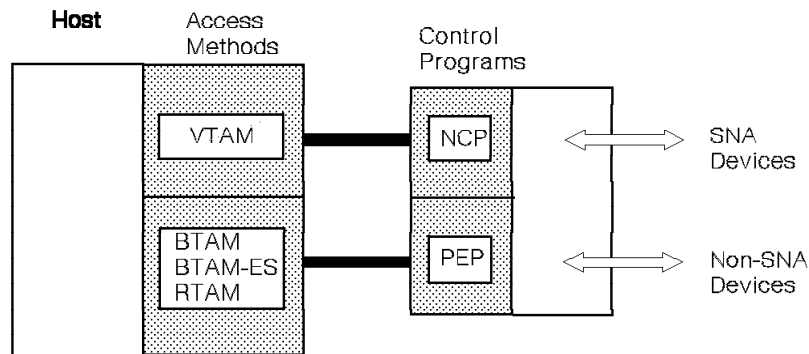

- Partitioned emulation programming (PEP) extension of NCP to support SNA and non-SNA devices.

Network Control Program (NCP)

NCP provides major capabilities for SNA networks with synchronous data link control (SDLC).

Start-stop and binary synchronous terminals and existing networks can be migrated to a 3745 with the IBM Network Terminal Option (NTO) program. For start-stop protocols, NCP supports a variety of transmission codes including ASCII, EBCDIC, EBCD, and BCD. Additionally, it supports a correspondence code for which it provides translation from and to EBCDIC. For the BSC protocol, this support and translation operation is performed by the scanners.

NCP includes the token-ring interconnection functions.

NCP coexists with the following IBM licensed programs:

- Network Routing Facility (NRF)
- Network Terminal Option (NTO)
- X.25 NCP Packet Switching Interface (NPSI)
- X.25 SNA Interconnection (XI)
- X.21 Short Hold Mode/Multiple Port Sharing (X.21 SH/MPS).

Partitioned Emulation Programming Extension

The partitioned emulation programming (PEP) extension of the NCP allows the Network Control Program and the Emulation Program to coexist in the same 3745. The PEP lets the NCP operate certain lines in network control mode while operating others in emulation mode.

The PEP can run only in a channel-attached controller. Channel attachment must be a byte-multiplexer channel, where one emulated subchannel address is specified per EP line.

The PEP emulates most of the functions of the IBM 2701 Data Adapter Unit, IBM 2702 Transmission Control, or IBM 2703 Transmission Control and can communicate with various access methods running in the host. Most programs written for these machines can operate in a 3745 without modification. However, programs that involve timing or special hardware considerations may have to be changed.

Generating and Loading the Control Program

SSP is used on the owning host to generate the control program load module and to load it into the controller storage. The control program for the controller is generated from standard program modules of the NCP library using the NCP definition facility (NDF) procedure. The control program must reflect the required controller configuration. Several control programs can be generated to handle different subsets of lines attached to the same controller.

Multiple Load Module

The network operator can transfer and save one or two CCU load modules onto the integrated hard disk. Either load module can be used at controller initialization.

Automatic Control Program Load

VTAM and the 3745 MOSS allows the automatic IPL/dump capability. For an automatic IPL from the controller disk, the network operator must have assigned this option during NCP loading.

Coexistence and Migration

The 3745 running under NCP can coexist with other IBM communication controllers.

The 3745 supports networks based on the earlier IBM 2701 Data Adapter Unit, IBM 2702 Transmission Control, or IBM 2703 Transmission Control. It also supports networks in which these units are emulated on a 3725 and the 3745 via PEP. PEP permits migration from the 2701, 2702, 2703, and IBM 3704, 3705, 3720, and 3725 communication controllers that run EP.

The IBM Transaction Processing Facility program is supported by NCP.

Configurations with EP only, the IBM Network Extension Facility (NEF), or the IBM Non-SNA Interconnection (NSI) are supported.

The 3745 offers a path for conversion from existing systems and for continuing growth. A system designed for the IBM 3725 or 3720 may be applied to the 3745 after regeneration of the control program. The control program generation deck that was used in the 3725 or 3720 program generation can be used with some modifications to statements (assuming that the controller has the same line configuration).

Maintenance

Preventive Maintenance

The battery is replaced by maintenance personnel.

An alert notifies the customer for battery replacement, and provides the CE with a reference code.

The *Maintenance Information Procedures (MIP)*, SY33-2070, guides the maintenance personnel for replacement procedures.

Maintenance Aids

Tools and Test Equipment

Refer to Appendix A.

Chapter 2. Central Control Unit (CCU)

The CCU in 3745 Models 130, 150, 160, and 170 Data Flow	2-2
The CCU in 3745 Model 17A Data Flow	2-3
General Description	2-4
Data Flow	2-4
Packaging	2-4
Functional Description	2-5
Program Levels	2-5
Interrupts	2-6
Instruction Set	2-10
CCU Environment	2-12
CCU Subsystem Power-ON Reset (POR)	2-13
Main Storage	2-13
Storage Environment	2-14
Direct Memory Access and Storage Control (SCTL)	2-14
CCU-to-Storage Interconnection	2-17
Cache Storage	2-17
Storage Protection	2-18
CCU Timers	2-19
CCU to and from Adapters	2-20
IOC Control Logic	2-20
IOC Data Flow	2-20
Registers	2-21
Hardware Registers	2-42
CCU to and from MOSS	2-43
CCU Diagnostics	2-43
CCU Error Handling	2-44
CCU Error Detection	2-46
Performance Test Points	2-50

The CCU in 3745 Models 130, 150, 160, and 170 Data Flow

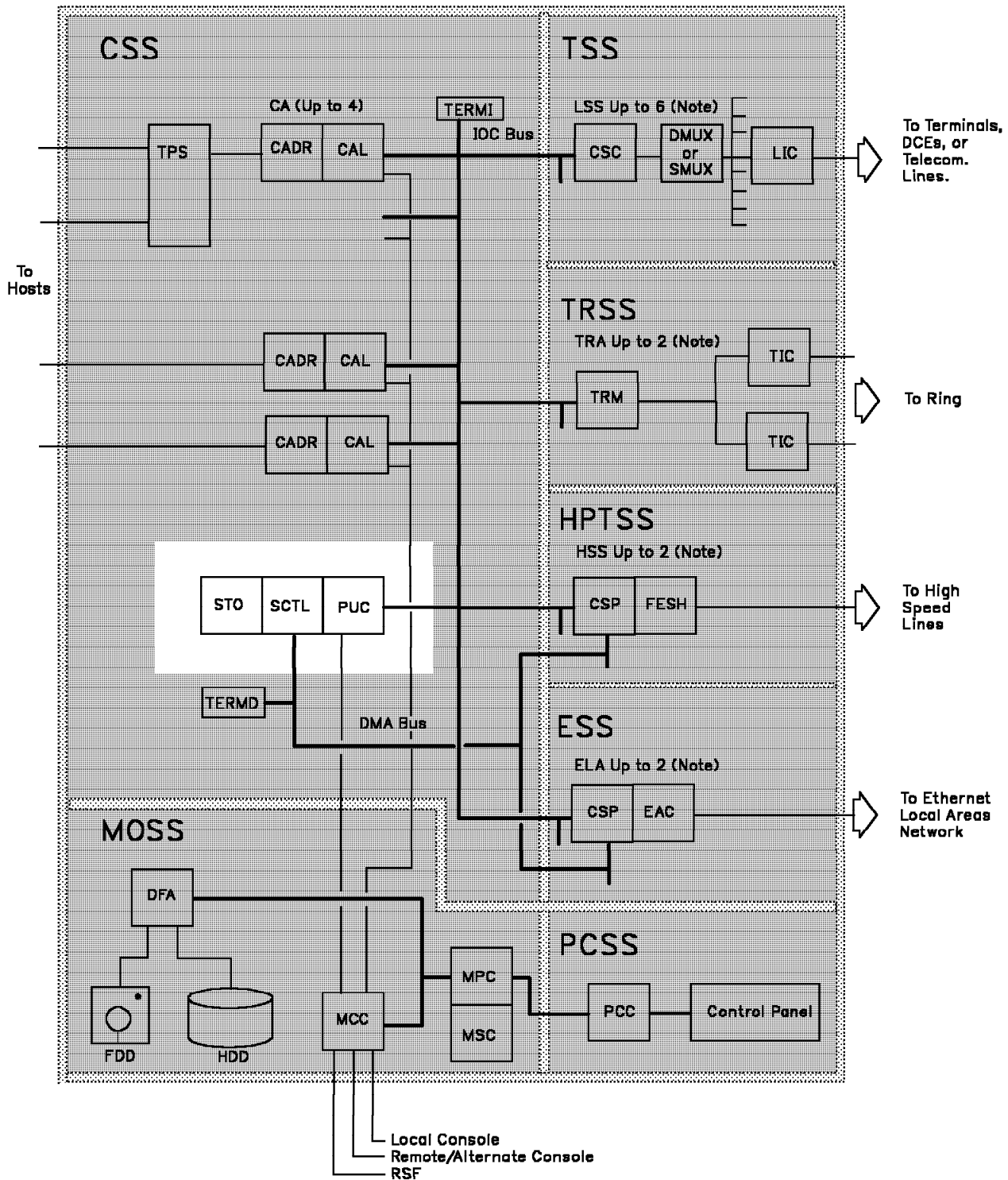

(Note) The number of LSS+HSS+ELA does not exceed 6

The CCU in 3745 Model 17A Data Flow

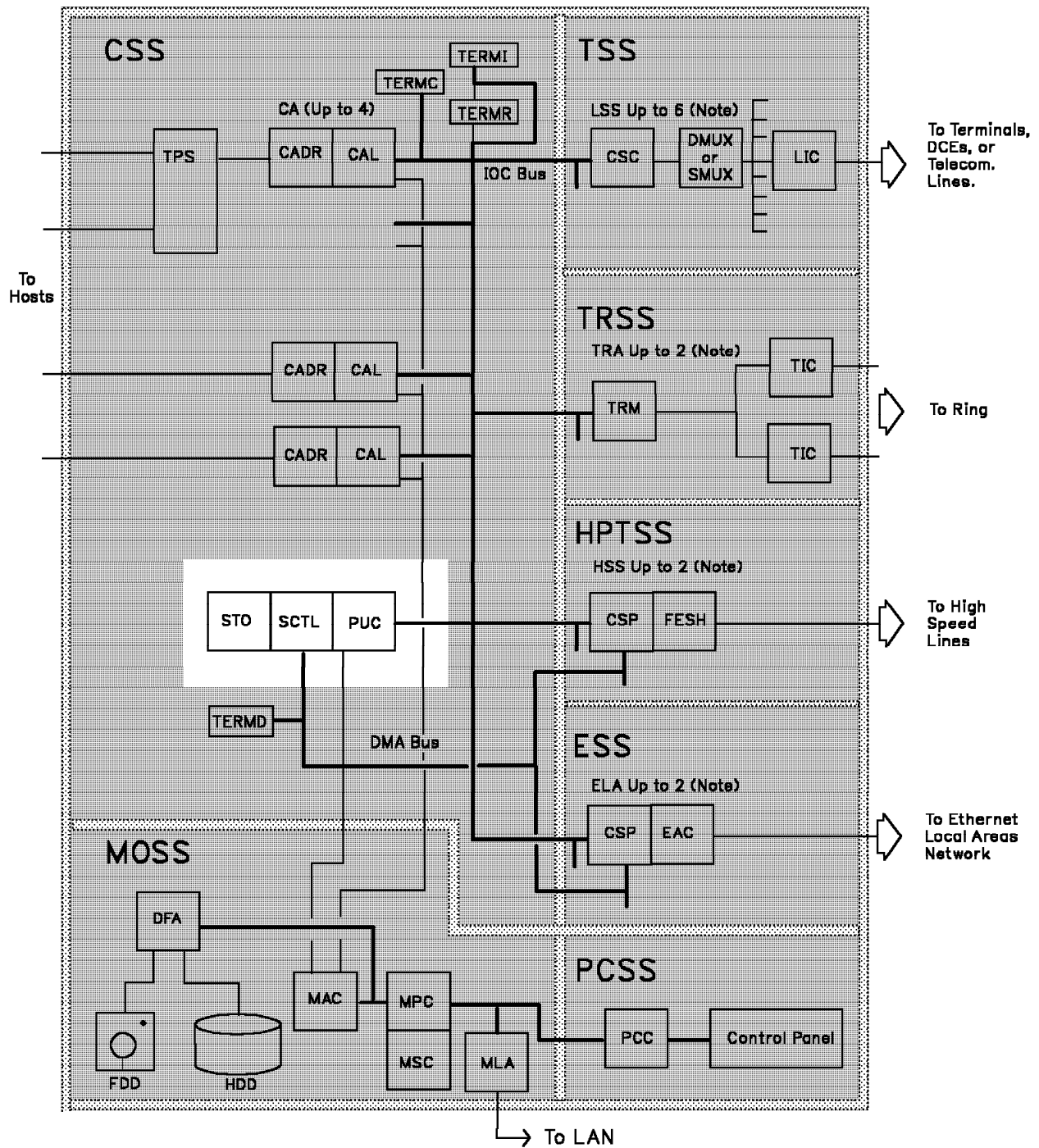

(Note) The number of LSS+HSS+ELA does not exceed 6

Figure 2-1. The CCU in 3745 Model 17A Data Flow. For model 17A, DMA and IOC buses are connected to the CBC in the 3746-900. This MLA card links the MOSS to the Service Processor through a LAN.

General Description

The 3745 is equipped with one CCU.

Data Flow

CSS

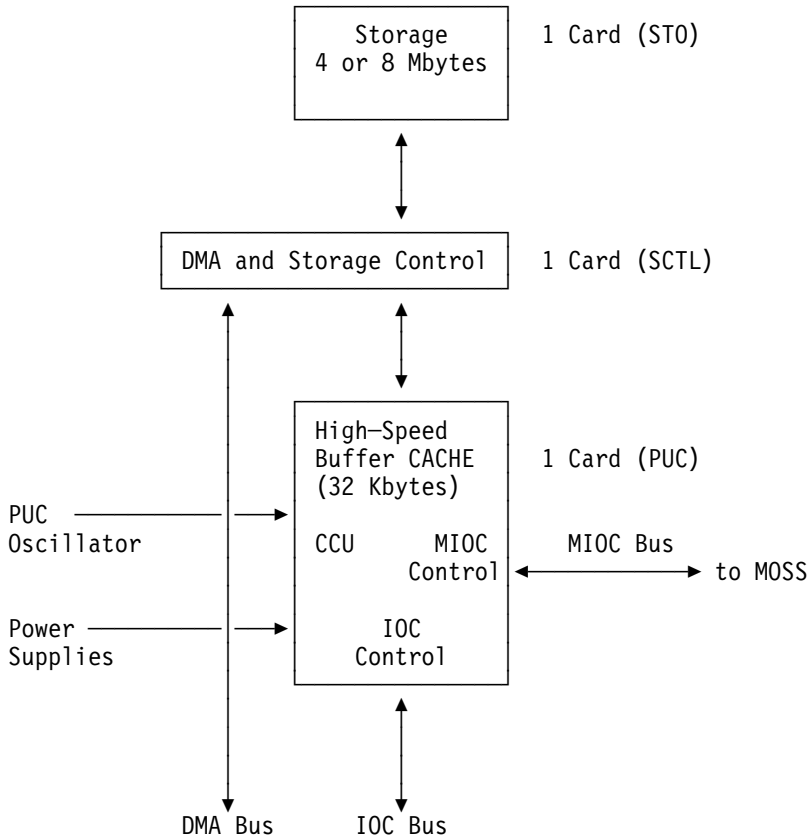

Packaging

See YZ pages for locations.

The communication subsystem (CSS) includes the following components:

- Processor unit card (PUC)
- Storage basic card (STO) 4 or 8 Mbytes
- Storage control card (SCTL).

Functional Description

The central control unit (CCU) is an interrupt-driven processor with a stored program called the 'control program' (CP) in this manual, that controls the data transfers on the channel and transmission interfaces.

The CCU:

- Executes the machine instruction set (CCU cycle=131.6 ns) to perform arithmetic or logical operations, exchange data between main storage and the work registers, and also between the local store and the work registers.

Data transit between the CCU and main storage is achieved via a high-speed buffer (CACHE) under the control of the SCTL logic.

Data can also transit directly between main storage and high-speed adapters via the direct memory access (DMA) logic.

- Communicates with adapters through the input or output control IOC logic in program-initiated operations (PIO) or in adapter input or output operations (AIO) mode:

PIO mode: The exchange operation is initiated by input or output halfword (IOH) or input or output halfword immediate (IOHI) instructions in the CCU.

AIO mode: The operation uses cycle steal for data exchange between adapters and main storage without control program intervention.

One bus (IOC) gives access to the adapters' environment.

- Communicates with the MOSS through the MOSS IOC (MIOC). The operations performed can be direct or indirect (MIOH/MIOHI).

MOSS uses the CCU level sensitive scan design (LSSD) to read or write any CCU discrete latch.

Program Levels

The controller hardware has five operational program levels:

Program level 1

This is the highest priority program level. Interrupt requests assigned to level 1 include all critical check conditions such as CCU checks, program checks, addressing exceptions, and adapter checks. Initial program load (IPL) and address compare interrupts are also handled in this level.

Program level 2

Normal operational interrupt requests from the communication adapters are assigned to this program level and certain program controlled interrupts (PCIs) are also assigned to this level.

Program level 3

Normal operational interrupt requests from the channel adapters, interval timers and program-controlled interrupt 3 (PCI) requests and panel interrupts are assigned to this level.

Program level 4

Certain program controlled interrupt (PCI) requests and the supervisor call (SVC) request (generated when the exit instruction is executed at program level 5), and MOSS request service and request response are assigned to this interrupt program level. This level is the lowest priority interrupt level.

Program level 5

This level is the lowest priority level and is normally active when none of the other four levels requires program cycles.

Masking Program Level Priorities: Programs at levels 1, 2, 3, or 4 can mask all interrupt requests for program levels 2, 3, or 4 and can mask adapter interrupt requests for level 1. Moreover, program execution in level 5 can be masked.

The normal operational priority structure can be changed by output instructions X'7E' and X'7F' (set or reset mask register).

When the mask is set for one or more of program levels 2, 3, or 4, interrupt requests for those levels will not cause an interrupt. When the mask is set for program level 1, requests by adapters for level 1 will not cause an interrupt though any other request will be honored.

When the mask for level 5 is set, the use of machine cycles for program execution in level 5 is prevented. Thus, level 5 program execution is masked. In this case, when no program is executing in levels 1, 2, 3, or 4, the CCU enters the wait state and no program executes.

To selectively mask one or more program levels, one of the active general registers is loaded with the bits corresponding to those program levels to be masked. Output instruction X'7E' (set mask register) is then executed using the general register as input to the mask register. To selectively unmask one or more program levels, the same procedure is followed except that the output X'7F' (reset mask register) instruction is executed.

Interrupts

The communication controller operates in response to requests from either the control program (CP) or the hardware. Since these requests may have varying degrees of urgency, a priority system is used. Each program, CCU and adapter request, is assigned a particular priority level. A request for use of the controller by the control program or hardware functions is called an interrupt request.

Interrupt Mechanism: The interrupt mechanism determines when an interrupt can be handled. If the interrupt request is to be allowed, the change from the active program level to the interrupting program level takes place immediately after completion of the current instruction. If several interrupt requests having different priorities are present at the same time, the one with the highest priority obtains use of the controller. When an interrupt request is granted use of the controller, it can be interrupted in that use by another request having a higher priority.

When an interrupt occurs, instruction execution at the lower priority program level is suspended until instruction execution is completed at the higher priority level. An interrupt to a specific program level prevents future interrupt requests assigned to either that level or to lower priority program level from causing another interrupt until the servicing of the first interrupt is complete.

Interrupt Request Determination: The priority of simultaneous interrupt requests assigned to the same interrupt program level is resolved by the order in which the program tests the set/reset condition of the CCU and adapter interrupt request latches.

Interrupt requests from the CCU and the adapters are grouped together according to their source for ease of identification. The set/reset condition of a specific interrupt request latch can be determined by checking the interrupt request group to which it is assigned. Input X'77' indicates the non-level 1 interrupt requests that are set by the adapters. Input X'7F' indicates the non-level 1 interrupt requests that are set by CCU or program. Input X'7E' indicates all level 1 requests. These inputs load the contents of the appropriate interrupt request group into an active general register. The program may then test the general register to identify the request.

Setting/Resetting Interrupt Requests: A particular interrupt request latch can be set as a result of a hardware-detected condition or, in some cases, by the program through the execution of an output instruction. The latch can be reset by one of several output instructions, depending upon the specific interrupt request. The procedures for setting and resetting individual adapter interrupt requests are described in the adapter sections.

For special service requests, program levels 1, 2, 3, and 4 may issue a program-controlled interrupt (PCI) request to program levels 2, 3, and 4. Output instructions X'7B' (set PCI level 2), X'7C' (set PCI level 3), and X'7D' (set PCI level 4) set the PCI interrupt requests. Certain bits in output X'77' (miscellaneous control) reset the PCI requests and other CCU interrupt requests such as the interval timer level 3 request and the supervisor call (SVC) level 4 request. If any bits are ON in registers X'77', X'7E', X'7F', a request for a particular program level is active and must be reset or masked before the program can execute in a lower level. The following example illustrates the interrupt mechanism.

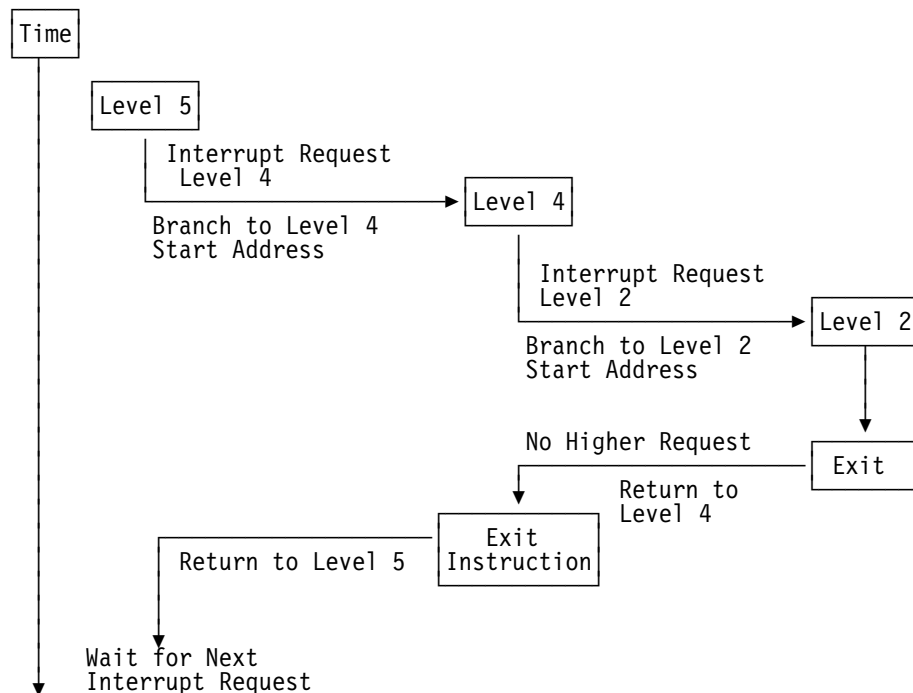

Interrupt Request Sources

Interrupt Level 1

Adapter level 1 request (error)
 Address compare level 1
 Address exception level 1
 Level 5 I/O check level 1
 Protection check level 1
 Invalid operation check level 1
 IPL request level 1
 MOSS inoperative level 1
 Hard error level 1 (Note 1)
 I/O parity error
 I/O time-out error

Interrupt Level 2

Adapter level 2 request (LA)
 Program-controlled interrupt level 2
 MOSS diagnostic level 2

Interrupt Level 3

Adapter level 3 request (CA)
 MOSS diagnostic level 3
 Interval timer level 3
 Program-controlled interrupt level 3
 Panel interrupt request level 3

Interrupt Level 4

Adapter level 4 request (not used)
 Program-controlled interrupt level 4
 MOSS request SVC level 4
 MOSS request response level 4
 SVC level 4 (call from level 5)

Level 5 No interrupt (first entry)

The following figure shows the various links between the different priority levels.

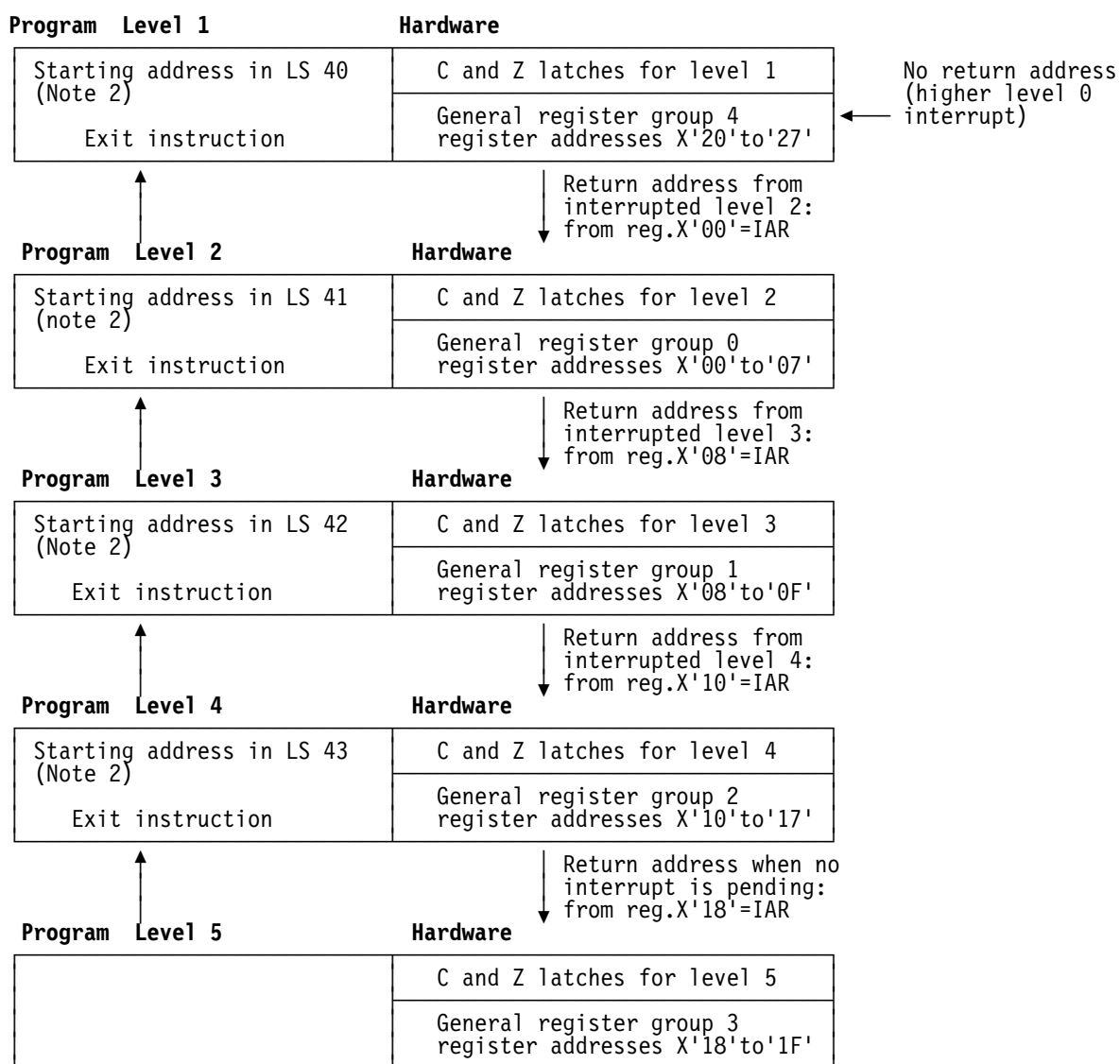

Notes:

1. Hard errors stop the CCU unless it is in bypass mode.
2. The interrupt levels 1, 2, 3, and 4 starting addresses are set during IPL via output instructions X'40' through X'43'.

Instruction Set

The 3745 contains 53 executable instructions.

Any attempt at program levels 2, 3, 4, or 5 to execute an operation code other than one of the 53 specified operations results in a level 1 interrupt with the invalid operation check bit set ON in the CCU interrupt request group 1 register X'7E'.

An attempt to execute an invalid operation code in program level 1 sets the hard error bit in the CCU check register along with an invalid operation check bit. In all cases, execution is suppressed.

For details on instruction operation, refer to *3745 Principles of Operation*, SA33-0102. However, hereafter is the list of instructions with their different formats for quick reference only. The formats are described in detail in the *3745 Principles of Operation*, SA33-0102.

Number of CCU Cycles		Instruction	Format																
No Br (1)	Br (1)		CZ	0	1	2	3	4	5	6	7	8	9	10	11	12	13	14	15
-	3	B	Branch	1	0	1	0	1											+
2	4	BCL	Branch on C latch	1	0	0	1	1							T				-
2	4	BZL	Branch on Z latch	1	0	0	0	1											
3	4	BCT	Branch on count	1	0	1	1	1				1			T				+
2	4	BB	Branch on bit	1	1	M	M	1			M								-
1	-	LRI	Load register immediate	*	1	0	0	0	0										
1	-	ARI	Add register immediate	*	1	0	0	1	0										
1	-	SRI	Subtract register immediate	*	1	0	1	0	0	R	N				I				
1	-	CRI	Compare register immediate	*	1	0	1	1	0										
1	-	XRI	Exclusive OR register immediate	*	1	1	0	0	0										
1	-	ORI	OR register immediate	*	1	1	0	1	0										
1	-	NRI	AND register immediate	*	1	1	1	0	0										
1	-	TRM	Test register immediate	*	1	1	1	1	0										
1	-	LCR	Load character register	*	0			0				0	0	0	0	1	0	0	0
1	-	ACR	Add character register	*	0			0				0	0	0	1	1	0	0	0
1	-	SCR	Subtract character register	*	0			0				0	0	1	0	1	0	0	0
1	-	CCR	Compare character register	*	0	R2	N2	0	R1	N1		0	0	1	1	1	0	0	0
1	-	XCR	Exclusive OR character register	*	0			0				0	1	0	0	1	0	0	0
1	-	OCR	OR character register	*	0			0				0	1	0	1	1	0	0	0
1	-	NCR	AND character register	*	0			0				0	1	1	0	1	0	0	0
1	-	LCOR	Load channel with offset register	*	0			0				0	1	1	1	1	0	0	0

Notes:

1. The number of CCU cycles shown does not include storage cycles when performed after the last CCU cycle (Br= Branch).

Number of CCU Cycles		Instruction		Format																		
No Br (1)	Br (1)			CZ	0	1	2	3	4	5	6	7	8	9	10	11	12	13	14	15		
3	-	ICT	Insert character & count		0				0				0	0	0	1	0	0	0	0		
3	-	STCT	Store character & count		0				0				0	0	1	1	0	0	0	0		
2	-	IC	Insert character	*	0			1	R	N	0					D						
1	-	STC	Store character		0			1														
2	4	LH	Load halfword	*	0		B	0			0					D				1		
1	-	STH	Store halfword		0			0		R	1										1	
3	5	L	Load	*	0			0			0					D				1	0	
2	-	ST	Store		0			0			1									1	0	
1	3	LHR	Load halfword register	*	0			0					1	0	0	0	0	0	0	0	0	
1	3	AHR	Add halfword register	*	0		R2	0		R1			1	0	0	1	0	0	0	0	0	
1	3	SHR	Subtract halfword register	*	0			0					1	0	1	0	0	0	0	0	0	
1	3	CHR	Compare halfword register	*	0			0					1	0	1	1	0	0	0	0	0	
1	3	XHR	Exclusive OR halfword register	*	0			0					1	1	0	0	0	0	0	0	0	
1	3	OHR	OR halfword register	*	0		R2	0		R1			1	1	0	1	0	0	0	0	0	
1	3	NHR	AND halfword register	*	0			0					1	1	1	0	0	0	0	0	0	
1	3	LHOR	Load halfword with offset register	*	0			0					1	1	1	1	0	0	0	0	0	
1	3	LR	Load register	*	0			0					1	0	0	0	1	0	0	0	0	
1	3	AR	Add register	*	0			0					1	0	0	1	1	0	0	0	0	
1	3	SR	Subtract register	*	0			0					1	0	1	0	1	0	0	0	0	
1	3	CR	Compare register	*	0			0					1	0	1	1	1	0	0	0	0	
1	3	XR	Exclusive OR register	*	0			0					1	1	0	0	1	0	0	0	0	
1	3	OR	OR register	*	0			0					1	1	0	1	1	0	0	0	0	
1	3	NR	AND register	*	0			0					1	1	1	0	1	0	0	0	0	
1	3	LOR	Load with offset register	*	0			0					1	1	1	1	1	0	0	0	0	
-	3	BALR	Branch & link register		0		R2	0		R1			0	1	0	0	0	0	0	0	0	
-	3	IOH	Adapter in or out	*	0			0					0	1	0	1	0	0	0	0	0	6 31
		IOHI	Adapter IO immediate	*	0	000	0		R		0	1	1	1	0	0	0	0	0	0	0	6 31
2	-	IN	CCU register in		0			0		R						1	1	0	0			
1	3	OUT	CCU register out		0	E		0					E			0	1	0	0		6 31	
-	3	BAL	Branch and link		1	0	1	1	1	R		0	1							A (2)		
2	3	LA	Load address		1	0	1	1	1			0	0							A (2)		
-	9	EXIT	Exit		0	0	0	0	0	0	0	0	0	1	1	1	0	0	0	0	0	6 31

The figure shown is valid for normal instruction cases.

Notes:

1. The number of CCU cycles shown does not include storage cycles when performed after the last CCU cycle (Br= Branch).
2. The A field contains 22 bits, therefore the branch address is always below four megabytes.

CCU Environment

The figure below shows all interconnections to the CCU.

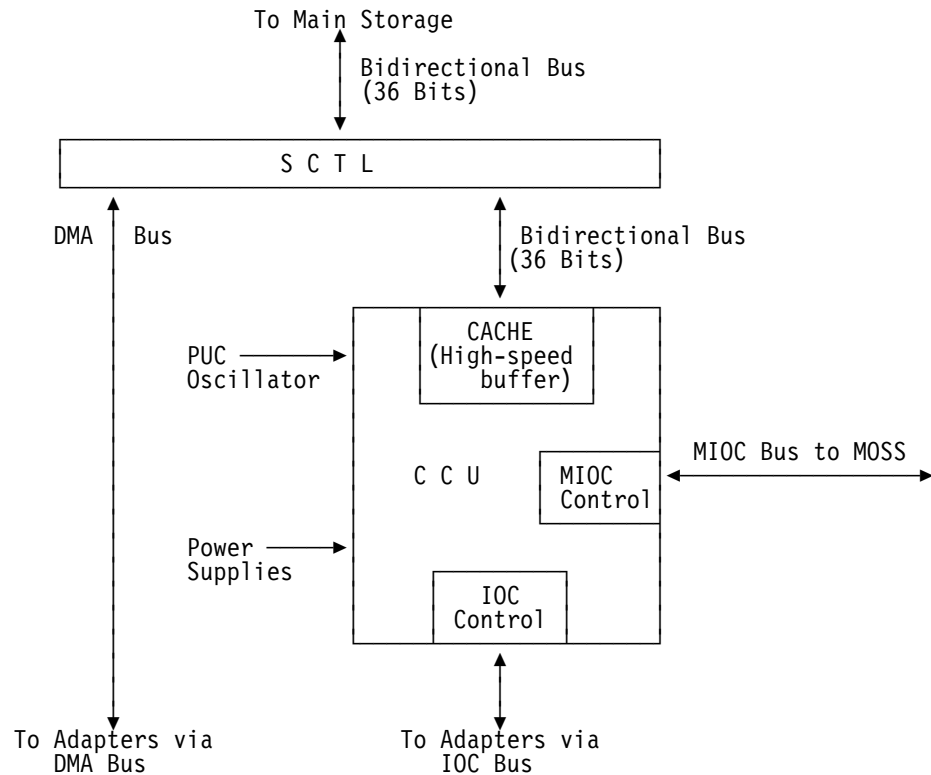

Storage Control Interconnection

Writing data to main storage is performed through the write storage data register (this register is 27 bits wide; 24 data bits + 3 parity bits). Data read from storage is written directly into one or more CCU registers and/or in local storage. Main storage is read and written across the storage data bus (bidirectional, 36 bits wide) which is the only port to/from main storage for the whole machine.

MIOC Interconnection

Through the MIOC interface, the MOSS will be able to obtain or alter the state of 3745.

IOC Bus

This is a multipurpose compatible bus that is used as the base attachment interface for all channel adapters, and line adapters to the CCU.

PUC Oscillator Interconnection

The PUC 53.1914 MHz quartz oscillator signal is used by the CCU to generate its timings.

Power Interface

The power interface provides the CCU with all necessary power voltage requirements needed to operate all 3745 functions.

CCU Subsystem Power-ON Reset (POR)

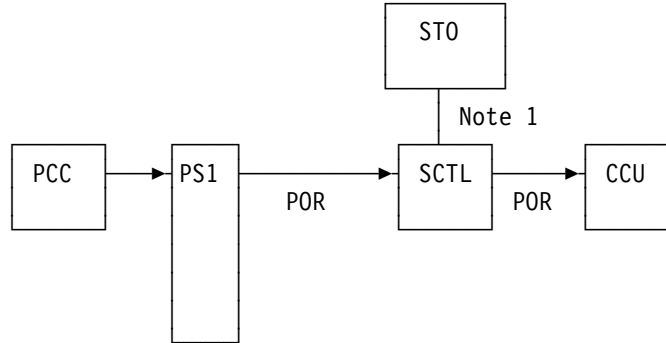

Note: STO is zeroed.

POR is activated at the machine power ON, or at machine reset. The MOSS code can ask the PCC to activate the POR line.

Storage control

At the end of the POR signal, the following sequence of 'warm up' storage is started.

1. Clear all latches and counters,
2. Then, perform 128 cycles to initialize storage,
3. Perform one cycle to configure storage type and size,
4. Then, blank storage with proper ECC.

During all that time, incoming requests are inhibited.

Main Storage

The main storage contains the control program. It is packaged on one card of 4 or 8 Mbytes.

The storage word consists of 4 bytes, referenced as follows:

Y	X	0	1
0 7	0 7	0 7	0 7

The bytes are addressed from the storage address register, which is 27 bits wide.

Storage Environment

The main storage communicates with:

1. The CCU via the storage control (SCTL)
2. The high-speed adapters via the direct memory access bus (DMA bus) through the SCTL.

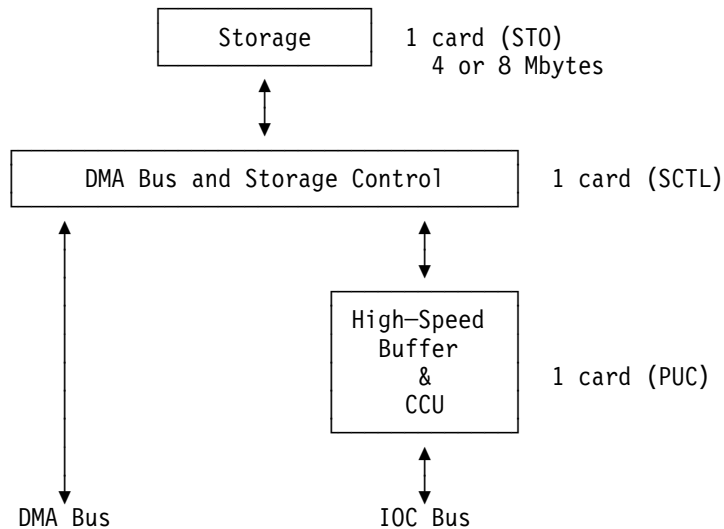

Direct Memory Access and Storage Control (SCTL)

The direct memory access and storage control functions are packaged on one card (SCTL) and the main functions are the following:

- Allocate main storage access to the different users (CCU via the cache storage), and high-speed adapters via the DMA function of the SCTL).
- Control the different storage operations and ensure data transfer integrity:
 - CCU read and write
Write requests are buffered in SCTL so that the CCU and the storage operations can overlap.
 - Cache storage line loading
 - DMA burst transfers.
The data is aligned and temporarily stored in a buffer so as to optimize the use of storage bandwidth.
- Control the cache operations (line loading). Maintain cache consistency with storage during DMA write operations, by means of a cache line invalidation mechanism.
- Check for unauthorized DMA write operations with a DMA storage protect mechanism.

Function Partitioning

The SCTL card can be partitioned into three distinct functional parts:

- The central control unit interconnection (CCUI) logic
- The direct memory access (DMA) logic
- The storage control (MCTL) and, error checking and correction (ECC) logic.

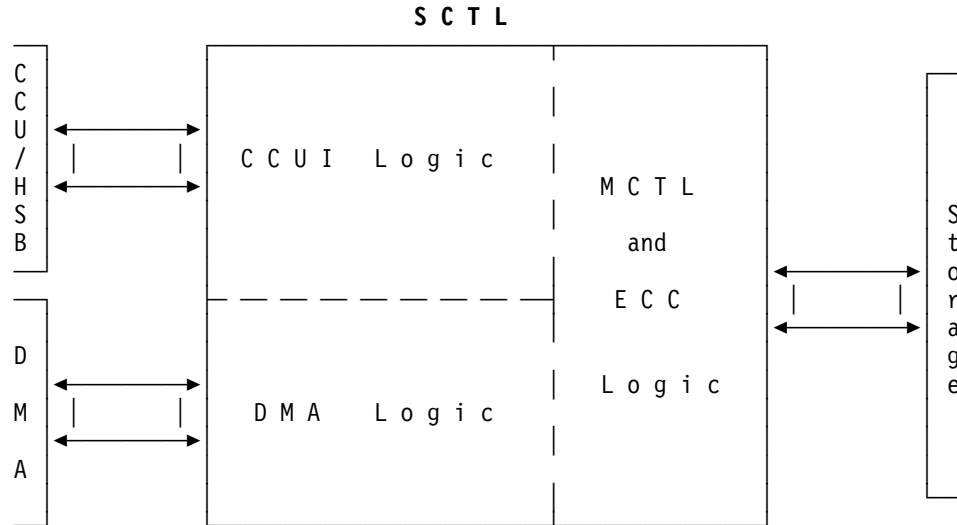

CCUI logic

The CCUI logic interconnects the CCU cache storage. It receives and buffers requests from CCU/cache and controls cache line loading. It controls cache line invalidation and accesses the DMA storage protect RAM (during DMA write operations) on behalf of the DMA logic. The CCUI logic makes storage requests to the MCTL/ECC.

DMA Logic

The DMA logic interconnects the DMA bus on which the high-speed adapters are hooked. It receives requests from the high-speed adapters. It performs data alignment, reads or writes its DMA buffer and makes storage requests to the MCTL and ECC. During a DMA write storage transfer, it makes requests to the CCUI logic for cache line invalidations and for access to the DMA storage protect RAM.

MCTL and ECC

The MCTL and ECC interconnects the storage. It receives storage requests from the CCUI logic and the DMA logic. It performs arbitration between these two users, accesses storage and controls the ECC mechanism.

The storage control contains an error correction code (one word) which is permanently stored, either with its original parity or inverted, thus allowing to correct at least one error in addition to the one-bit correction.

The correcting capability of the ECC depends on the type of bit error, whether it is a hard error (storage position stuck to 0 or 1), or a soft (transient) error.

The correction coverage is the following:

Type of Fault	Coverage
One hard	100%
One soft	100%
One hard and one soft	100%
Two hard	100%
Two hard and one soft	50%
Two soft	0%

SCTL-to-CCU Cache Interconnection

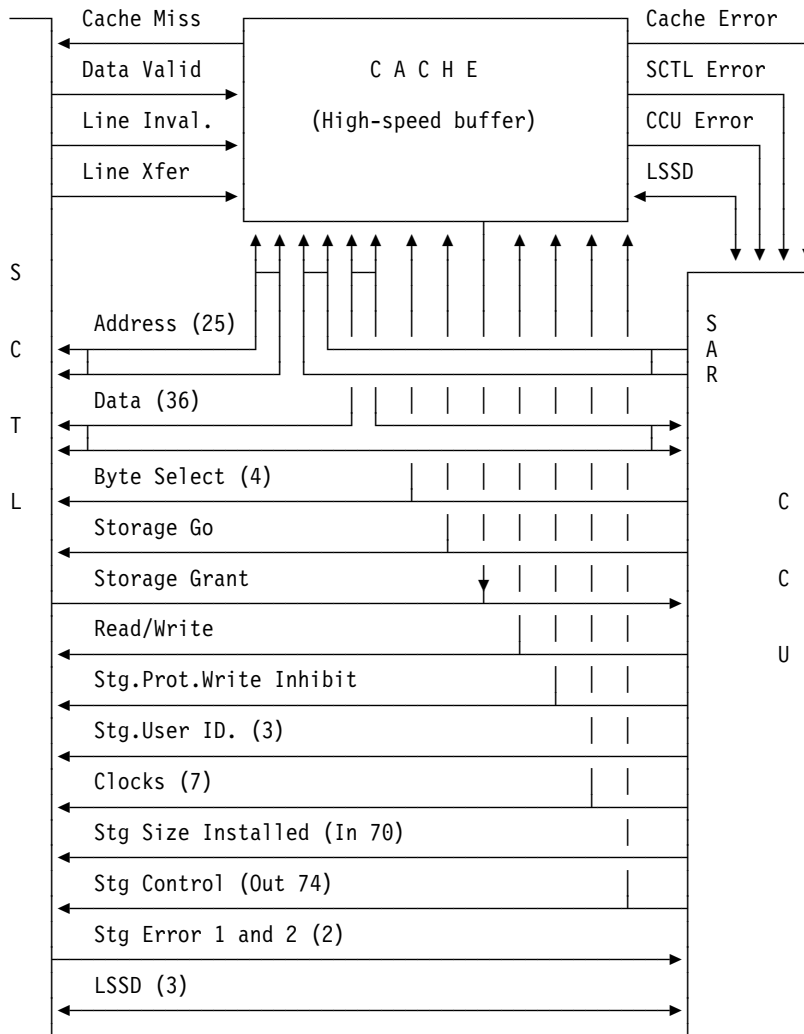

Storage Control Mode

See the output X'74' instruction on page 2-30.

CCU-to-Storage Interconnection

Cache Storage

The cache storage, packaged on the PUC together with the CCU, provides the CCU with instructions and data at cycle rate.

If the instruction or data is not in the cache when it is fetched, the 16 contiguous bytes are automatically transferred into the cache. The probability is high that the next instruction(s) or data will be in those 16 bytes, then, as long as instructions and data are found in the cache, the CCU is not slowed down by main storage and can run at full speed.

Cache Storage Organization

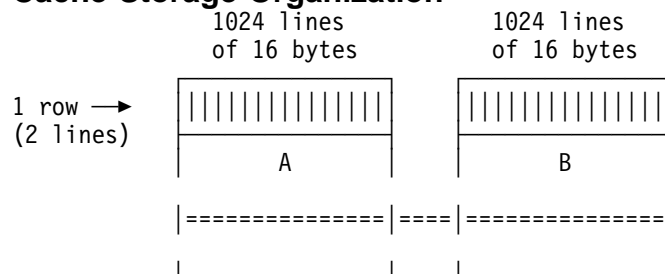

On CCU request, the cache can either write one byte, one halfword, or one fullword. However, the cache is always loaded from storage with 16 contiguous bytes forming a line. The 32K cache is made of 2048 x 16-byte lines and its directory is two-set associative. Cache organization is thus: 1024 rows x 2 sets x 16 bytes. The following table summarizes the various cache data path functions:

Request	Storage User	Cache Function	Management
Read	I-fetch prog. read	Hit: cache read Miss: line loaded from storage + cache read	LRU update LRU update
	Other than I-fetch and prog. read	Hit: cache read Miss: storage read	LRU update —
Write	Any user	Hit: cache write + storage write Miss: storage write	LRU update —
Line Invalidate	DMA	Invalidate a line in the cache	LRU update

LRU: Least recently used

HSB is controlled by means of an X'74' out instruction.

Write Policy

Write requests are always presented both to the cache and main storage (store-through policy). The write request is sent to storage but as soon as it is accepted by the SCTL, the CCU proceeds to the next instruction without waiting for storage update completion. This policy ensures that cache and storage are always consistent with each other and minimizes housekeeping when a cache line must be replaced.

Since on a write request, main storage is always updated (regardless of cache hit or miss), and since the CCU does not wait for write completion, there would be no gain in loading a line in the cache in case of a cache miss. This new line would most probably replace a more useful line in the cache. Therefore, the cache is not loaded with a new line on a write miss.

Read Policy

A CCU read request can come from different sources. The source (called the storage user) can be: The MOSS, the branch trace, the prefetch mechanism, the program, or the IOC (cycle steal mode).

In order to increase the cache hit ratio, the cache is loaded with a new line only when a read miss is caused by an I-fetch or a program read. Any other storage user causing a read miss, results in the data being loaded directly from memory to the CCU without cache involvement.

Line Invalidation

Because of DMA operation, the SCTL requests the cache to invalidate a line. An invalidation request has priority over a CCU request.

When a line invalidation is requested, the SCTL raises the line 'invalid line', which instructs the cache not to propagate the storage address register (SAR) to the storage address data (SAD) bus and to latch the address presented by the SCTL. In the cycle following the address transfer, the cache invalidates the line in the cache and the SCTL ignores requests at the interconnection.

Storage Protection

Storage Protect and Address Exception (SP/AE)

Storage protect is a means of notifying the control program whenever the contents of storage are accessed for unauthorized modification or unauthorized code execution. Attempts to modify storage and attempts to execute instructions are monitored by the following three mechanisms:

1. Address exception based on address exception key.
2. Storage protect based on read-only key.
3. Storage protect based on storage protection key and user key.

Main Storage Protection State

With the storage protect and address exception mechanism, a main storage position can be placed in any of the following states:

- Write free
- Write and instruction fetch controlled
- Read-only
- Write or/and read forbidden.

Storage Protect and Address Exception Instructions

The CCU controls the storage protect and address exception instructions (SP/AE) mechanism with the input X'73' and output X'73' instructions.

SP/AE Keys

Address Exception Key

This key indicates whether an 8-Kbyte block of storage is accessible.

Read Only Key

This key indicates whether a 4-Kbyte block of storage is in the read-only state. For example, machine configuration data is placed in such a storage block.

Storage Protection Key

This key determines the key value (3 bits) for writing in a defined 4-Kbyte block of storage.

User Key

Every user is assigned a 3-bit register that holds the storage protection key it must use for writing in storage and to fetch instructions for execution.

For more details, refer to *Principles of Operations*, SA33-0102.

SP/AE Key Locations

The storage keys are located in a local storage (storage key RAM) and the user keys are located in registers.

To perform the necessary initialization, the program must execute output X'73' instructions for setting the storage keys for all installed 4-Kbyte blocks of storage and up to 6 output X'73' instructions for setting the user keys.

CCU Timers

Two timers are available in the CCU. They are the 100 ms interval timer and the high/low resolution timer.

100 ms Interval Timer

Every 100 ms, this timer requests a CCU level 3 interrupt. Output X'77', byte 1, bit 1 ON is used to reset the timer interrupt. The 100 ms timer is used to:

- Maintains a count of realtime in storage
- Perform long and short time outs
- Perform supervisory functions on a cyclic basis.

High and Low Resolution Timer

The high and low resolution timer does not raise any interrupts. It is driven by clock pulses (every 131.6 ns). Output X'7A' selects the mode and initializes the current timer value to X'00'. Input X'7A' reads the current timer value.

CCU to and from Adapters

The CCU interconnects with the various adapters via the IOC bus. Refer to the Chapter "IOC Bus" for details.

IOC Control Logic

Data, address, and control information exchanges take place between the CCU work registers and the adapters attached to the I/O bus. They use the IOC control logic.

The IOC logic, located in the PUC, operates in two different ways, depending on whether the program initiates the operation (PIO), or an adapter initiates it (AIO).

The data bus carries interrupt requests from the adapters (levels 1, 2, and 3) when it is not busy with PIO or AIO operations.

IOC Data Flow

The I/O bus is an 18-bit (16 for data + 2 for parity) bidirectional bus with necessary tags and controls.

D Register: It is an 18-bit (16 for information + 2 for parity) register. It is the buffer used with the IOC bus for the exchange of all addresses, commands and data to and from the adapters.

A Register: It is a 27-bit (24 for information + 3 for parity) register. In an IOH/IOHI operation it is loaded by the R1 field. In AIO operations it contains the cycle steal address.

The IOC bus operations are under the control of the IOC control logic using a handshaking protocol between the CCU and the adapters.

Level 2 and Level 3 Interrupt Reporting

IOC byte 1, bit 0 produces a single CA level 3 interrupt request to the CCU.
IOC byte 0, bit 1 produces a single LA level 2 interrupt request to the CCU.
After interrupt recognition, the CCU executes an input X'77' instruction to identify the level 2 and 3 interrupt request origin. (see input X'77' in this chapter.)

Input X'77' byte 0 is dedicated to level 2 interrupts, and byte 1 to level 3. The input X'77' bits are then set according to the logical rules.

Level 1 Interrupt Reporting

IOC bus byte 0, bit 5 produces a single CA level 1 interrupt request.

IOC bus byte 1, bit 5 produces a single LA level 1 interrupt request.

After interrupt recognition, the CCU executes an input X'7E' instruction to identify the level 1 interrupt request origin. (see input X'7E' in this chapter.)

When the CCU executes the input X'76' instruction, the bit assignment of byte 0 is for IOC.

Cycle Steal Pointer Allocation

The IOC bus may address up to four channel adapters. The cycle steal pointer registers are allocated as follows:

Adapter	IOC	Pointer type
CAs	30 - 37	Dedicated (NCP)
LAs (CSC, HPTSS)	3F	Shared pointer

For all AIO operations, bit 5 = 0 for CA, bit 5 = 1 for LA and bits 11-14 (pointer number if bit 5 = 0 and scanner ID if bit 5 = 1) of the CSCW are stored in an external register accessible by the control program using input X'75'. (See input X'75' in this chapter.)

Reset or Stop Adapter Input or Output

See output X'76' and output X'79' in this chapter.

Registers

The controller has two types of register: general and external.

General Registers

Forty general registers are available in the controller for program use. The size of each register is 24 bits. The bits are assigned from left to right as byte X, bits 0-7; byte 0, bits 0-7; and byte 1, bits 0-7.

The forty registers are divided into five groups of eight registers each. Each group is assigned to a specific program level. Only one group of general registers is active at a given time (the group associated with the active program level). The registers within the currently active group are directly addressable with program instructions. The control program can access the general registers by specifying them as external registers in input and output instructions.

Instruction Address Register: General register 0 in each group is the instruction address register (IAR). This register is an implied base register and contains the address of the next instruction to be executed for the associated program level. Register 0 of the active group is always incremented to point to the next sequential instruction before the current instruction is executed. However, execution of a branch instruction can cause the IAR to be loaded with a storage address other than that of the current instruction.

External Registers

External registers are registers which are not directly accessible by the control program. Therefore, by using an input instruction, the control program can load the contents of an external register into a general register where it can operate on the data. By using an output operation, the control program can load an external register with the contents of the general register specified in the instruction.

CCU external registers are located in:

- The local store (LS address X'00' to X'7F')

The local store registers at address X '00 to 27' are the five groups of eight general registers. Each group is associated to one program level.

- The hardware registers:
 - Seven work registers
 - Instruction address register (IAR)
 - Lagging address register (LAR).

See “Hardware Registers” on page 2-42 for details.

- Hardware latches

The following tables, list the input and output instructions.

Input Instructions

Input	Register Function	Local Storage Register
00 - 07	General register group 0 (level 2)	00 - 07
08 - 0F	General register group 1 (level 3)	08 - 0F
10 - 17	General register group 2 (level 4)	10 - 17
18 - 1F	General register group 3 (level 5)	18 - 1F
20 - 27	General register group 4 (level 1)	20 - 27
28 - 2F	Not used	
30 - 37	IOC-CA pointer register 0-7	30 - 37
38 - 3E	Not used	38 - 3E
3F	IOC-CSP pointer register F	3F
40	Program interrupt start address level 1	40
41	Program interrupt start address level 2	41
42	Program interrupt start address level 3	42
43	Program interrupt start address level 4	43
44	Byte-addressable base register	44
45	Halfword addressable base register	45
46	Fullword addressable base register	46
47	CCU SCTL/cache control	47
48	IOH TA substitution	48
49 - 4F	Not used	
50 - 5F	Reserved for program use (see Note 1)	50 - 5F
60 - 67	Not used	60 - 67
68	Zero register	68
69	Holding register for IOH, IOHI, BAL instruction	69
6A	Holding register for MOSS IOH	6A
6B	Holding register for IOHI	6B
6C - 6E	Not used	
6F	Not used	6F
70	Storage size installed	Hardware register
71	Operator address or data entry register	71
72	Operator function select controls	72
73	Read SP/AE key	Hardware register
74	LAR	Hardware register
75	AIO CCW	Hardware register
76	IOC level 1 interrupt requests	Hardware register
77	Adapter level 2, 3 or 4 interrupt requests	Hardware register
78	Not used	
79	Utility	Hardware register
7A	High-resolution timer value	Hardware register
7B	Branch trace address pointer	7B
7C	Branch trace buffer count	7C
7D	CCU hard errors register	Hardware register
7E	Level 1 interrupt requests	Hardware register
7F	CCU level 2, 3 or 4 interrupt requests	Hardware register

Notes:

1. Unassigned fullword registers are available for the program at this location.
2. If the control program tries to read locations 28-2F, 38-3E, 49-4F, 6C-6E, 78 an invalid operation condition is detected and a level 1 interrupt is set.

Output Instructions

Outputs	Register/Function	Local Storage Register
00 - 07	General register group 0 (level 2)	00 - 07
08 - 0F	General register group 1 (level 3)	08 - 0F
10 - 17	General register group 2 (level 4)	10 - 17
18 - 1F	General register group 3 (level 5)	18 - 1F
20 - 27	General register group 4 (level 1)	20 - 27
28 - 2F	Not used	
30 - 37	IOC-CA pointer register 0-7	30 - 37
38 - 3E	Not used	38 - 3E
3F	IOC-CSP pointer register F	3F
40	Program interrupt start address level 1	40
41	Program interrupt start address level 2	41
42	Program interrupt start address level 3	42
43	Program interrupt start address level 4	43
44	Byte-addressable base register	44
45	Halfword-addressable base register	45
46	Fullword-addressable base register	46
47	CCU SCTL/cache control	47
48	IOH TA substitution	48
49 - 4F	Not used	
50 - 5F	Reserved for programs use	50 - 5F
60 - 67	Not used	60 - 67
68	Zero register	68
69	Holding register for IOH,IOHI, BAL instruction	69
6A	Holding register for MOSS IOH	6A
6B	Holding register for IOHI	6B
6C - 6E	Not used	
6F	Not used	6F
70	Hard stop	Hardware register
71	Display register 1	Hardware register
72	Display register 2	72
73	Write/select SP/AE key	Hardware register
74	Storage control	Hardware register
75	Not writable	
76	Miscellaneous control	Hardware register
77	Miscellaneous control	Hardware register
78	Not used	Hardware register
79	Utility	Hardware register
7A	Resolution/utilisation counter control	Hardware register
7B	Set PCI level 2	Hardware register
7C	Set PCI level 3	Hardware register
7D	Set PCI level 4	Hardware register
7E	Set mask bits	Hardware register
7F	Reset mask bits	Hardware register

Note:

If the control program tries to read locations 28-2F, 38-3F, 49-4F, 6C-6F, 75 an invalid operation condition is detected and a level 1 interrupt is set.

Input/Output X'7x' Instructions

The control program uses input and output instruction to access CCU registers and/or to control and monitor the status of the CCU.

Input Instructions

Input X'70' (storage size installed):

This instruction loads a general register with a combination of bits that indicates the amount of storage installed.

Input X'71' (operator address or data entry register):

This instruction loads a general register with a combination of bits to indicate data to be used in a control panel function.

Input X'72' (operator function select control):

This instruction loads a general register with a combination of bits to indicate the operator display or function select. Through the use of this instruction, the program can accept information from the operator.

Input X'73' (read storage protection or address exception key):

This instruction loads a general register with the storage protect or address exception key addressed by the last output X'73' instruction executed.

Input X'74' (lagging address register):

This instruction loads a general register with the contents of the lagging address register. When this input is executed, the address transferred into the general register is that of the last instruction executed before the input instruction (this might not be true in case of error. Refer to *Principles of Operations Manual*. for more information).

Input X'75' (AIO channel control word):

This instruction loads a general register with bits of the CCW received by the IOC for an AIO which has been suspended or stopped due to an error detected by the hardware. Otherwise, the data loaded in this general register is NOT valid.

Input X'76' (IOC level 1 interrupt requests):

This instruction loads a general register with information that can be used to determine the type of error encountered.

Input X'77' (adapter level 2, 3, or 4 interrupt requests):

This instruction loads a general register with information that can be used to determine which adapter type caused a level 2, 3, or 4 interrupt.

Input X'79' (utility):

This instruction loads a general register with utility information. When it is executed in program level 1, byte 1, bits 0-3 designate the program level that was operating before the level 1 interrupt. When it is executed in program levels 2, 3, or 4 (or level 1 if level 1 is re-entered immediately after a level 1 exit), byte 1, bits 0-3 have no significance and are set to zero. When input X'79' is executed at any level, byte 0, bits 6 and 7 indicate the state of the program level 5, C, and Z condition latches.

Input X'7A' (high-resolution timer):

This instruction loads a general register with the high-resolution timer.

Input X'7B' (BT address pointer):

This instruction loads a general register with the branch trace address pointer.

Input X'7C' (BT buffer count):

This instruction loads a general register with the branch trace buffer count.

Input X'7D' (CCU hard errors register):

This instruction loads a general register with information showing which CCU hard error has been detected.

Input X'7E' (program level 1 interrupt requests):

This instruction loads a general register with bits to indicate interrupt requests for program level 1 interrupt. Also shown is the CCU hard error summary bit.

Input X'7F' (level 2, 3, or 4 interrupt requests):

This instruction loads a general register with bits to indicate interrupt requests for program levels 2, 3, and 4.

Output Instructions

Output X'70' (hard stop):

This instruction causes the CCU to enter a hard stop state. In this state, program execution, program interrupts and adapter cycle steals are prevented. The bit settings of the general register are ignored.

Output X'71' (display register 1):

This instruction loads the contents of the general register into display register 1.

Output X'72' (display register 2):

This instruction causes the contents of the general register to be loaded into display register 2.

Output X'73' (read storage protection or address exception register):

This instruction causes the contents of the general register to be used to address and or set the storage and protect keys.

Output X'74' (storage control):

This instruction causes the contents of the general register to be used to control the operational mode of the cache and the SCTL/ECC mechanism.

Output X'76' and Output X'77' (miscellaneous control):

These instructions cause the contents of the specified general register to be used to set or reset various interrupt requests.

Output X'79' (utility):

This instruction causes the contents of the specified general register to set or reset various hardware latches. It permits 'set IPL request' (byte 0 bit 2). This results in an interrupt to MOSS. It does not stop the control program. If the control program is to stop after setting an IPL request, by using the output X'70' instruction a hard stop must be sent by the control program in addition to output X'79'. It permits remote power OFF (bit 0.4). A remote power OFF line is sent to the power subsystem.

Output X'7A' (utilization counter):

This instruction causes the contents of the specified general register to control the high-resolution timer and the utilization counter.

Output X'7B' (set PCI level 2):

This instruction causes a program-controlled interrupt request to be set for program level 2 (PCI level 2). This allows a program level to transfer a processing requirement to a different priority program level. The bit settings of the general register are ignored. A PCI interrupt request is immediately effective.

Output X'7C' (set PCI level 3):

This instruction causes a program-controlled interrupt request to be set for program level 3 (PCI level 3). This allows a program level to transfer a processing requirement to a different priority program level. The bit settings of the general register are ignored. A PCI interrupt request is immediately effective.

Output X'7D' (set PCI level 4):

This instruction causes a program-controlled interrupt request to be set for program level 4 (PCI level 4). This allows a program level to transfer a processing requirement to a lower priority level. The bit settings of the general register are ignored. A PCI interrupt request is immediately effective.

Output X'7E' (set mask bits):

This instruction causes the mask bits of the program levels to be set according to the contents of the general register. When a mask bit is set ON, interrupt requests for the program level that corresponds to that bit are ignored. When the mask bit for program level 5 is ON, program execution at that level is not allowed.

Output X'7F' (reset mask bits):

This instruction causes the mask bits of the program levels to be reset according to the contents of the general register. If an interrupt for a particular level is pending when the mask bit for that level is reset, an interrupt for that level will occur before the next instruction is executed.

Input and Output X'7x' Register Bits

X'70'	Input: Storage Size Installed	Output: Hard stop
Byte X, Bit 0	0	Ignored
1	0	Ignored
2	0	Ignored
3	0	Ignored
4	0	Ignored
5	0	Ignored
6	0	Ignored
7	0	Ignored
Byte 0, Bit 0	I	Ignored
1	I	Ignored
2	I	Ignored
3	I Bit setting depending	Ignored
4	I on storage size.	Ignored
5	I See Table below.	Ignored
6	I	Ignored
7	I	Ignored
Byte 1, Bit 0	0	Ignored
1	0	Ignored
2	0	Ignored
3	0	Ignored
4	0	Ignored
5	0	Ignored
6	0	Ignored
7	0	Ignored

Byte 0 Bit Setting

Storage Size	Storage Card	Input: Byte 0 Bits 0 1 2 3 4 5 6 7 P
4	1 card	0 0 X X X 0 0 1 X
Illegal	Wrong	0 1 X X X X X X X

Notes:

1. Byte 0 bits 2, 3, 4 carry the EC level of the SCTL cards.
2. A good parity is delivered to CCUI and DMA (it includes the EC bits).
3. If no card is installed, a storage control error is reported to CCUI and DMA.

X'71'	Input: Operator Address/Data (LS) Entry Register	Output: Program Display Register 1 (DR1)
Byte X, Bit 0	Addr/Data Byte X, Bit 0	DR1 Byte X, Bit 0
1	1	1
2	2	2
3	3	3
4	4	4
5	5	5
6	6	6
7	7	7
Byte 0, Bit 0	Addr/Data Byte 0, Bit 0	DR1 Byte 0, Bit 0
1	1	1
2	2	2
3	3	3
4	4	4
5	5	5
6	6	6
7	7	7
Byte 1, Bit 0	Addr/Data Byte 1, Bit 0	DR1 Byte 1, Bit 0
1	1	1
2	2	2
3	3	3
4	4	4
5	5	5
6	6	6
7	7	7

X'72'	Input: Operator Function Select Control	Output: Program Display Register 2 (DR2)
Byte X, Bit 0	0	DR2 Byte X, Bit 0
1	0	1
2	0	2
3	0	3
4	0	4
5	0	5
6	0	6
7	0	7
Byte 0, Bit 0	Function select 8	DR2 Byte 0, Bit 0
1	Function select 9	1
2	Function select A	2
3	Storage address	3
4	Register address	4
5	Function select B	5
6	Function select C	6
7	Function select D	7
Byte 1, Bit 0	Function select E	DR2 Byte 1, Bit 0
1	Function select 1	1
2	Function select 2	2
3	Function select 3	3
4	Function select 4	4
5	Function select 5	5
6	Function select 6	6
7	Function select 7	7

Storage Protection Storage Exception X'73'	Input:	Output:
Byte X, Bit 0	0	SKA bit 0
1	0	SKA bit 1
2	0	SKA bit 2
3	0	SKA bit 3
4	0	SKA bit 4
5	0	SKA bit 5
6	0	SKA bit 6
7	0	SKA bit 7
Byte 0, Bit 0	0	SKA bit 8
1	0	SKA bit 9
2	0	SKA bit 10
3	0	SKA bit 11 or UKA bit 0
4	0	UKA bit 1
5	0	UKA bit 2
6	0	UKA bit 3
7	0	UKA bit 4
Byte 1, Bit 0	0	Ignored
1	0	Enable SP or AE
2	0	I 00=user key 10=exception key
3	0	I 01=stor. key 11=read only key
4	0	Modify key value
5	Key value bit 0	Key value bit 0
6	Key value bit 1	Key value bit 1
7	Key value bit 2	Key value bit 2

If byte 1 bits 1, 2, 3 = 1, 1, 0, the storage is not installed for exception key.
If byte 1 bits 1, 2, 3 = 1, 1, 1, prevent write for read-only key.

X'74'	Input: Lagging Address Register (LAR)	Output: Storage Control
Byte X, Bit 0	LAR Byte X Bit 0	I
1	1	I
2	2	I
3	3	I See Output: Byte X next
4	4	I
5	5	I
6	6	I
7	7	I
Byte 0, Bit 0	LAR Byte 0 Bit 0	Not used
1	1	Not used
2	2	Not used
3	3	Not used
4	4	Not used
5	5	Not used
6	6	Not used
7	7	Not used
Byte 1, Bit 0	LAR Byte 1 Bit 0	Not used
1	1	Not used
2	2	Not used
3	3	Not used
4	4	Not used
5	5	Not used
6	6	Not used
7	7	Not used

Output: Byte X, Bit	0 1 2 3 4 5 6 7
Cache disable	0 0 0 0 X X X X
Cache flush	1 0 X 0 X X X X
Cache normal	0 0 0 1 X X X X
Cache wait state	0 0 1 1 X X X X
Cache retry state	1 0 1 1 X X X X
Cache directory test	0 0 1 0 X X X X
Cache data array test	1 0 0 1 X X X X
	Cache functions
Disable CCUI interface	X X X X 0 0 1 X
Bypass cache	X X X X 0 1 1 X
CCUI normal operation	X X X X 0 0 0 X
	CCUI functions
DMA SP RAM init	X X X X 0 1 0 X
SCTL normal operation	0 1 0 0 0 0 0 0
Disable SCTL error action	0 1 X X 1 1 X X
	For CCUI and MCTL functions
ECC disable	X 1 1 0 1 X X X
ECC transparent	X 1 0 1 1 X X X
MCTL error wrap	0 1 1 1 1 X X 0
ECC only mode	0 1 1 1 1 X X 1
NO refresh mode	0 1 X X 1 X 1 X
Force storage errors	1 1 X X 1 0 0 0
Force storage errors	1 1 X X 1 0 1 0
Force storage errors	1 1 X X 1 1 0 0
Force storage errors	1 1 X X 1 1 1 0
Force storage errors	1 1 X X 1 1 0 1
Force storage errors	1 1 X X 1 1 1 1
	Force Y.7 at 0 Force Y.7 at 1 Force Y.7 , X.7 at 0 Force Y.7 , X.7 at 1 Force Y.7, X.7 & 1.0 at 0 Force Y.7, X.7 & 1.0 at 1

X'75'	Input: CSCW	Output: NA
Byte X, Bit 0		
1		
2		
3		
4		
5		
6		
7		
Byte 0, Bit 0	IOC CSCW bit 05) See note 1	
1	IOC CSCW bit 11) & note 2 for	
2	IOC CSCW Bit 12) these bit	
3	IOC CSCW Bit 13) decode & next	
4	IOC CSCW Bit 14) paragraph	
5	0	
6	0	
7	0	
Byte 1, Bit 0	Not used	
1	Not used	
2	Not used	
3	Not used	
4	Not used	
5	0	
6	0	
7	0	

Notes:

1. Bit 0 = 0: AIO from CAs.
Bit 0 = 1: AIO from LAs.
2. Bits 1 to 4 are: either pointer number if bit 0=0, or LAs address if bit 0=1.

X'75' Register LA/CA Addresses Decoding

Adapter Type	Byte 0 0 1 2 3 4	Adapter Number
TRA	1 0 0 0 0	01
TRA	1 0 0 0 1	02
LSS/HSS/ESS	1 0 0 1 0	03
LSS/HSS/ESS	1 0 0 1 1	04
LSS	1 0 1 0 0	09
LSS	1 0 1 0 1	10
LSS	1 0 1 1 0	11
LSS	1 0 1 1 1	12
CA	0 0 0 0 0	05
CA	0 0 0 0 1	06
CA	0 0 0 1 0	07
CA	0 0 0 1 1	08

X'76'	Input: IOC Level 1 Interrupt Request	Output: Miscellaneous Control
Byte X, Bit 0	0	Not significant
1	0	Not significant
2	0	Not significant
3	0	Not significant
4	0	Not significant
5	0	Not significant
6	0	Not significant
7	0	Not significant
Byte 0, Bit 0	IOC Address excep. I See	Reset IOC errors
1	IOC Storage protec. I Note	Not significant
2	IOC Invalid CCW I	Start branch trace mode
3	0	CCU prog. request to MOSS
4	IOC Timeout	CCU prog. response to MOSS
5	IOC Bus in parity	Not significant
6 ¹	IOC Adapter init.operation	Not significant
7 ¹	IOC MOSS init.operation	Not significant
Byte 1, Bit 0	Not used	Not used
1	Not used	Not significant
2	Not used	Not significant
3	0	Not significant
4	Not used	Not significant
5	Not used	Not significant
6 ¹	Not used	Not significant
7 ¹	Not used	Not significant

¹ = This bit does not generate a level 1 interrupt.

Note: In byte 0 or 1, if bits 4 and 5 are zero, bits 0, 1, 2, and 3 are as shown.

If bit 4 or bit 5 is one, bits 0, 1, 2, and 3 contain IOC internal status at the time of the error. (See further on input X'76' state meaning for time out or bus-in parity error.)

Input X'76' State Meaning for Time Out or Bus-in Parity

State Latch Decode	Valid Tags (See Note)	'Time out' Meanings	"Bus in parity Error" Meanings
0	08	I/O tag is OFF	No
1	10	I/O tag raised new AIO or IOH	No
2	18-11	No response to TA or channel grant	No
3	-	CCW parity error	CCW parity error
4	10	VH didn't fall after TD fall	AIO data read or channel pointer register read 2nd transfer
5	18-16 11	No response to TD for AIO data read, or IOH data read	Bus-in parity error on AIO data read, or IOH data read
6	18-16 11	No response to TD for AIO data write, or IOH data write	No
7	10	VH didn't fall after TD fall (byte boundary transfer with 'STG')	No
8	08	I/O tag is OFF, VH must rise (EOC after channel pointer updating in local store)	Channel pointer register read transfer last transfer (EOC)
9	10	VH didn't fall after 'CG' fall, AIO CCW: S/L or D/I.D or D/I.D.WR	No
A	08	I/O tag is OFF, VH must rise (last AIO transfer data read is on byte boundary)	No
B	10	No	Loading of CCW
C	18-11	No response to TD for AIO pointer initialization	Bus-in parity error AIO address sent to adapter during AIO direct operation
D	-	No	No
E	10	VH didn't fall after TD fall for AIO pointer initialization	Channel pointer register read 1st transfer
F	08	I/O tag is OFF, VH must rise (IOH end or AIO end after data exchange)	Last AIO data read (EOC or VB + M)

Note:

Tags Encode	Tags
08	VH
10	IRR
11	IRR, EOC
16	IRR, VB, M
18	IRR, VB

For details on I/O tag, refer to "Chapter 3" AIO, IOH, or PIO operation.

X'77'	Input: Adapter Level 2, 3, 4 Interrupt Requests	Output: Miscellaneous Control
Byte X, Bit 0	0	Not significant
1	0	Not significant
2	0	Not significant
3	0	Not significant
4	0	Not significant
5	0	Not significant
6	0	Not significant
7	0	Not significant
Byte 0, Bit 0	Not used	Reset IPL level 1 and not init.bit
1	Level 2 bus 1 priority	Reset CCU hard checks
2	Level 2 on bus 1	Reset MOSS panel inter.req.level 3
3	Not used	Reset MOSS diag request level 3
4	0	Reset MOSS SVC request level 3
5	0	Reset MOSS SVC response level 4
6	0	
7	0	Reset PCI level 2
Byte 1, Bit 0	Level 3 bus 1 priority	Reset MOSS inoperative level 1
1	Not used	Reset interval timer level 3
2	Level 3 on bus 1	Reset PCI level 3
3	Not used	Reset MOSS level 2 diagnostic request
4	0	Reset address compare level 1
5	0	Reset program errors
6	0	Reset PCI level 4
7	0	Reset SVC level 4

Byte 0 pertains to level 2 and byte 1 to level 3. The priority bits in byte 0 for level 2 are independent of those in byte 1 for level 3.

Notes:

1. The following description applies to either byte.

One of the priority bits in a byte will be set ON if and only if one or both of the bus interrupt bits in that byte are ON. However, the priority will be set one cycle after the interrupt bit(s) is set, therefore there is a 1-cycle window in which either or both interrupt bits can be ON without either priority bit. This window occurs at the time interrupts are sampled from the adapter bus, not necessarily at input X'77' time, but may affect the result of input X'77'.

To avoid this window, it is recommended that the program use input X'77' in any one of the following ways.

- a. Test only the priority bits in the appropriate byte, ignoring the interrupt bits. This will insure that single and simultaneous bus interrupts will be serviced in turn without the possibility of missed interrupts or ambiguity. In this case, there is no restriction on when input 77 may be performed.
- b. Test only the interrupt bits, ignoring the priority bits (in this case, the program would have to decide by other means which interrupting bus to service). There is no restriction on when input X'77' may be performed.
- c. If neither procedure above is used, the use of the input X'77' instruction is restricted, as follows: input X'77' should be performed in level 2 or level 3 only if there are no adapter interrupt(s) for that level.

If no adapter interrupts are pending, they must be serviced and an exit performed. In addition to this restriction, input X'77' should not be performed more than once in a level.

2. After the control program issues an IOH to clear an adapter interrupt, at least 22 CCU cycles must be performed before executing an exit instruction or an input X'77' or X'7E' (read adapter interrupt) instruction. This is to allow reset and re-sampling of interrupts from the adapters.

Utility X'79'	Input:	Output:
Byte X, Bit 0	0	Not significant
1	0	Not significant
2	0	Not significant
3	0	Not significant
4	0	Not significant
5	0	Not significant
6	0	Not significant
7	0	Not significant
Byte 0, Bit 0	0	Not significant
1	0	Not significant
2	0	Set program IPL request
3	0	Not significant
4	0	Remote power OFF
5	0	Inhibit program level 5C and Z latches
6	Program level 5C condition	Program level 5C latch
7	Program level 5Z condition	Program level 5Z latch
Byte 1, Bit 0	Program level 2 interrupted (1)	Not significant
1	Program level 3 interrupted (1)	Not significant
2	Program level 4 interrupted (1)	Set AIO stop mode on IOC (3)
3	Program level 5 interrupted (1)	Reset AIO stop mode on IOC (3)
4	0	Set bypass CCU check stop (2/3)
5	0	Reset bypass CCU check stop (2/3)
6	0	Scope synchro pulse 1
7	0	Scope synchro pulse 2

Notes:

1. Only one bit will be ON corresponding to the program level executing when the level 1 interrupt was taken.
2. Bypass CCU checkstop mode bit is not set by the control program. This bit is for potential use by diagnostics only.
3. When there is contention between set and reset bits, the set has priority.

High-Resolution Timer X'7A'	Input: (LS) Address Pointer	Output:
Byte X, Bit 0	0	Not significant
1	0	Not significant
2	Timer bit 0	Not significant
3	Timer bit 1	Not significant
4	Timer bit 2	Not significant
5	Timer bit 3	Not significant
6	Timer bit 4	Not significant
7	Timer bit 5	Not significant
Byte 0, Bit 0	Timer bit 6	1=Reset timer or enable count
1	Timer bit 7	0=High-resolution, 1=low resol.
2	Timer bit 8	0=Timer, 1=utilization count
3	Timer bit 9	Not significant
4	Timer bit 10	Not significant
5	Timer bit 11	Not significant
6	Timer bit 12	Not significant
7	Timer bit 13	Not significant
Byte 1, Bit 0	Timer bit 14	Not significant
1	Timer bit 15	Not significant
2	Timer bit 16	Not significant
3	Timer bit 17	Not significant
4	Timer bit 18	Not significant
5	Timer bit 19	Not significant
6	Timer bit 20	Not significant
7	Timer bit 21	Not significant

X'7B'	Input: Branch Trace (LS) Address Pointer	Output: Set PCI Level 2
Byte X, Bit 0	Branch trace address bit X.0	Not significant
1	Branch trace address bit X.1	Not significant
2	Branch trace address bit X.2	Not significant
3	Branch trace address bit X.3	Not significant
4	Branch trace address bit X.4	Not significant
5	Branch trace address bit X.5	Not significant
6	Branch trace address bit X.6	Not significant
7	Branch trace address bit X.7	Not significant
Byte 0, Bit 0	Branch trace address bit 0.0	Not significant
1	Branch trace address bit 0.1	Not significant
2	Branch trace address bit 0.2	Not significant
3	Branch trace address bit 0.3	Not significant
4	Branch trace address bit 0.4	Not significant
5	Branch trace address bit 0.5	Not significant
6	Branch trace address bit 0.6	Not significant
7	Branch trace address bit 0.7	Not significant
Byte 1, Bit 0	Branch trace address bit 1.0	Not significant
1	Branch trace address bit 1.1	Not significant
2	Branch trace address bit 1.2	Not significant
3	Branch trace address bit 1.3	Not significant
4	Branch trace address bit 1.4	Not significant
5	Branch trace address bit 1.5	Not significant
6	Branch trace address bit 1.6	Not significant
7	Branch trace address bit 1.7	Not significant

X'7C'	Input: Branch Trace (LS) Buffer Count	Output: Set PCI Level 3
Byte X, Bit 0	0	Not significant
1	0	Not significant
2	0	Not significant
3	0	Not significant
4	0	Not significant
5	0	Not significant
6	0	Not significant
7	0	Not significant
Byte 0, Bit 0		Not significant
1		Not significant
2		Not significant
3		Not significant
4		Not significant
5		Not significant
6		Not significant
7		Not significant
Byte 1, Bit 0		Not significant
1		Not significant
2		Not significant
3		Not significant
4		Not significant
5		Not significant
6		Not significant
7	Not significant	

Note: Binary indication of branch trace buffer size in number of bytes. Actual length is a multiple of 8 bytes; bits 1.5, 1.6, and 1.7 are ignored by the branch trace mechanism.

CCU Hard Errors

X'7D'	Input: CCU Hard Errors	Output: Set PCI Level 4
Byte X, Bit 0	0	Not significant
1	0	Not significant
2	0	Not significant
3	0	Not significant
4	0	Not significant
5	0	Not significant
6	0	Not significant
7	0	Not significant
Byte 0, Bit 0	POP parity error	Not significant
1	MDOR parity error	Not significant
2	MIOC parity error	Not significant
3	Storage error 1	Not significant
4	Cache/CCU error	Not significant
5	Cache/SCTL error	Not significant
6	Storage error 2	Not significant
7	Local store parity error	Not significant
Byte 1, Bit 0	Cache internal error	Not significant
1	A/B bus parity error	Not significant
2	D1 register parity error	Not significant
3	Not significant	Not significant
4	SAR parity error	Not significant
5	ROS parity error	Not significant
6	Z register parity error	Not significant
7	D2 register parity error	Not significant

Note: Byte 0, bits 3 and 6 are encoded:
If the value is 01 = interface error
If the value is 10 = SCTL internal error
If the value is 11 = unrecoverable storage error.

X'7E'	Input: Level 1 Interrupt Requests	Output: Set Interrupt Mask
Byte X, Bit 0	0	Not significant
1	0	Not significant
2	0	Not significant
3	0	Not significant
4	0	Not significant
5	0	Not significant
6	0	Not significant
7	0	Not significant
Byte 0, Bit 0	MOSS inoperative	Not significant
1	CCU hard error summary	Not significant
2	IOC-line adapter	Not significant
3	Level 5 IO error	Not significant
4	Invalid operation	Not significant
5	IOC-channel adapter	Not significant
6	Not significant	Not significant
7	IOC level 1 summary	Not significant
Byte 1, Bit 0	Address compare level 1	Not significant
1	Address exception inst.fetch	Adapter level 1 request
2	Storage protection inst.fetch	Level 2 request
3	Address exception pgm.exec.	Level 3 request
4	Storage protection pgm.exec.	Level 4 request
5	Not significant	Program level 5 execution
6	IPL level 1	Not significant
7	Not significant	Not significant

Notes:

1. For CCU hard error summary see input X'7D'.
2. For IOC level 1 see input X'76'.

When the CCU executes the input X'76' instructions, it places IOC level 1 interrupt requests into byte 0.

X'7F'	Input: CCU Level 2, 3, or 4 Interrupt Requests	Output: Reset Interrupt Mask
Byte X, Bit 0	0	Not significant
1	0	Not significant
2	0	Not significant
3	0	Not significant
4	0	Not significant
5	0	Not significant
6	0	Not significant
7	0	Not significant
Byte 0, Bit 0	PCI level 2	Not significant
1	MOSS diagnostic level 2	Not significant
2	MOSS diagnostic level 3	Not significant
3	MOSS request SVC level 4	Not significant
4	MOSS response SVC level 4	Not significant
5	0	Not significant
6	CE/Operation int.req.level 3	Not significant
7	PCI level 4	Not significant
Byte 1, Bit 0	0	Not significant
1	0	Adapter level 1 request
2	0	Level 2 request
3	0	Level 3 request
4	0	Level 4 request
5	Interval timer level 3	Program level 5 execution
6	PCI level 3	Not significant
7	SVC level 4	Not significant

Hardware Registers

Hardware registers are used to store and pass information essential to controller operation. Some of these hardware registers are available to the control program as external register addresses through the use of input and output instructions.

Instruction Address Register (IAR): See 'General Registers' above.

Lagging Address Register (LAR): The LAR is loaded from the IAR at the beginning of each instruction execution. The lagging address register is a 'came from' register. When displayed by the operator or by the program using input X'74' or MOSS indirect input X'74', it contains the address of the last instruction executed prior to the instruction that is currently being executed if any (this might not be true in case of error. Refer to *Principles of Operations Manual*. for more information).

The control program can load the contents of the LAR into a general register by executing an input X'74' instruction. The control program can then either examine the contents of the general register or display the address on the control panel by using the general register as input to the display registers.

Operation Register (OP Register): The operation register is used to hold the first 16 bits of the instruction being executed. This register can be displayed on the control panel.

Storage Address Register (SAR): The storage address register contains the storage address currently used or last used. The contents of the SAR can be displayed on the control panel.

Program Display Register 1: This register in local storage (LS address X'79') contains a parameter passed from the program running in the CCU to the program running in MOSS for eventual display as display register 1, to an operator. It can be loaded by executing an output X'71' instruction.

Program Display Register 2: This register in local storage (LS address X'7A') contains a parameter passed from the program running in the CCU to the program running in MOSS for eventual display as display register 2 to an operator. It can be loaded with data by executing an output X'72' instruction.

Operator Address/Data Value Register: This register in local storage (LS address X'71') contains a parameter passed from the program running in MOSS to the program running in the CCU when an operator wishes to express an address or data value. It can be read by executing an input X'71' instruction.

Operator Function Select Value Register (16 Bits): This register in local storage (LS address X'72') contains a parameter passed from the program running in MOSS to the program running in the CCU when an operator wishes to express a selected function value. It can be read by executing an input X'72' instruction.

Maintenance Temporary Address Register (MTAR): This register in local storage (LS address X'7E') contains the main storage address used by any operation initiated by the program running in MOSS and involving main storage.

Maintenance Temporary Data Register (MTDR): This register in local storage (LS address X'7F') contains information read out of main storage for the operations described for the maintenance temporary address register(MTAR) (see above).

CCU to and from MOSS

The CCU interconnects with the MOSS via the MOSS input and output controller (MIOC) logic located in the PUC (part of the CCU).

The MIOC enables the MOSS to:

- Read or write any register or storage location in the CCU.
- Set or reset all CCU latches and read out their status.
- Interrupt the CCU (CCU hardware errors, IPL request, and so on).

Also, the MIOC allows the CCU to interrupt the MOSS.

CCU Diagnostics

The CCU has diagnostic facilities designed to allow the program to perform test procedures on the controller hardware. The test routines can be either part of the online control program or a stand-alone control program used for testing purposes only. If these test routines are part of the online control program, the telecommunication lines and adapters not being tested are allowed to continue operating.

The following operations are available for program use:

Set and Reset the Bypass CCU Check Stop Mode: Output X'79', byte 1, bit 4 set to 1 prevents CCU hard stop and MOSS interrupt from being set due to a CCU hard check. To reset the bypass mode, the control program must execute an output X'79' instruction with byte 1, bit 5 set to 1.

However, MOSS can also issue a bypass CCU check stop or a CCU hard stop. The following table shows the resulting CCU mode.

MOSS	Program	CCU Mode Result
-	-	Normal (2)
-	Bypass	Bypass
Bypass	-	Bypass
Bypass	Bypass	Bypass
Bus stop (1)	-	Normal (2)
Bus stop (1)	Bypass	Normal (2)
Bus stop and bypass		Bypass

Notes:

1. Adapter interface check stop causes adapter interface errors to be handled as hard errors.
2. See "CCU Error Handling" and "Program Errors" on page 2-47 for more information.

Set and Reset the Level 1 Adapter Mask: Program level 1 interrupt requests caused by a check condition in an adapter (scanner or CA) can be masked by using an output X'7E', byte 1, bit 1. To unmask the level 1 requests, the control program must execute an output X'7F' (reset mask bits) with byte 1, bit 1 set to 1.

CCU Error Handling

The following are the basic principles of the CCU error handling strategy:

CCU-Detected Hardware Errors: They are high-severity errors, usually hardware failures. They stop the CCU. No retry is performed. The error indication latches are sensed by MOSS through the LSSD path.

CCU-Detected Not Hard Errors: They are low-severity errors, either program errors, or IOC bus errors, or MOSS 'interconnection' errors. They do not stop the CCU. They can be encountered during the following operations:

1. MOSS operations through the MIOC or adapter operations (AIOs) performed with the MOSS flag.
These errors are reported to MOSS only.
2. Program instructions and adapter operations (non-MOSS):
These errors are reported to the program only.

Checking the Checkers

All checkers can be checked by the LSSD scan path.

CCU Error Handling Summary

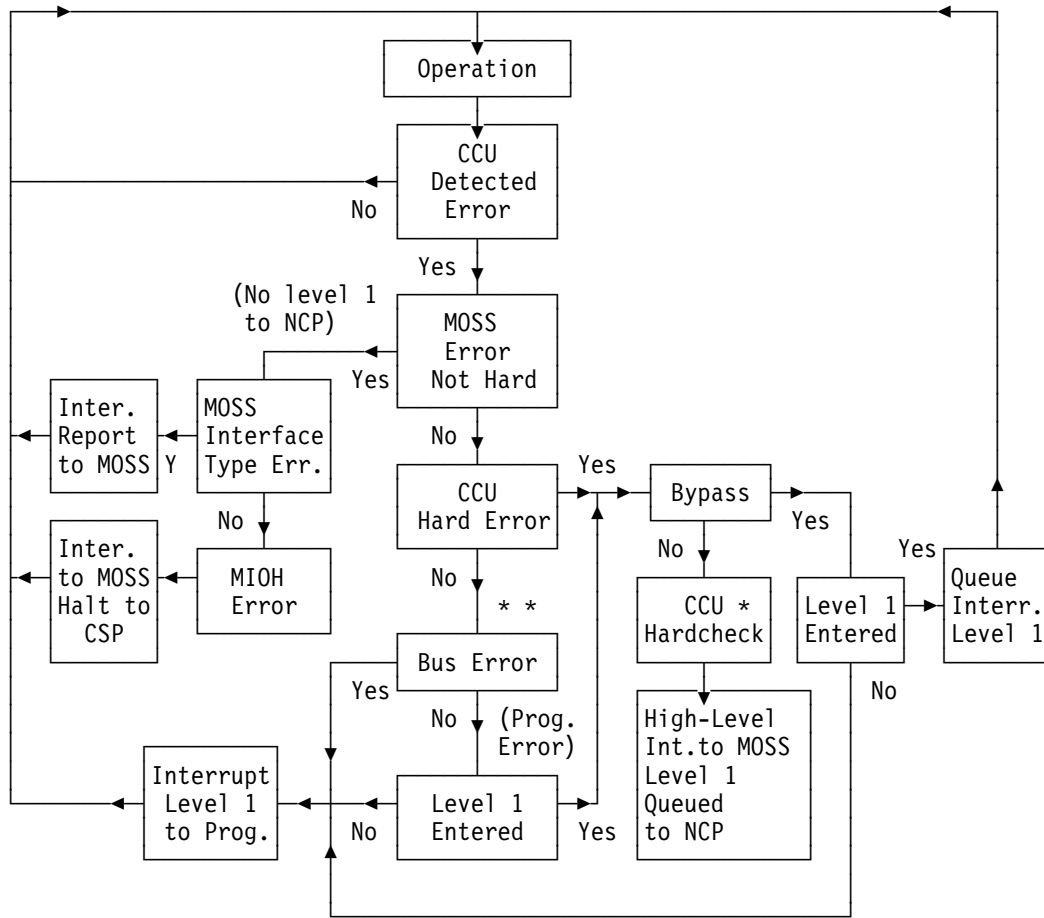

- Notes:** * CCU hard check results in stopping the program, AIOs, and branch trace.
 ** Bus error without adapter interface check stop mode.

CCU Error Detection

Hardware Errors

Control ROS Parity Error: Parity error detected on one of the CCU control word registers (latches receiving one ROS field).

MOSS Data Operand Register (MDOR) Parity Error: Parity error during a read MDOR operation on the MDOR-to-MOSS bus.

MIOC Parity Error: Parity error during MOSS write operation.

Local Storage Parity Error: Parity error detected on data bytes 0 or 1 of the local storage during a read operation. (Possible parity error on byte X is not detected.)

D1/D2 Register Parity Errors (Two Errors): Parity error detected in the IOC D register after each register setting (except when set from adapter bus which results in putting the bus in parity check).

Z Register Parity Error: Parity error detected on any byte X 0 or 1 in the Z register except during input X'7x' instruction execution.

POP Parity Error: Parity error detected in the pre-OP register (containing the pre-fetched instruction) before transferring its contents to the OP register.

SAR Parity Error: Parity error detected in the storage address register at any time.

For other parity errors, see "CCU Hard Errors" on page 2-39.

Notes:

1. At storage initialization time unrecoverable storage errors are inhibited and storage write operations are not prevented when ECC disable is set (see OUT X'74').
2. A CCU clock check is also provided. This check activates an error condition latch in the MOSS.

Handling

These errors are latched inside the CCU. A CCU hard check condition is detected, which stops the CCU, that is:

- Program stop
- AIO stop
- Hard stop
- MOSS direct operations are allowed. Indirect MOSS operations may be performed if the CCU is in bypass hard stop mode.

A high-level interrupt is sent to the MOSS.

An interrupt level 1 to the control program is queued but not executed unless in bypass check stop mode.

When the CCU is stopped the LSSD path is used by the MOSS to collect the error information from the CCU error latches through the 'scan out' line.

This error information can be made available to the operator by MOSS.

When these error latches are set by errors (not forced by diagnostics) they are unavailable to the control programs which reside in main storage.

After error information collection, MOSS may cause a re-IPL to take place.

Program Errors

Storage Protect Program Execution Error: Storage protect keys mismatch or read-only key violation during a program storage instruction.

Address Exception Program Execution Error: Program attempt to read or write uninstalled storage.

Storage Protect Instruction Fetch Error: Attempt to execute an instruction fetched from a storage area whose key did not match the program user key.

Address Exception Instruction Fetch Error: Attempt to execute an instruction fetched from an uninstalled storage location.

Level 5 I/O Error: Attempt to perform an input or output instruction in program level 5.

Invalid OP-Code: Attempt to execute an instruction with an OP-code that does not compare to any of the 53 valid OP-codes, or input, or output instruction to invalid external register addresses.

Handling

These errors result in an interrupt level 1 sent to the control program except if already in program level 1 (in this case a CCU hard check condition occurs).

Error information can be obtained by the control program using the input X'7E' instruction (see "Input Instructions" on page 2-25).

However, storage protect or address exception errors are unrecoverable in program execution (load or store instruction) because, in some cases, the next instruction will be executed before the interrupt to program level 1.

For details on DMA storage protect, see Chapter 5, "High Performance Transmission Subsystem (HPTSS)" on page 5-1.

Adapters Interconnection Errors

IOC Adapter Bus Parity Error: Parity error detected when reading the IOC bus.

IOC Time-Out Error: Erroneous timing sequence on IOC interface.

IOC Adapter CCW Error: Invalid channel control word coming from the adapter.

IOC Storage Protect Error: Storage protect violation detected during an adapter-initiated operation (AIO) write.

IOC Address Exception Error: Attempt to read or write storage not installed during an adapter-initiated operation.

Notes:

1. Parity and time-out errors can be encountered with program user (IOH, IOHI) or with MOSS user (MIOH).
2. All errors can be encountered with AIOs.
3. In adapter interface check stop mode these bus errors are handled as hard errors.

Handling

With Program User (IOH, IOHI): These errors result in an interrupt level 1 sent to the program, and a halt signal is sent to the adapter. Error information can be obtained by the control program, using the input X'7E' and input X'76' instructions.

With MOSS User (MIOH): (MOSS IOCs OP error)

These errors result in a high-level interrupt to MOSS and a halt signal is sent to the adapter. No level 1 interrupt will be issued by the LAs in this case. Error information can be obtained by MOSS, using the input X'76' instruction.

During Program AIOs: These errors result in an interrupt level 1 to the control program and a halt signal is sent to the adapter. No level 1 interrupt will be issued to the MOSS by the LAs.

Error information can be obtained by the control program, using input X'7E' and input X'76' instructions.

The adapter address will be obtained by the program, using the input X'75' instruction which allows sensing the CCW bits.

During MOSS AIOs: These errors during an adapter AIO operation for MOSS will result in a halt signal sent to the adapter. These AIOs are differentiated from the program AIOs by bit 1.0 of the CSCW which is set ON for MOSS.

A high-level interrupt is sent to MOSS, if the error occurs after the CCW is transferred.

Adapter Interface Check Stop Mode: When the CCU is in adapter interface check stop mode, that is, when MOSS has sent the adapter interface check stop bit, any IOC bus error encountered with any user will be handled like a hard error.

Notes:

1. Error detected during MOSS operations (MIOH) are not reported to the control program.
2. Error detected during control program operations (MOSS AIOs) are not reported to the MOSS.

Summary of Actions Taken During AIOs and PIOs

Event	Action In			
	AIO for Program	AIO for MOSS	IOH/IOHI	MIOH
AIO stop (by MOSS)	Mask ch.req. *	mask ch.req. *	Mask ch.req. *	Mask ch.req. *
SP/AE violation	Halt to add. level 1	Halt to add HLIR to MOSS	Level 1 (when I fetch)	Not available
Add. compare stop	Mask ch.req. *	Mask ch.req. *	Mask ch.req. *	Not available
Adapter bus error (wo add. bus check stop mode)	Halt to add level 1	Halt to add HLIR to MOSS	Halt to add level 1	Halt to add HLIR to MOSS
Hard check	Halt to add mask ch.req. *	Halt to add mask ch.req. *	Halt to add mask ch.req. *	Halt to add Mask ch.req. *

* "Mask ch.req." means "Mask channel request" for AIOs, that is, AIO stop is set.

MOSS Interconnection Type Errors

MOSS Interconnection Parity Error

- Parity error detected either on MOSS address bus or on MOSS data bus during a write operation.
- Parity error detected on MOSS address bus during a read operation.

MOSS OP Error: Moss initiates an indirect operation while the CCU busy bit is ON, meaning that CCU resources are already used for a previous MOSS indirect operation.

MOSS Address Exception Error: MOSS attempted to read or write storage which is not installed.

Handling

These errors result in a high-level interrupt to MOSS (for MOSS OP error and MOSS address exception error), or in a signal returned to MOSS through an interface line (for MOSS interface parity error).

Performance Test Points

The performance test points (TPs) (see the list on the following table), located on the PUC card, may be used to scope or to count the internal events with the appropriate tools.

Signal Name	Physical Pin Coordinate	Signal Name	Physical Pin Coordinate
+ CCU cycle pulse	A30E00	- Latched scope sync 1	A30F00
Not used	A30E10	- Latched scope sync 2	A30F10
- CCU level 1	A30E20	+ MOSS current	A30F20
- CCU level 2	A30E30	+ Stop C clock latched	A30F30
- CCU level 3	A30E40	- IOC1 IO tag	A30F40
- CCU level 4	A30E50	- IOC1 AIO/hold	A30F50
- CCU level 5	A30E60	Not used	A30F60
- Any instruction	A30E70	Not used	A30F70
+ Process ADDR compare	A30E80	Spare pin	A30F80
-IO wait	A30E90	Spare pin	A30F90

The performance test points (TPs) are located on the wiring side of the PUC card (CCU). The following figure will help in locating the test points.

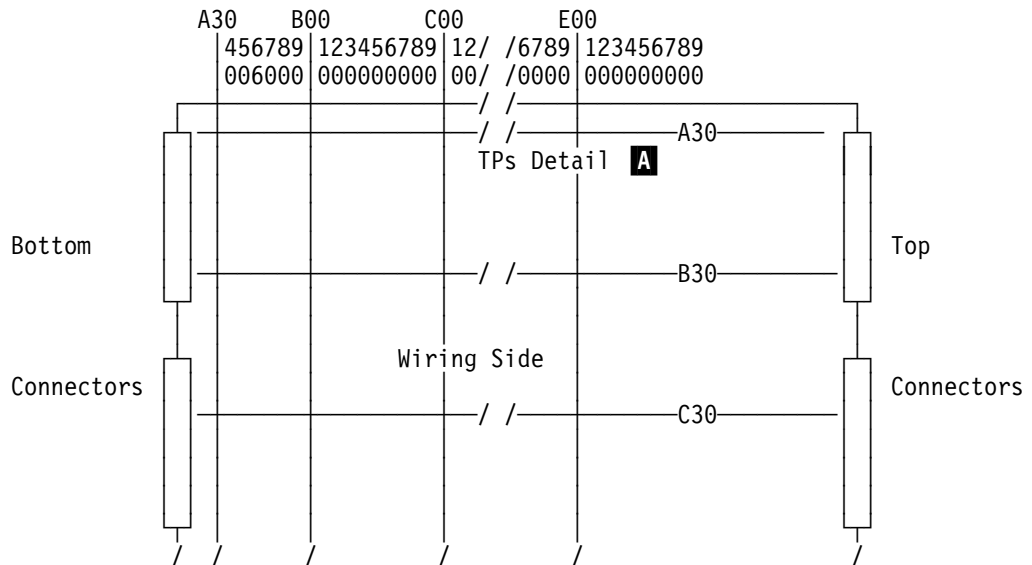

Test Points Detail **A**

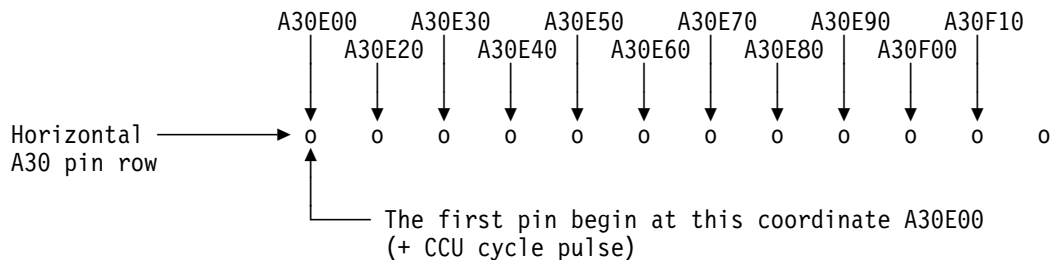

Chapter 3. Buses

The Buses in 3745 Models 130, 150, 160, and 170 Data Flow	3-2
The Buses in 3745 Model 17A Data Flow	3-3
Generalities	3-4
IOC Bus	3-4
IOC Bus Protocol	3-4
CCU-Bus Layout (Maximum Configuration)	3-5
CCU/Adapters Interconnection	3-6
DMA Bus	3-10
PIO Operation	3-15
AIO Operation	3-19
Bus Propagation Cards (BPC1/BPC2)	3-29
Configuration Rules	3-29
3746-900/3745 Attachment	3-30
Adapter Addressing	3-31
Logical Adapter Address	3-31
Physical Address Wiring	3-31
CA Addressing	3-32
Line Adapter Addressing (LSS, HSS, and ELA)	3-34
3746 Model 900 Adapter Addressing (CBC, PRC)	3-36
LIC Board Addressing	3-38
Line Addressing	3-39
Token-Ring Adapter (TRA) Addressing	3-46
Token-Ring Line Addressing	3-47
Adapter Bypass Mechanism	3-48
For Line Adapters	3-48
For Channel Adapters	3-48
Cycle Steal Grant (CSG) and Autoselection Mechanism for Model 170	3-49
IOC Bus Scoping Routine	3-53
How to Start the Routine	3-53
Adapter Selection	3-54
RACs Generated	3-55
Examples of Scoping Routine on Bus Terminator	3-58
Bus Terminator (TERMI) Connector Pin Assignments	3-60

The Buses in 3745 Models 130, 150, 160, and 170 Data Flow

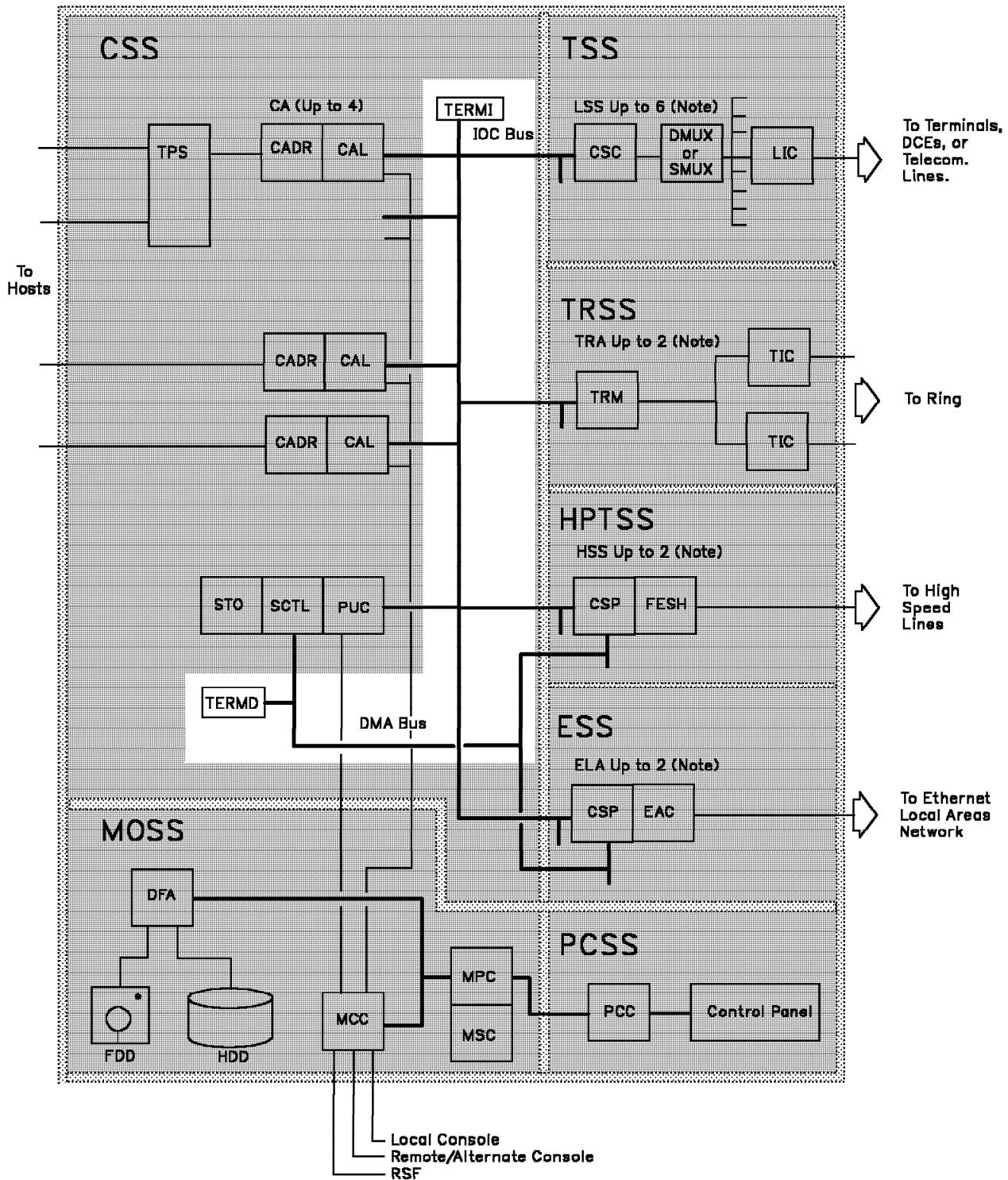

(Note) The number of LSS+HSS+ELA does not exceed 6

The Buses in 3745 Model 17A Data Flow

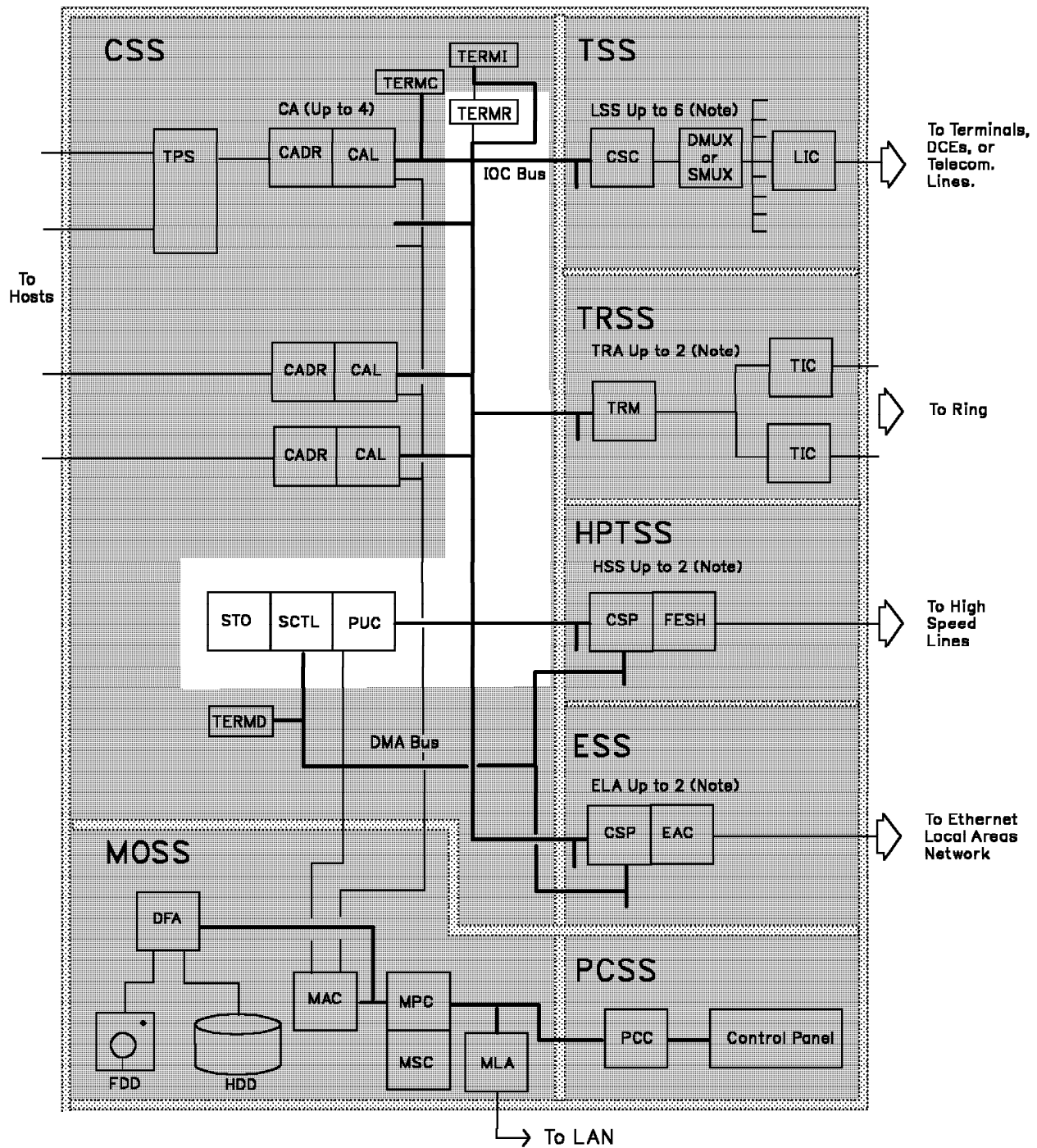

Figure 3-1. The Buses in 3745 Model 17A Data Flow. For model 17A, DMA and IOC buses are connected to the CBC in the 3746-900. This MLA card links the MOSS to the Service Processor through a LAN.

Generalities

Two types of bus connect the adapters to the CCU/SCTL.

1. IOC bus: This bus connects the CCU to the adapters.
2. DMA bus: This bus connects the SCTL card to the FESH and EAC cards. See "DMA Bus" on page 3-10.

IOC Bus

Data, address, and control information exchanges take place between the work registers and adapters attached to the IOC bus.

The IOC logic operates differently depending on whether the program initiates an operation (PIO), or the adapter initiates it (AIO).

In both operations, the A (address) and D (data) registers of the data flow controlled by the IOC logic act as buffers between the CCU(s) and the adapters (CAs and LAs).

The IOC bus carries interrupt requests from the adapters (levels 1, 2, and 3) when not busy with PIO or AIO operations.

IOC Bus Protocol

Read PIO example

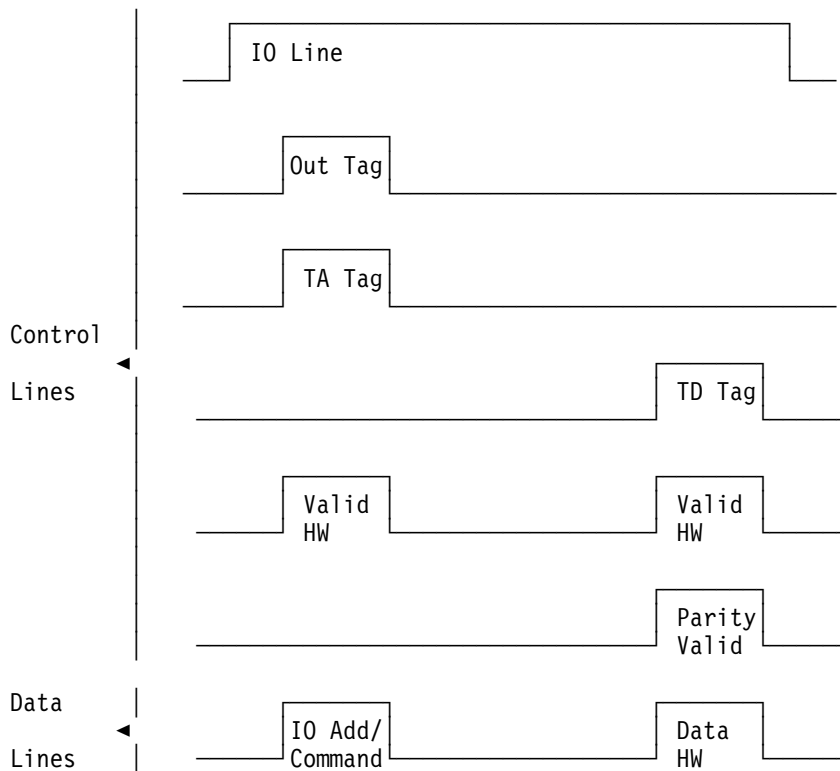

CCU-Bus Layout (Maximum Configuration)

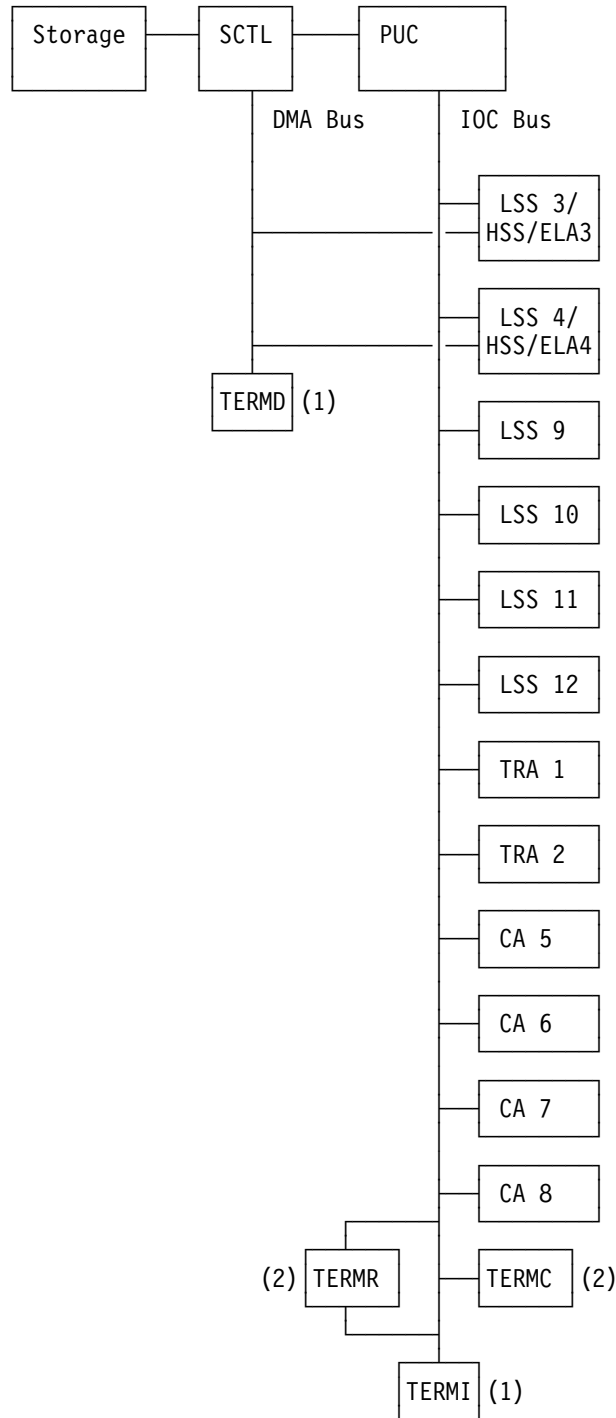

(1) = DMA and IOC buses are connected to the CBC in the 3746-900 (if present) for model 17A.

(2) = Only on 3745 Model 17A.

Figure 3-2. CCU-Bus Layout

CCU/Adapters Interconnection

Each interconnection consists of 18 bidirectional lines, (two data bytes plus two parity bits) and 16 tag and control lines.

For details on line function, see Figure 3-3.

For details on bus layout, see Figure 3-2 on page 3-5.

CCU Bus Line Function

Line Function	Abbr	CCU	CA	LA
Address/Command Tag (1)	TA	x	.	.
Data Tag (1)	TD	x	.	.
Interrupt Req. Removed (1)	IRR	.	x	x
CS Req. High (1)	CSRH	.	.	x
CS Req. Low (1)	CSRL	.	x	.
CS Grant High (1)	CSGH	x	.	.
CS Grant Low (1)	CSGL	x	.	.
Input/Output (1)	I/O	x	.	.
Halt (1)	HLT	x	.	.
Out (1)	R/W	x	.	.
Valid Byte (1)	VB	.	x	x
Valid Halfword (1)	VH	.	x	x
End of Chain (1)	EOC	.	x	x
Modifier (1)	M	.	x	x
Parity Valid (1)	PV	.	x	x
CA IPL Detect (1)	CAIPL	.	x	.
Reset Tag (See Note 1)	RST	.	.	.
Data Byte 0 (9) OUT	DB0	x	.	.
IN	DB0	.	x	x
Data Byte 1 (9) OUT	DB1	x	.	.
IN	DB1	.	x	x
Scan Int (See Note 2)	SCI	.	.	x

Legend:

(): The contents of the parentheses indicate the number of wires in line function

x : Signal generated

. : Indicates where the signal arrives

Notes:

1. Reset line is activated directly from the MOSS.
2. Sent directly to MOSS (MCC card).

Figure 3-3. CCU-Bus Line Function

The following is a short description of each of the lines in the summary table above.

Address/Command Tag (TA): The 'TA' line is activated by the CCU to indicate that the adapter address is in data byte 0 and the command is in data byte 1.

Data Tag (TD): The 'TD' line is activated by the CCU to indicate that the data bus contains write data or that the CCU is ready to receive read data while the 'I/O' line is active.

When the 'I/O' line is not active, the 'TD' line is activated by the CCU to indicate that it is permissible to change the state of any interrupt request on the data bus.

Interrupt Request Removed (IRR): The 'IRR' line is activated by any adapter that has removed its interrupt request from the data bus. Each adapter should activate 'IRR' in response to the 'I/O' line being activated and, of course, remove its interrupt request from the data bus.

Each adapter should allow 'IRR' to change to the inactive level when the 'I/O' line is inactive.

When all the adapters have allowed 'IRR' to drop, this common 'IRR' line going inactive indicates to the CCU that all adapters have placed their interrupt requests, if any, on the data bus and that the CCU may now sample for interrupts.

Cycle Steal Request High (CSRH): A scanner activates 'CSRH' whenever it wishes to start an AIO operation.

The scanner keeps 'CSRH' active until it receives 'CSGH' (Cycle Steal Grant High).

Cycle Steal Request Low (CSRL): A channel adapter activates CSRL whenever it wishes to start an AIO operation.

The channel adapter keeps 'CSRL' active until it receives 'CSGL' (Cycle Steal Grant Low).

Cycle Steal Grant High (CSGH): The CCU activates 'CSGH' in response to 'CSRH' for the purpose of selecting a scanner for an AIO operation, and receiving a 'CSCW' from the selected scanner. 'CSGH' will be deactivated by the CCU when 'valid halfword' is received from the scanner.

Cycle Steal Grant Low (CSGL): The CCU activates 'CSGL' in response to 'CSRL' for the purpose of selecting a channel adapter for an AIO operation, and receiving a 'CSCW' from the selected channel adapter. 'CSGL' will be deactivated by the CCU when 'valid halfword' is received from the channel adapter.

Input/Output (I/O): The 'I/O' line is activated by the CCU to indicate either that an I/O operation is about to start on the IOC bus, or that one is in progress.

For any I/O operation, 'I/O' is the first line activated and the last one deactivated.

When the 'I/O' line is active, all adapters should remove any interrupt requests on the data bus until the I/O is deactivated.

Halt (HLT): The CCU activates the 'halt' line to indicate to the selected adapter that the CCU has detected an error condition associated with the current operation. The CCU will activate the 'halt' line after 'TA', 'CSGH', or 'CSGL' has been deactivated. The CCU will deactivate the 'halt' line when it deactivates the 'I/O' line. The selected adapter will terminate the current operation and set a check bit active in its status register.

Out (R/W): The CCU activates the 'out' line, while the 'I/O' line is active, to indicate that the direction of information on the data bus is outbound from the CCU. The CCU deactivates the 'Out' line to indicate that the direction of information on the data bus is inbound to the CCU.

Valid Byte (VB): A selected adapter will activate the 'valid byte' line during an AIO operation to indicate a byte transfer instead of a halfword transfer. The valid byte of information will be data bus byte 1.

Valid Halfword (VH): In some places the term 'valid' is used in place of 'valid halfword'. A selected adapter will activate the 'valid halfword' line in response to the activation of the 'TA', 'TD', 'CSGH', or 'CSGL' line from the CCU. 'Valid halfword' line active indicates that the adapter has either placed information on the data bus or has received information from the data bus. It also indicates that the CCU may deactivate its control line.

All adapters will activate 'valid halfword' when the CCU deactivates the 'I/O' line, and deactivate 'valid halfword' when the CCU activates the 'I/O' line.

The CCU will proceed with an IO operation after all adapters have deactivated 'valid halfword'. A selected adapter will activate the 'end of chain' line instead of 'valid halfword' for the last halfword transfer of an AIO operation.

End of Chain (EOC) 'End of chain' active indicates that the AIO operation should be concluded and that the adapter has either placed information on the data bus or has received information from the data bus.

Modifier (M): A selected adapter will activate the 'modifier' line with 'valid byte' line for the last byte transfer of a AIO operation.

'Modifier' line active at this time indicates that the AIO operation should be concluded.

Parity Valid (PV): A selected adapter will activate 'parity valid' to indicate to the CCU that it wishes to have parity checking of data inbound to the CCU.

If 'parity valid' is active and bad parity is detected by the CCU, the CCU will activate the 'halt' line.

If 'parity valid' is deactivated and bad parity is detected by the CCU, the parity is corrected, the data is stored, and a status bit is set.

CA IPL Detect (CAIPL): A CA adapter will activate this line when it detects a "WRITE IPL" command on the host interface. When the CCU receives this signal it will raise a Level 1 interrupt to MOSS.

Reset (RST): The MOSS may activate the 'reset' line at any time to initialize all adapters. This initialization will cause all adapters to immediately terminate current operations, go to a ready state, and prepare to respond to PIO commands.

Data bus bytes 0 and 1: The data bus is halfword wide with 18 bidirectional lines. Each of the two bytes (0 and 1) contains 8 bits plus a parity bit (0-7,P).

Information is transferred between the CCU and the adapters in either direction when the 'I/O' line is active.

Four bits of the bus are used for an additional function when the 'I/O' line is deactivated, as follows:

- Byte 0 bit 1 = LAs Level 2 interrupt request to CCU.
- Byte 0 bit 5 = CAs Level 1 interrupt request to CCU.
- Byte 1 bit 0 = CAs Level 3 interrupt request to CCU.
- Byte 1 bit 5 = LAs Level 1 interrupt request to CCU.

The adapters activate their interrupt requests to the CCU using these paths, but only when the 'I/O' line is inactive.

The CCU will sample the data bus for interrupts after activating the 'TD' line, while the 'I/O' line is inactive.

Scanner Interrupt (Scan Int): Interrupt level 4 generated by the line adapter to the MOSS (MPC).

Physical Interconnection

The physical interconnection is made by board wiring.

See Figure 3-2 on page 3-5.

DMA Bus

This bus is used to transfer data from/to CCU storage to/from the high-speed adapters (FESH cards) and Ethernet LAN adapters (EAC cards).

This DMA bus is routed from the SCTL card to the FESH/EAC card(s).

See Figure 3-4 for details.

Physical Interconnection

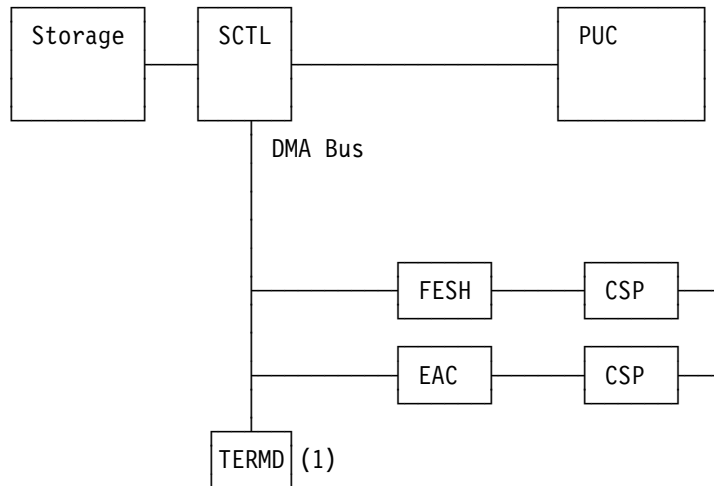
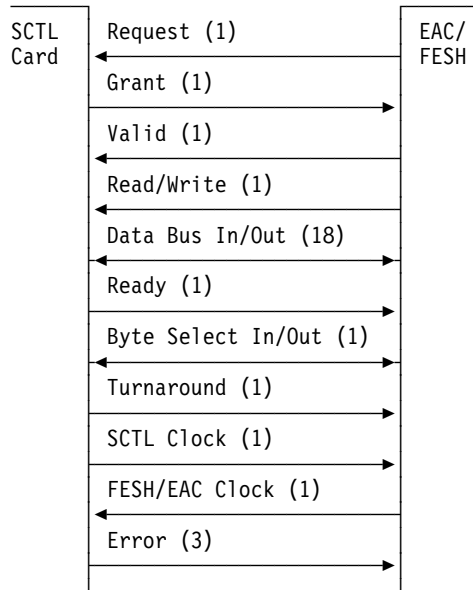

Figure 3-4. DMA Bus Physical Interconnection

(1) = DMA buses are connected to the CBC in the 3746-900 (if present) for model 17A.

Interconnection Layout



(): The figure in parentheses indicates the number of wires in the line function.

Figure 3-5. DMA Bus Interconnection Layout

DMA-to-SCTL Bus Line Function

Line Function	SCTL	EAC/ FESH
Request (1)	.	x
Grant (1)	x	.
Valid (1)	.	x
Read/Write (1)	.	x
Data Bus (18) Out	x	.
In	.	x
Ready (1)	x	.
Byte Select (1) Out	x	.
In	.	x
Turnaround (1)	x	.
SCTL Clock (1)	x	.
FESH/EAC Clock (1)	.	x
Error (3)	x	.

Legend:

(): The figure in parentheses indicates the number of wires in the line function.
 x : Signal from.

Figure 3-6. DMA Bus Line Function

The following is a short description of each of the lines in the preceding summary tables.

Request: Each request indicates that a FESH/EAC requests a DMA service (such as a Write or Read data transfer). Write means that storage will be written. Read means that storage data will be sent to the adapter.

Grant: Each grant indicates an answer to a request.

Valid: Indicates that the grant has been taken into account by the adapter and that the DMA data transfer can start.

Read/Write: Indicates the direction of the DMA data transfer.

Data bus: 18 bidirectional lines. Used to transfer the CCU address and burst length from the selected adapter, and to support the data transfers.

Ready: It is an envelope of the actual data transfer, (if the ready bit is ON there is a data transfer).

Byte Select: One bidirectional line. Indicates that only one byte is transferred in the last halfword data transfer.

Turnaround: Indicates a read data transfer.

SCTL Clock: Synchronizes the DMA bus operations.

FESH/EAC Clock: It consists in the SCTL clock gated by the valid tag in the FESH/EAC.

Errors: Used to report errors to the adapter.

See Chapter 5, "High Performance Transmission Subsystem (HPTSS)" on page 5-1 for details.

DMA Bus During Read Operation

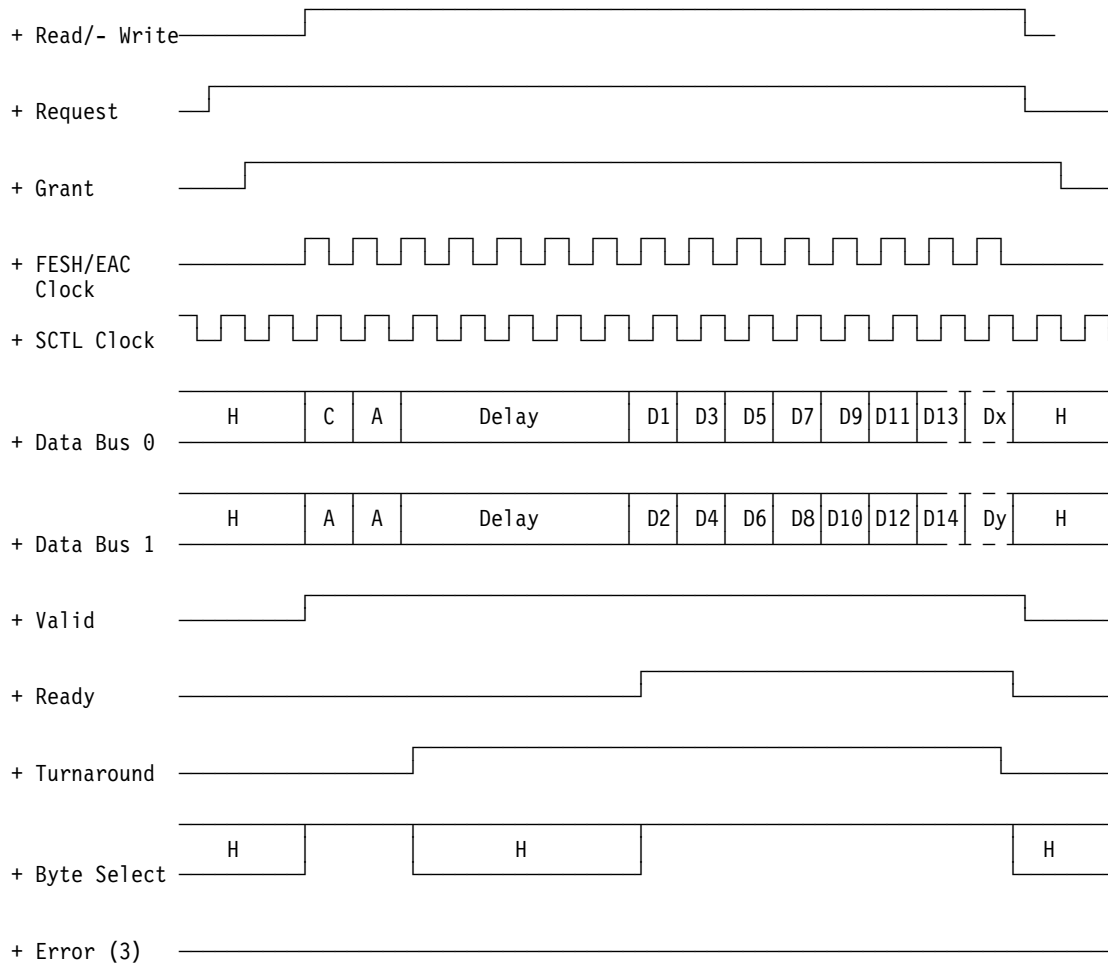

A = Address
 C = Count
 D = Data
 H = High-impedance driver 3 states
 Delay = Delay to transfer data from storage

DMA Bus During Write Operation

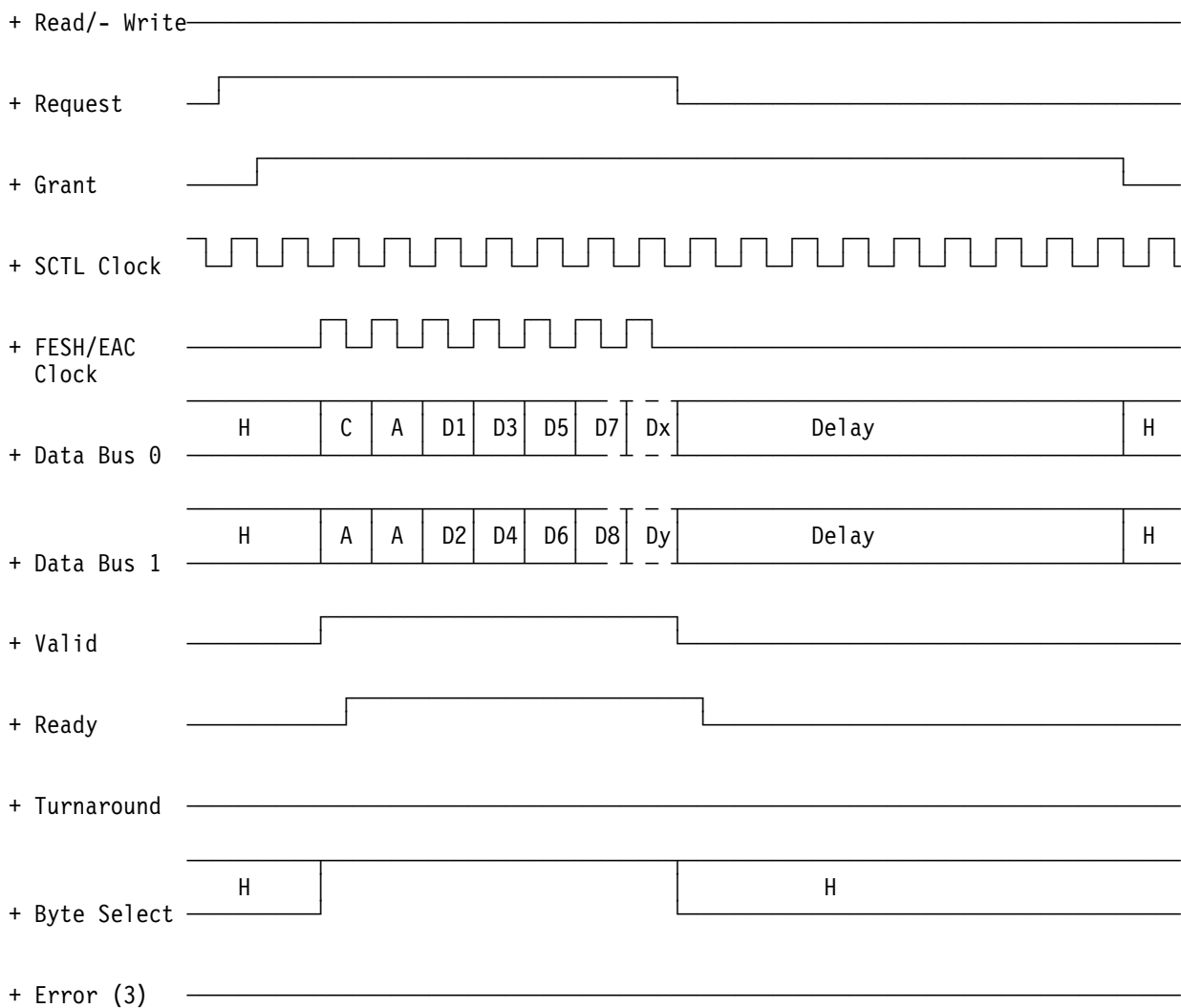

A = Address
 C = Count
 D = Data
 H = High-impedance driver 3 states
 Delay = Delay to transfer data to storage

PIO Operation

PIO Operation Sequence

A PIO operation to control a channel or an LA operation may be started either by the control program in the CCU, or by the microcode in the MOSS.

PIO Initiated by the CCU

During such an operation two halfwords (address, command, and data) are exchanged with a selected adapter.

A PIO operation has four steps:

1. IOH or IOHI instruction decode
2. IOC initialization
3. Adapter addressing and selection
4. Data transfer:
 - Write = from CCU
 - Read = to CCU

At step 1:

- Instruction code 50 = IOH with R1 and R2.
- Instruction code 70 = IOHI with R1 and the second halfword of the instruction whose contents go into the D register.

PIO Initiated by the MOSS

MIOH/MIOHI instructions are equivalent to IOH/IOHI instructions except that:

1. The MOSS initiates the operation.
2. R2 contents are found at the LS address given by the LSAR at TA time.
3. The MDOR receives or sends at data TD time instead of R1.

PIO Operation Sequence (Initialization)

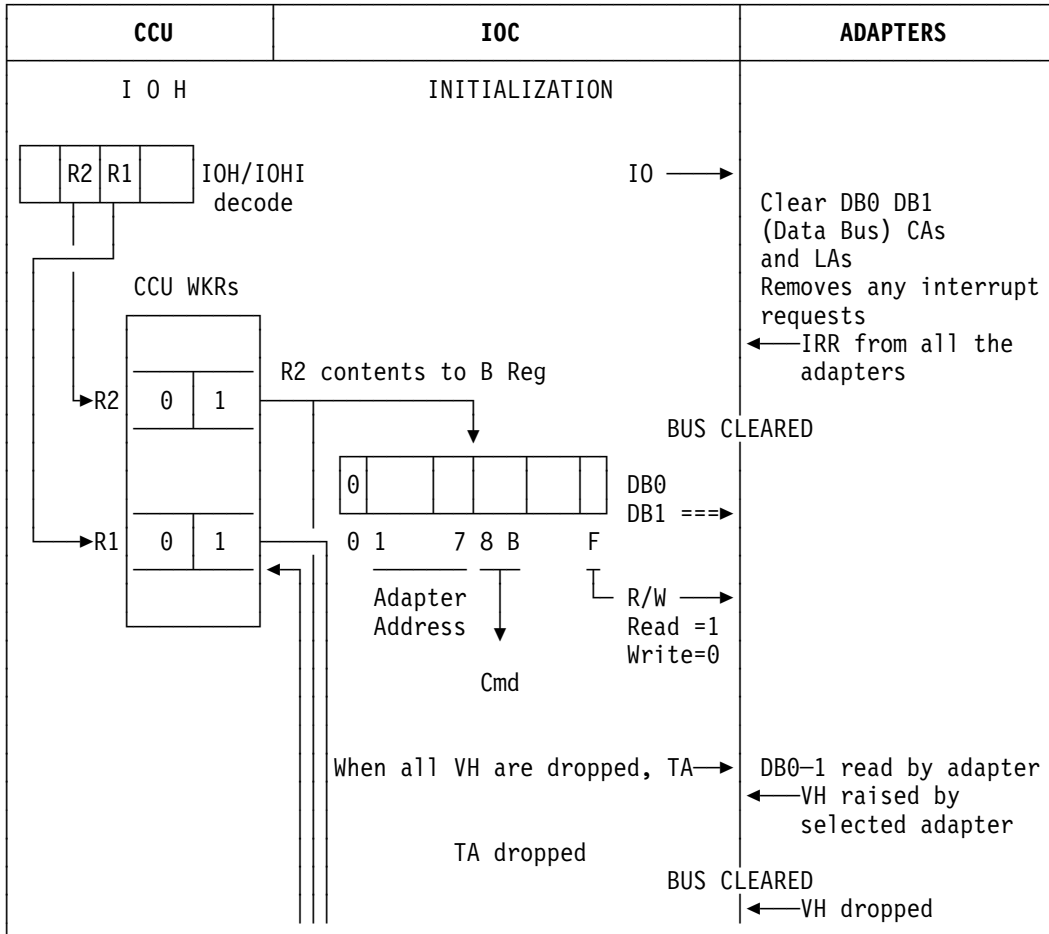

R2 = Address field
R1 = Data field

PIO Operation Sequence (Data Transfer)

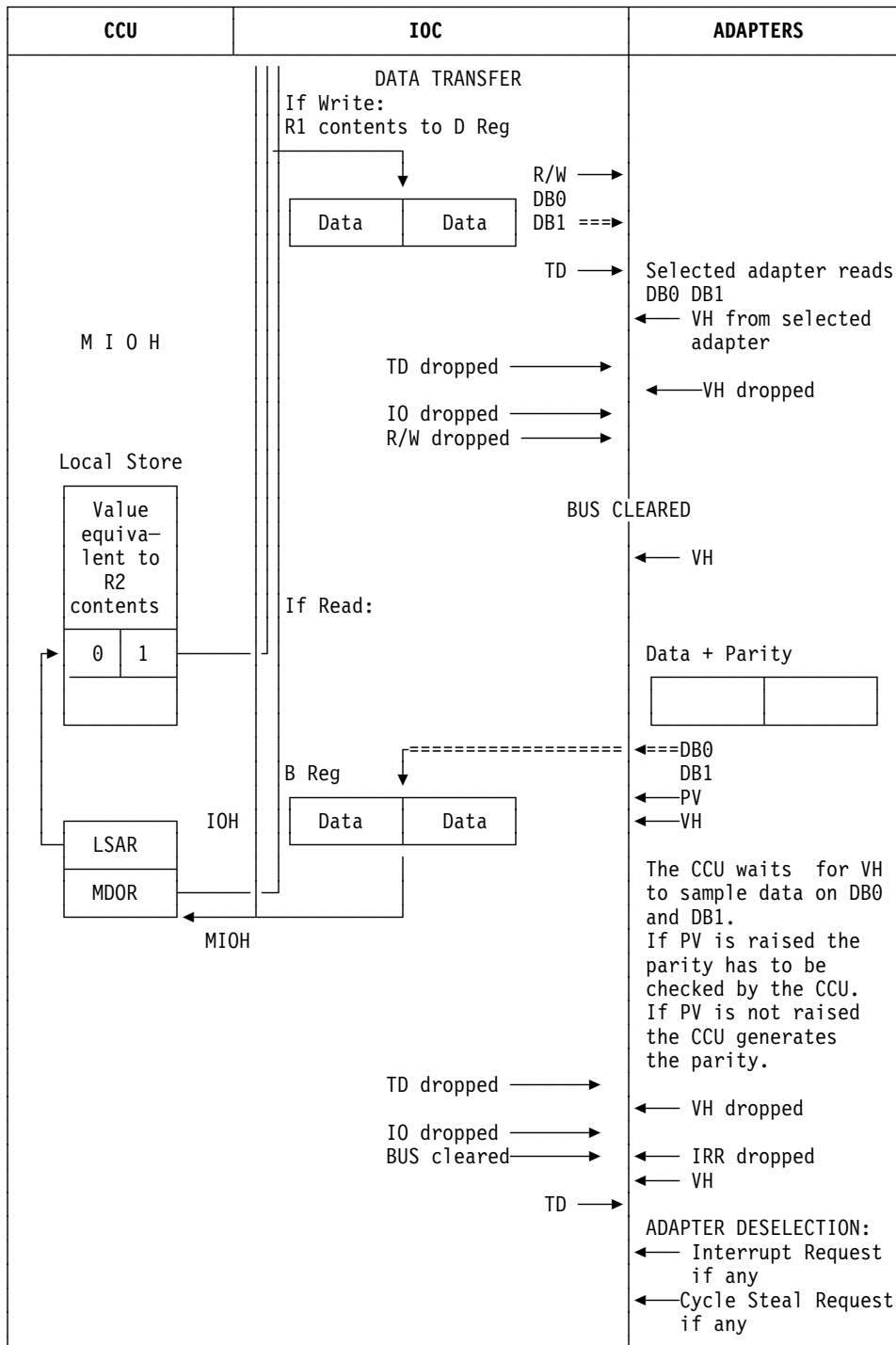

PIO Read (Halfword Adapter)

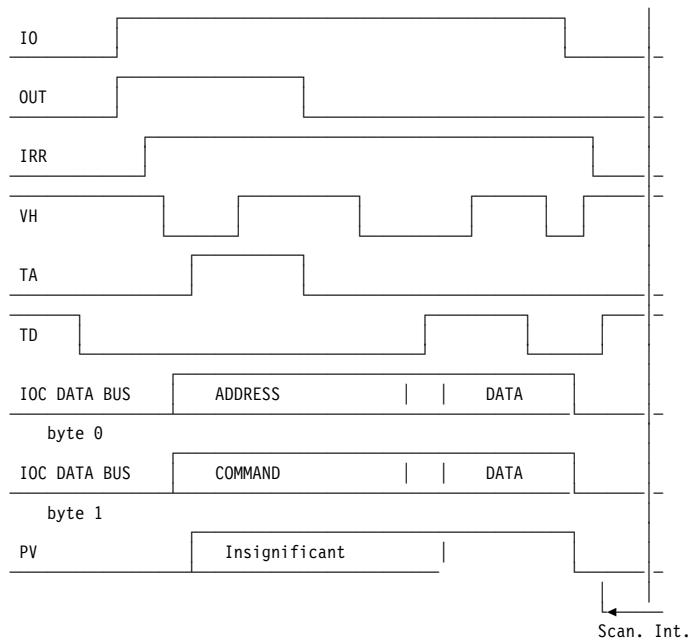

PIO Write (Halfword Adapter)

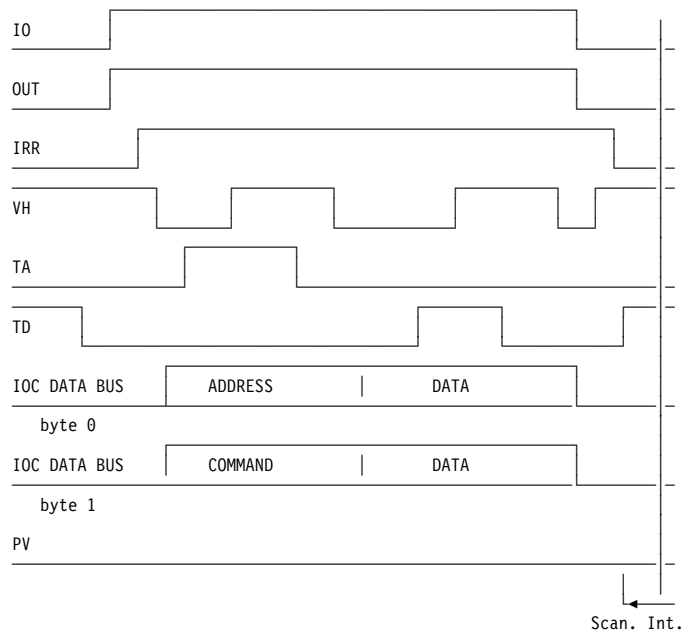

Note: Line explanation is given starting on page 3-7.

AIO Operation

AIO Operation (Cycle Stealing)

During such an operation, several units of data are exchanged between CCU and adapter storage without CP intervention. The maximum burst of data transferred is 256 bytes.

A selected LA provides the storage addresses at which the data bytes are to be stored. For this purpose, a pointer is shared by all LAs cycle steal control word (CSCW).

This information is first placed in the adapter registers by the control program, using the IOH/IOHI instructions in PIO mode.

A selected channel adapter uses its dedicated pointer which was first loaded by the control program.

AIO Operation Sequence (Initialization)

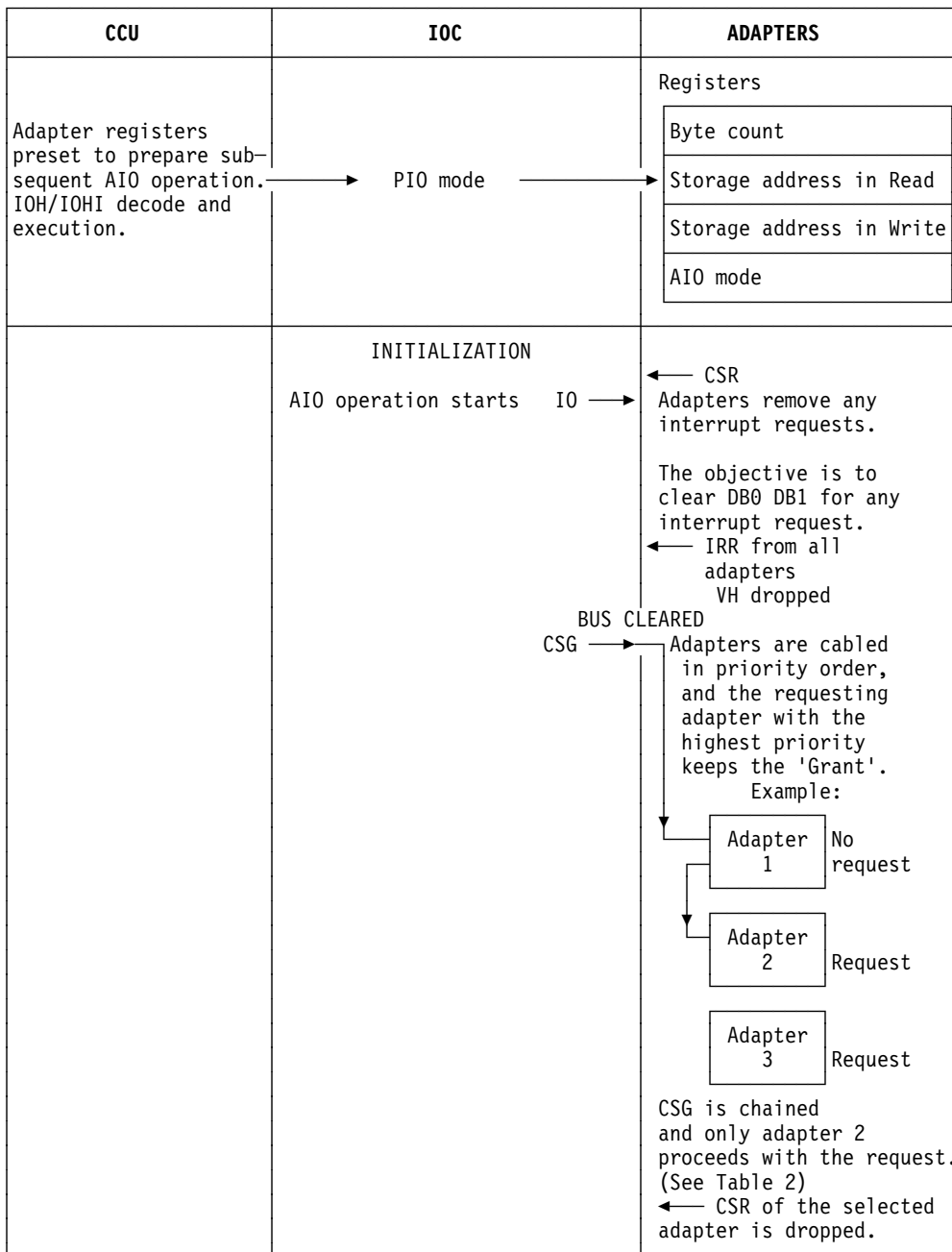

Table 1

AIO Operation Sequence (CSCW Transfer)

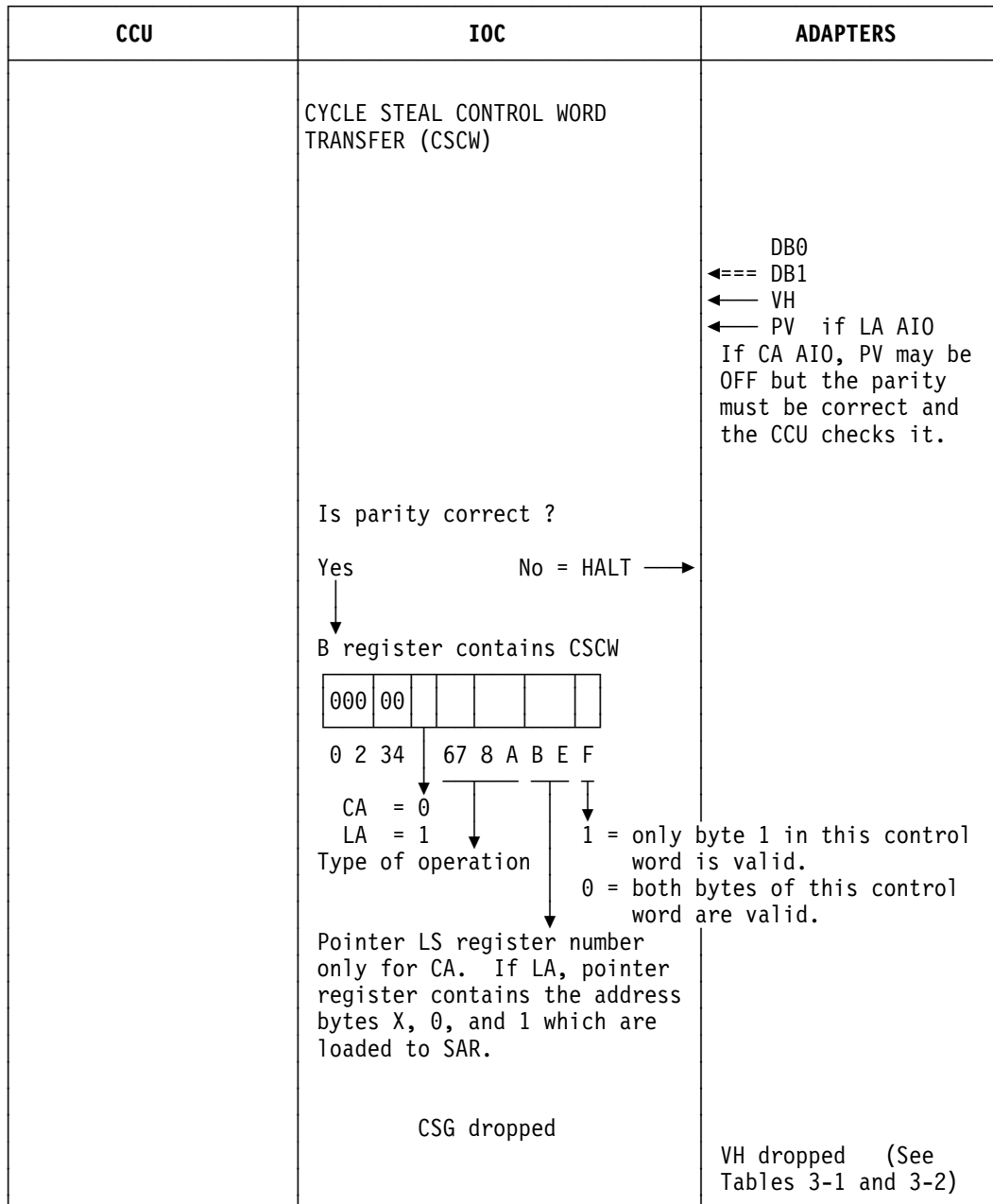

Table 2

AIO Operation Sequence for CA (Storage Address Transfer)

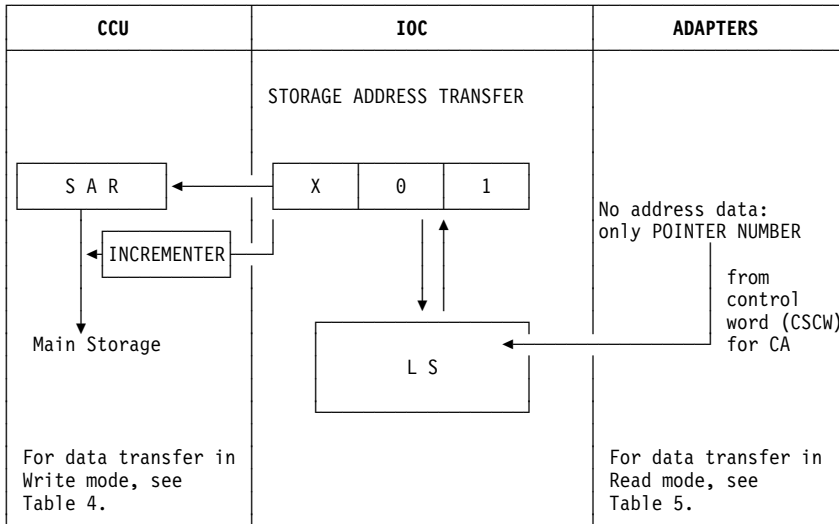

Table 3-1

AIO Operation Sequence for LA (Storage Address Transfer)

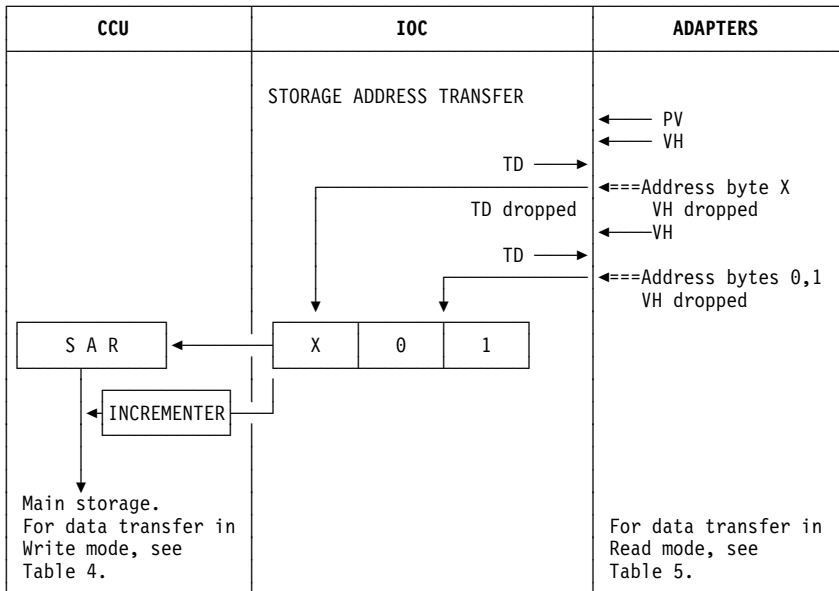

Table 3-2

AIO Operation Sequence (Data Transfer in Write)

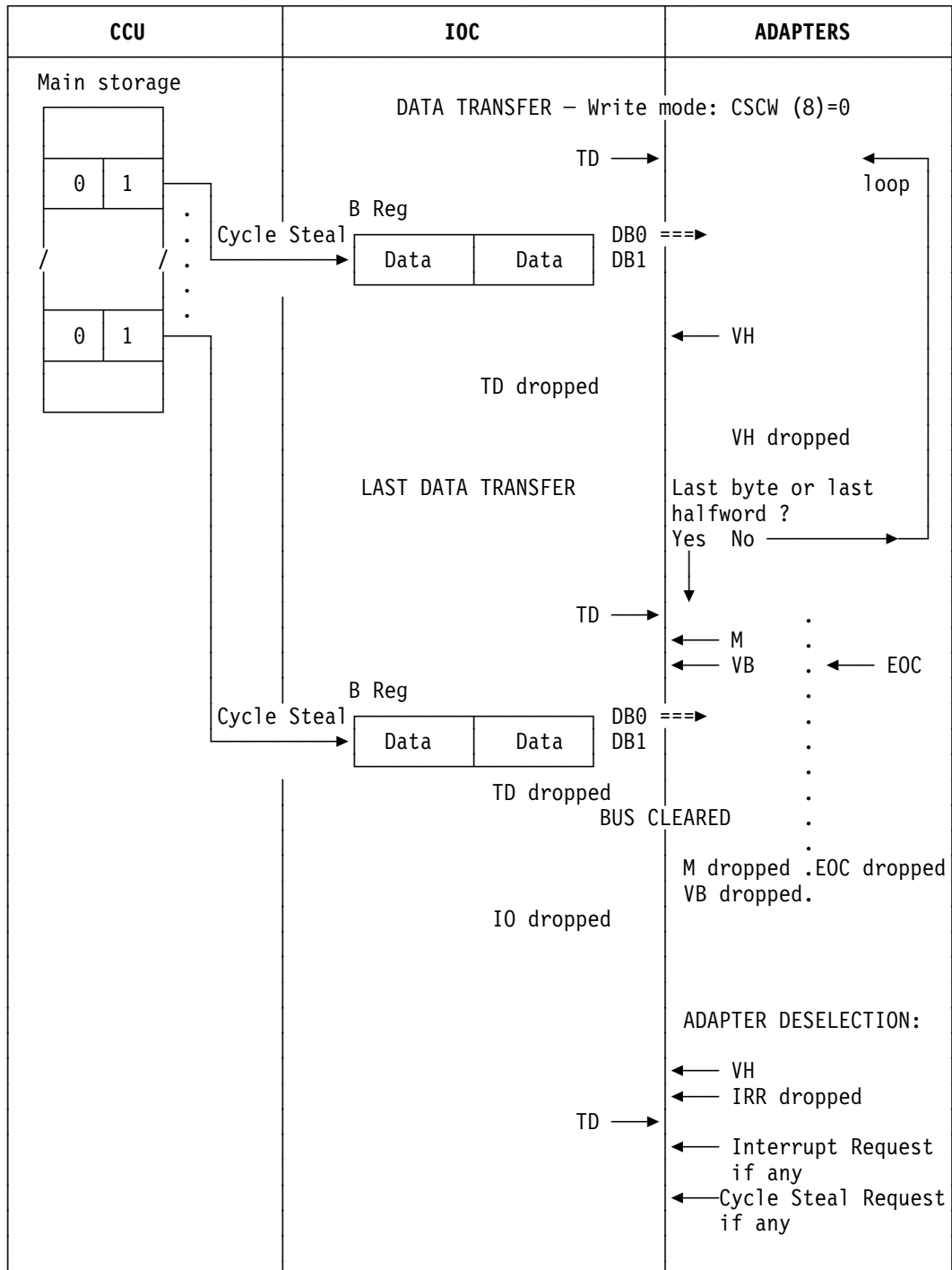

Table 4

AIO Operation Sequence (Data Transfer in Read)

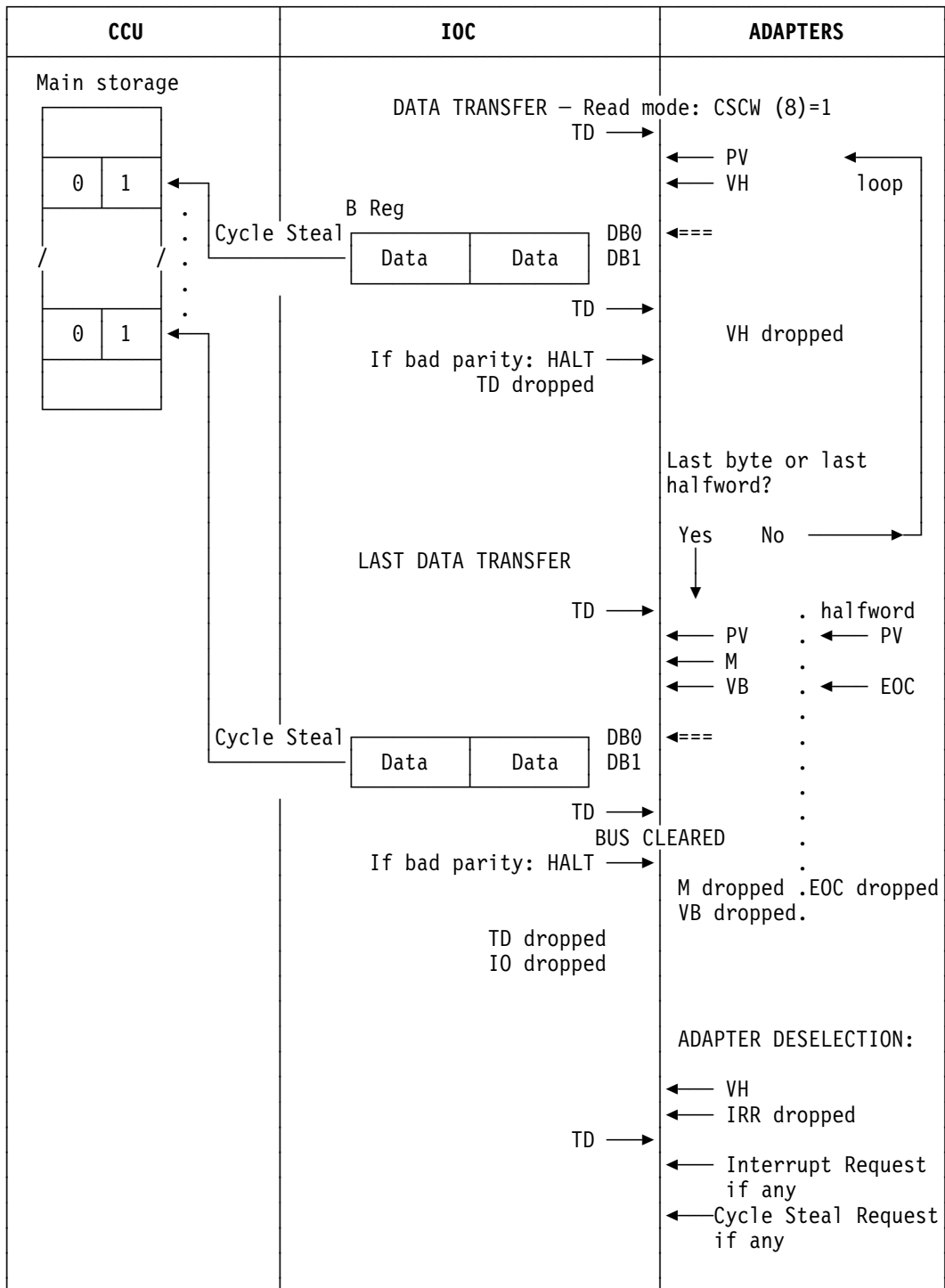
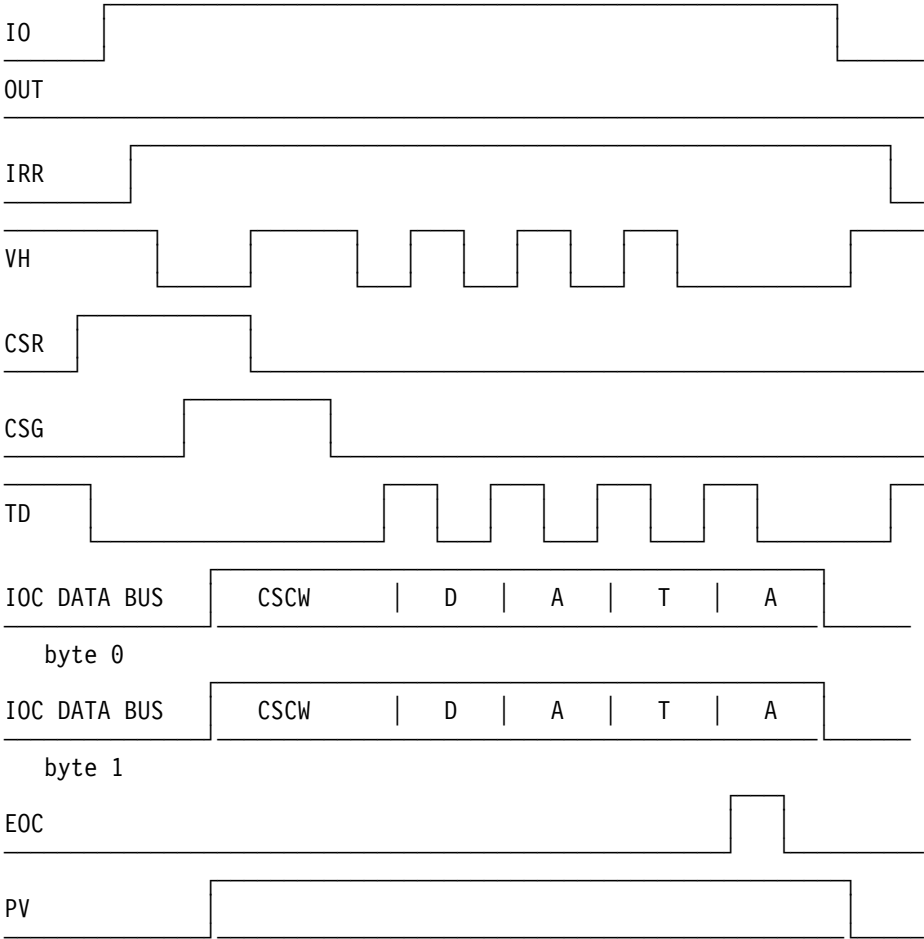

Table 5

AIO CA Read Indirect Operation (8-Byte Transfer)



Note: The last data (byte) is in bytes 0 and 1 (same data in bytes 0 and 1 during the inbound operation (VB+M tag)).

AIO CA Write Indirect Operation (7-Byte Transfer)

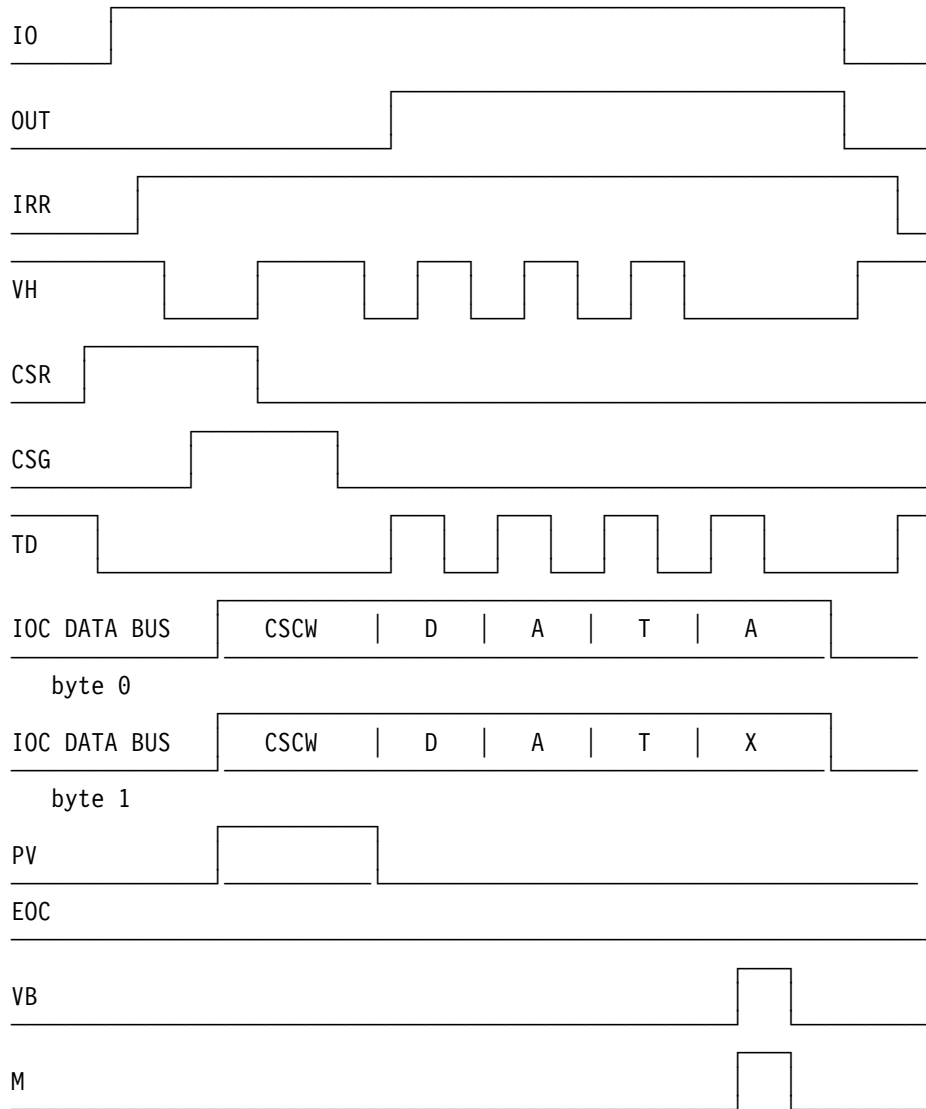

Note: The last data (byte) is in byte 0 during the outbound operation (VB+M tag).

AIO Direct/Indirect LA/TRA Read (16-Byte Transfer)

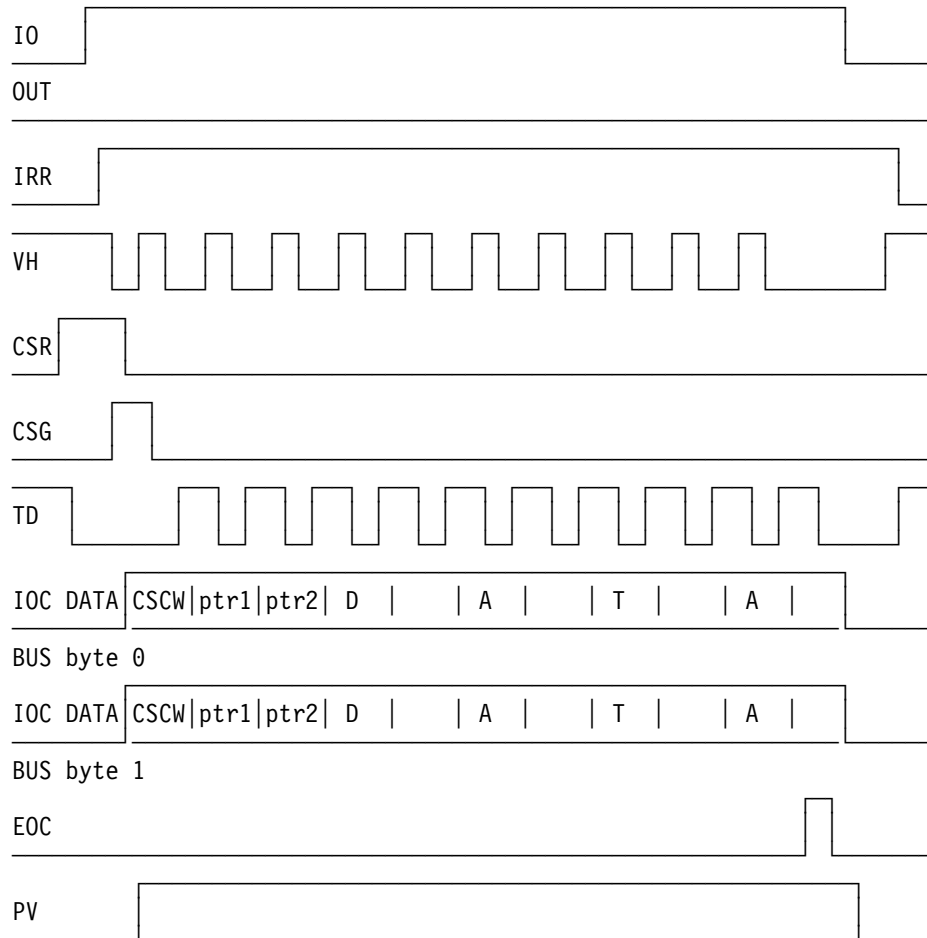

Note: The last data (byte) is in byte 1 during the read operation (VB+M tag).

AIO Direct/Indirect LA/TRA Write (16-Byte Transfer)

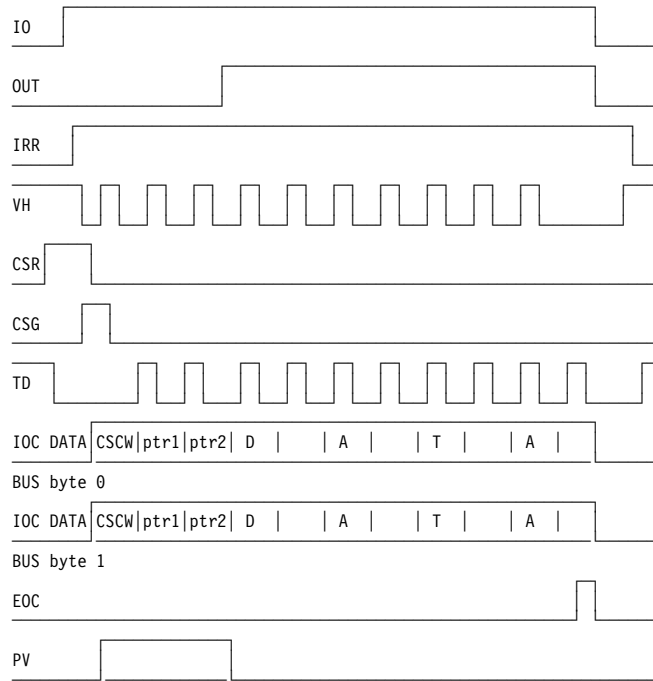

AIO TRA Read Direct Operation (2-Byte Transfer)

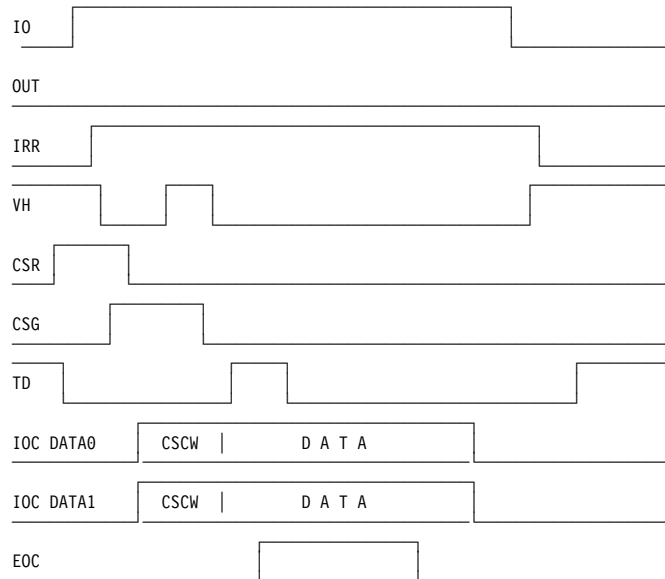

Bus Propagation Cards (BPC1/BPC2)

Configuration Rules

The bus propagation cards type 1 or type 2 (BPC1/BPC2) are installed on basic board 01G-A1 according to the 3745 model and its configuration.

3745 Model 130

- If TPS, one BPC1 is required in positions A4 and E4 instead of a CAL card.
- CSP/TRM cards:
 - If no TRA is installed:
No BPC1 or BPC2 installed
 - If one TRA is installed:
One BPC1 is required in position Q4.
One BPC1 is required in positions R4 and T4, if no CSP is installed.
One BPC2 is required in position P4.
 - If two TRAs are installed:
One BPC1 is required in position Q4.
One BPC1 is required in positions R4 and T4, if no CSP is installed.

3745 Model 150

One BPC1 is required in position T4, if no CSP is installed.

3745 Models 170 and 17A

- If TPS, one BPC1 is required in positions A4 and E4 instead of a CAL card.
- CSC/CSP cards:
 - If no TRA is installed:
 - If no CSC is installed in position Q4:
No BPC1 or BPC2 installed
 - If a CSC is installed in position Q4:
One BPC1 is required in positions R4 and T4, if no CSC or CSP are installed in these positions.
 - If a TRA is installed:
One BPC1 is required in the free positions of the CSC and CSP cards.

If a 3746-900 is connected to the 17A:

- One BPC1 is required in free position of CSC, CSP, and FESH (position M4 to U4).
- One BPC2 is required in free position of TRM (position L2).

3746-900/3745 Attachment

From an attachment point of view, the CBC is a 3745 line adapter which is attached to IOC and DMA buses.

The CBC is connected to the IOC and DMA buses from the 3745 basic board.

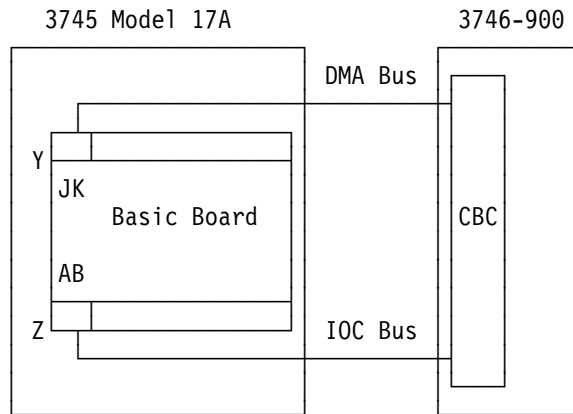

Figure 3-7. 3746 Model 900 Attachment to 3745

Adapter Addressing

Logical Adapter Address

A logical address is composed of:

- Type address
- Adapter group
- Slot.

The address is valid at IOH/MIOH command time, in PIO mode. This command is generated by the control program or the MOSS.

- The type address defines the kind of adapter (LA or CA) addressed by the control program, at TA time (and TD time for the CA) of the IOH.
- The adapter group defines the group of two adapters (LA or CA) on the IOC bus contained in the 3745.
- The slot gives the position of the adapter in the adapter group on the IOC bus.

Physical Address Wiring

The logical address sent on the IOC bus at TA time is compared by each adapter with its proper physical address.

- The type address part is provided by the logic of the adapter card.
- The slot and the adapter group part, (the bit of lowest weight), are imbedded in the printed circuit of the board.
- The adapter group part, (the remaining bit(s) of higher weight), is provided by the board.

The physical address of each adapter is provided by the following:

- WU is the IOC bus connection: IOC1 (WU = 0).
- WS is the slot wire: Position 0 or 1 in the group.
- WG1, WG2, WG3 are the group address wires.

CA Addressing

PIO Mode

The number of CAs to address is four.

The IOH OUT '07' is the only one which selects a CA. The definition of the IOH/MIOH bit pattern is:

- Byte 0, bit 0 of TA time is the IOC connection:
0 = IOC1
- Byte 0, bits 1-4 is the type address: Code = 0 0 0 1 for all CAs
- Byte 0, bits 5-7 and byte 1, bits 0-7 is the command code = 0 0 0 0 1 1 1 x 0 x x
- Byte 1, bit 4 indicates the origin :
0 = Control program (IOH)
1 = MOSS (MIOH)
- The remaining part of the address is contained in the TD field. Only the MIOH command '07' is able to select a channel adapter with the following convention:
 - Byte 0, bit 2 is equal to 1 to select a CA indicated by byte 0, bits 4 to 6.
 - Byte 0, bits 4 and 5 is the group address:
0 0 = CA Group 1
0 1 = CA Group 2
 - Byte 0, bit 6 is the slot address:
0 = Slot 1
1 = Slot 2

Note: In case of TPS, the B interface uses the slots of the following CA, part of the same CA group. The address of the CA replaced by the B interface is lost.

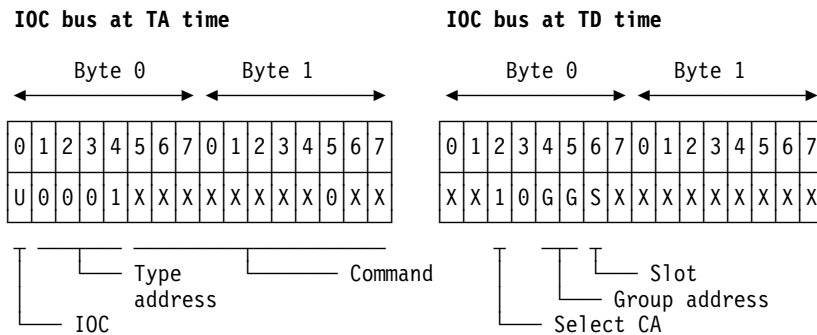

	GG = 00		GG = 01	
	S=0	S=1	S=0	S=1
IOC1 U = 0	CA 05	CA 06	CA 07	CA 08

Channel Adapter Addresses

CA	IOC bus at TA time							IOC bus at TD time																
	0	1	2	3	4	5	6	7	0	1	2	3	4	5	6	7	0	1	2	3	4	5	6	7
	U	0	0	0	1	0	0	0	0	1	1	1	0	0	0	0	0	0	1	0	G	G	S	0
05	0	0	0	0	1	0	0	0	0	1	1	1	0	0	0	0			1		0	0	0	
06	0	0	0	0	1	0	0	0	0	1	1	1	0	0	0	0			1		0	0	1	
07	0	0	0	0	1	0	0	0	0	1	1	1	0	0	0	0			1		0	1	0	
08	0	0	0	0	1	0	0	0	0	1	1	1	0	0	0	0			1		0	1	1	

MOSS Screen CA Address Display: As an example, address 0800 for CA 5A displayed on the MOSS screen is composed as follows:

```

0 8 0 0
| |
| |
v
xxxx 000x = Byte 0 at TD Time,
    . Bits 4-5 (GG) = 00 and
    . Bit 6 (S) = 0
v
0000 1xxx = Byte 0 at TA Time,
    . Bit 0 (U) = 0 and
    . Bits 1-4 (Type Address) = 0001
  
```

Line Adapter Addressing (LSS, HSS, and ELA)

PIO Mode

The number of LSS to address is six (LA3-4 and LA9-12).

Two high-speed or Ethernet lines can be installed in the system at line adapter addresses: LA 3 and LA 4.

See Figure 3-2 on page 3-5

The HSS or ELA is addressed like the LSS.

The LA address is defined at TA time of the IOH.
The line addresses for this LA are given at TD time.

The LA address is given at TA time of the IOH.

- Byte 0, bit 0 is the IOC connection:
0 = IOC1
- Byte 0, bits 1-4 is the type address and slot indicator.
Three type addresses, 0 0 1 0, 0 1 0 0, and 0 1 1 0 are recognized by the line adapters.

Type address 0 1 1 0 has the meaning of command broadcast to all LAs.

Bits 2 and 3 also have a meaning for the slot identification:

Bits 2-3 = 01 indicates slot 1 in a group address of the IOC bus.
Bits 2-3 = 10 indicates slot 2 in a group address of the IOC bus.
Bits 2-3 = 11 broadcast to all LAs.

- Byte 0, bits 5-7 is the group address. The group address identifies a pair of scanners. Three group addresses are used:

0 0 1 = Group address 2
0 1 0 = Group address 3
0 1 1 = Group address 4

IOC bus at TA time

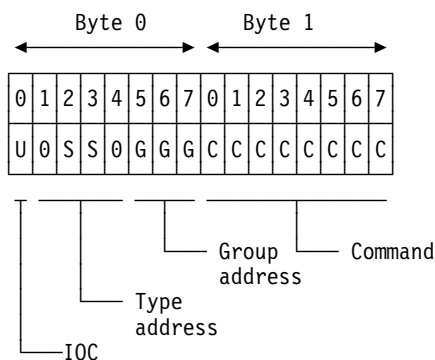

	G=001	G=010	G=011			
	SS	SS	SS	SS	SS	SS
	=	=	=	=	=	=
	01	10	01	10	01	10
IOC1	LA	LA	LA	LA	LA	LA
U=0	03	04	09	10	11	12

IOC bus at TA time
Byte 0



LA	0	1	2	3	4	5	6	7	Hex
	U	S	S	S	G	G	G		
03	0	0	0	1	0	0	0	1	11
04	0	0	1	0	0	0	0	1	21
09	0	0	0	1	0	0	1	0	12
10	0	0	1	0	0	0	1	0	22
11	0	0	0	1	0	0	1	1	13
12	0	0	1	0	0	0	1	1	23

MOSS Screen LA Address Display: As an example, address 12 for LA 9 displayed on the MOSS screen is composed as follows:

1 2



0001 0010 = Byte 0 at TA Time,
 . Bit 0 (U) = 0,
 . Bits 2-3 (SS) = 01, and
 . Bits 5-7 (GGG) = 010

3746 Model 900 Adapter Addressing (CBC, PRC)

PIO Mode

The number of adapters to address is 11 processors (PRC) and one controller bus couplers (CBC).

The address is defined at TA time of the IOH.

- Byte 0, bit 0 is the IOC connection:
0 = IOC1
1 = IOC2
- Byte 0, bits 1-2 = 11, instruction for 3746-900.
- Byte 0, bits 3-7 indicates the adapter address.

IOC bus at TA time

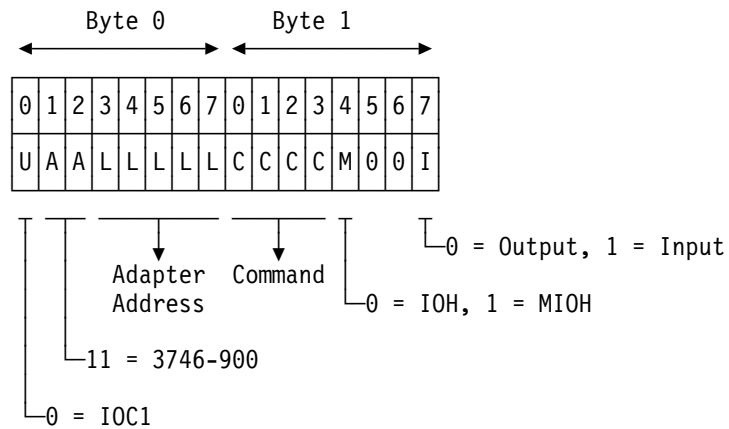

I/O Addressing

3746-900 Enclosure Location	Type of Adap.	0	1	2	3	4	5	6	7	Hex
		U	A	A	L	L	L	L	L	
07G-A1 F	CBS	0	1	1	0	0	0	1	0	62
07G-A1 H	PRC	0	1	1	0	0	0	1	1	63
07G-A1 K	PRC	0	1	1	0	0	1	0	0	64
07G-A1 M	PRC	0	1	1	0	0	1	0	1	65
07G-A1 P	PRC	0	1	1	0	0	1	1	0	66
07E-A1 D	PRC	0	1	1	0	0	1	1	1	67
07E-A1 F	PRC	0	1	1	0	1	0	0	0	68
07E-A1 H	PRC	0	1	1	0	1	0	0	1	69
07E-A1 K	PRC	0	1	1	0	1	0	1	0	6A
07E-A1 M	PRC	0	1	1	0	1	0	1	1	6B
07E-A1 P	PRC	0	1	1	0	1	1	0	0	6C
07N-A1 E	CBC1	0	1	1	1	1	1	1	0	7E

For more details on 3746-900 see, *3746 Model 900 Hardware Maintenance Reference*, online documentation.

LIC Board Addressing

The LIC board address is set with a seven-position switch located at the A1 position of the LIC board.

For location, see page YZ038 or YZ039.

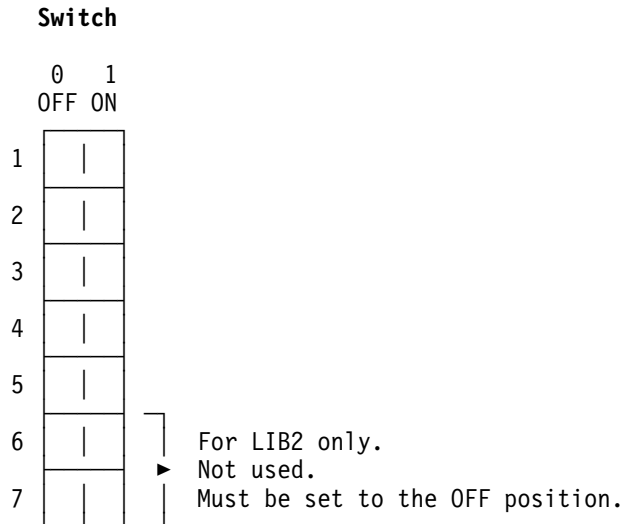

Switch Position for LIB1/3 Type (LICs 1-4)

Board Location	Switch				
	1	2	3	4	5
01M-A1	1	0	0	0	0
01M-A2	0	0	0	0	0
01L-A2	0	0	0	1	0

Switch Position for LIB2 Type (LICs 5-6)

Board Location	Switch						
	1	2	3	4	5	6	7
01L-A1	1	1	0	0	0	0	0
01L-A2	0	1	0	0	0	0	0

Figure 3-8. LIC Board Addressing Switch Position

Line Addressing

The line address used by the control program is composed of the LA address, previously defined, and of the LIC/PORT address given at TD time of the IOH using byte 1, bits 2 to 7:

Line Numbering

Depending on the configuration, two cases of line numbering are possible:

1. The floating LIC board 01L-A2 is LIB1 type (LICs type 1-4).

Possibility of 96 lines, LICs type 1-4 and 16, lines LICs type 5-6 numbered as follows:

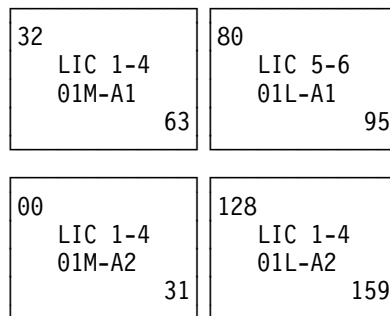

2. The floating LIC board 01L-A2 is LIB2 type (LICs type 5-6)

Possibility of 64 lines, LICs type 1-4 and 32 lines, LICs type 5-6 numbered as follows:

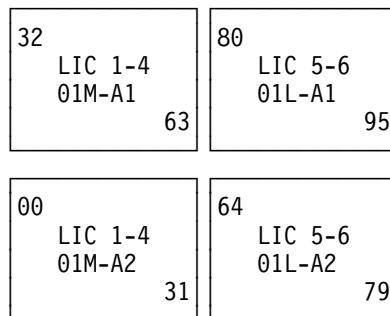

LIC1 LIC3 LIC4A and LIC4B Addressing

IOC bus at TD time

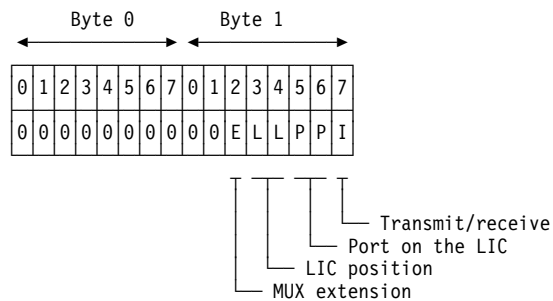

- Byte 1, bit 2 identifies part 1 or 2 in the LIC board (MUX extension).
 - Bit 2 = 0: the scanner controls part 1 in the LIC board
 - Bit 2 = 1: the scanner controls part 2 in the LIC board.
 - Byte 1, bits 3-4 indicates the LIC position in part 1 or 2.
 - 00 = First LIC in part 1 or 2
 - 01 = Second LIC in part 1 or 2
 - 10 = Third LIC in part 1 or 2
 - 11 = Fourth LIC in part 1 or 2
 - Byte 1, bits 5-6 indicates the port of the LIC.
 - 00 = First port
 - 01 = Second port
 - 10 = Third port
 - 11 = Fourth port
- LIC Type 1 and LIC Type 4A have four ports.
 LIC type 3 and LIC type 4B have only one port.
- Byte 1, bit 7 indicates the transmit or receive address.
 - When bit 7 = 1: receive address.
 - When bit 7 = 0: transmit address.

		LIC Position								
		1	2	3	4	5	6	7	8	
D M U X	00	04	08	12	16	20	24	28	PP = 00	
	01	05	09	13	17	21	25	29	PP = 01	
	02	06	10	14	18	22	26	30	PP = 10	
	03	07	11	15	19	23	27	31	PP = 11	
		LL=00	LL=01	LL=10	LL=11	LL=00	LL=01	LL=10	LL=11	
		Part 1, E = 0				Part 2, E = 1				

TSS Line Addressing for LICs 1-4

During Transmit Operation

Line	Byte 1							Hex
	0	0	E	L	L	P	I	
00	0	0	0	0	0	0	0	00
01	0	0	0	0	0	0	1	02
02	0	0	0	0	0	1	0	04
03	0	0	0	0	0	1	1	06
04	0	0	0	0	1	0	0	08
05	0	0	0	0	1	0	1	0A
06	0	0	0	0	1	1	0	0C
07	0	0	0	0	1	1	1	0E
08	0	0	0	1	0	0	0	10
09	0	0	0	1	0	0	1	12
10	0	0	0	1	0	1	0	14
11	0	0	0	1	0	1	1	16
12	0	0	0	1	1	0	0	18
13	0	0	0	1	1	0	1	1A
14	0	0	0	1	1	1	0	1C
15	0	0	0	1	1	1	1	1E
16	0	0	1	0	0	0	0	20
17	0	0	1	0	0	0	1	22
18	0	0	1	0	0	1	0	24
19	0	0	1	0	0	1	1	26
20	0	0	1	0	1	0	0	28
21	0	0	1	0	1	0	1	2A
22	0	0	1	0	1	1	0	2C
23	0	0	1	0	1	1	1	2E
24	0	0	1	1	0	0	0	30
25	0	0	1	1	0	0	1	32
26	0	0	1	1	0	1	0	34
27	0	0	1	1	0	1	1	36
28	0	0	1	1	1	0	0	38
29	0	0	1	1	1	0	1	3A
30	0	0	1	1	1	1	0	3C
31	0	0	1	1	1	1	1	3E

During Receive Operation

Line	Byte 1							Hex
	0	0	E	L	L	P	I	
00	0	0	0	0	0	0	1	01
01	0	0	0	0	0	0	1	03
02	0	0	0	0	0	1	0	05
03	0	0	0	0	0	1	1	07
04	0	0	0	0	1	0	0	09
05	0	0	0	0	1	0	1	0C
06	0	0	0	0	1	1	0	0D
07	0	0	0	0	1	1	1	0F
08	0	0	0	1	0	0	0	11
09	0	0	0	1	0	0	1	13
10	0	0	0	1	0	1	0	15
11	0	0	0	1	0	1	1	17
12	0	0	0	1	1	0	0	19
13	0	0	0	1	1	0	1	1B
14	0	0	0	1	1	1	0	1D
15	0	0	0	1	1	1	1	1F
16	0	0	1	0	0	0	0	21
17	0	0	1	0	0	0	1	23
18	0	0	1	0	0	1	0	25
19	0	0	1	0	0	1	1	27
20	0	0	1	0	1	0	0	29
21	0	0	1	0	1	0	1	2B
22	0	0	1	0	1	1	0	2B
23	0	0	1	0	1	1	1	2F
24	0	0	1	1	0	0	0	31
25	0	0	1	1	0	0	1	33
26	0	0	1	1	0	1	0	35
27	0	0	1	1	0	1	1	37
28	0	0	1	1	1	0	0	39
29	0	0	1	1	1	0	1	3B
30	0	0	1	1	1	1	0	3D
31	0	0	1	1	1	1	1	3F

LIC5 and LIC6 Addressing

IOC bus at TD time

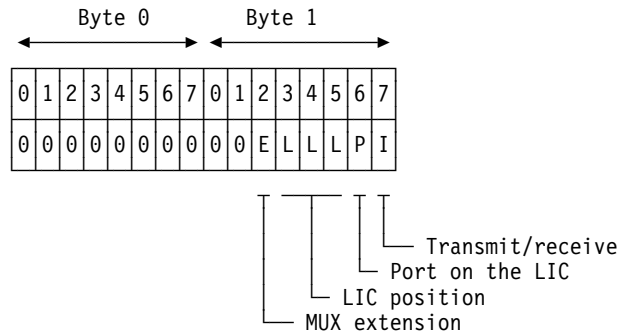

- Byte 1, bit 2 identifies the LIC board in the LIC unit.
 - Bit 2 = 0: the scanner controls the lower board in the LIC unit.
 - Bit 2 = 1: the scanner controls the upper board in the LIC unit.
- Byte 1, bits 3-5 indicates the LIC position in the LIC board.
 - 000 = LIC position 1
 - 001 = LIC position 2
 - 010 = LIC position 3
 - 011 = LIC position 4
 - 100 = LIC position 5
 - 101 = LIC position 6
 - 110 = LIC position 7
 - 111 = LIC position 8
- Byte 1, bit 6 indicates the port of the LIC.
 - 0 = First port
 - 1 = Second port

LIC type 5 has two ports.
 LIC type 6 has only one port.
- Byte 1, bit 7 indicates the transmit or receive address.
 - When bit 7 = 1: receive address.
 - When bit 7 = 0: transmit address.

Port Position for LIC Type 5 and LIC Type 6 at 9.6 and 19.2 kbps

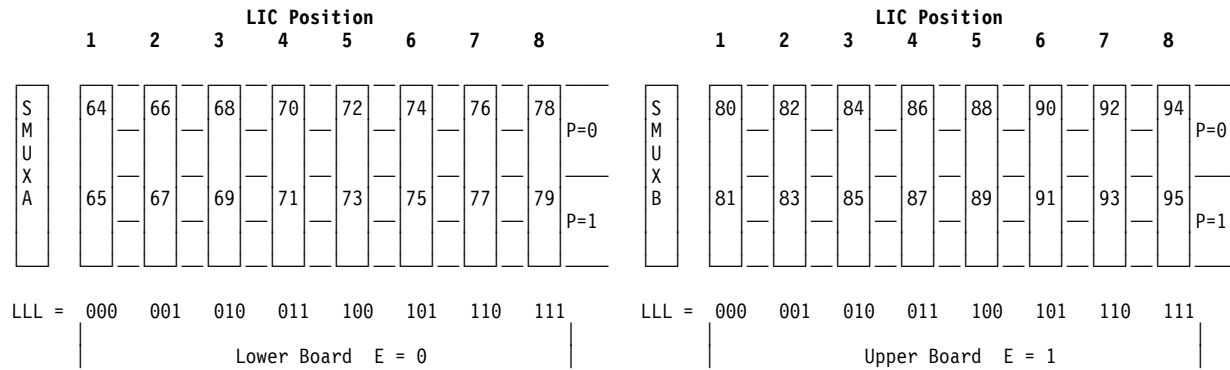

Port Position for LIC Type 6 at 56 kbps

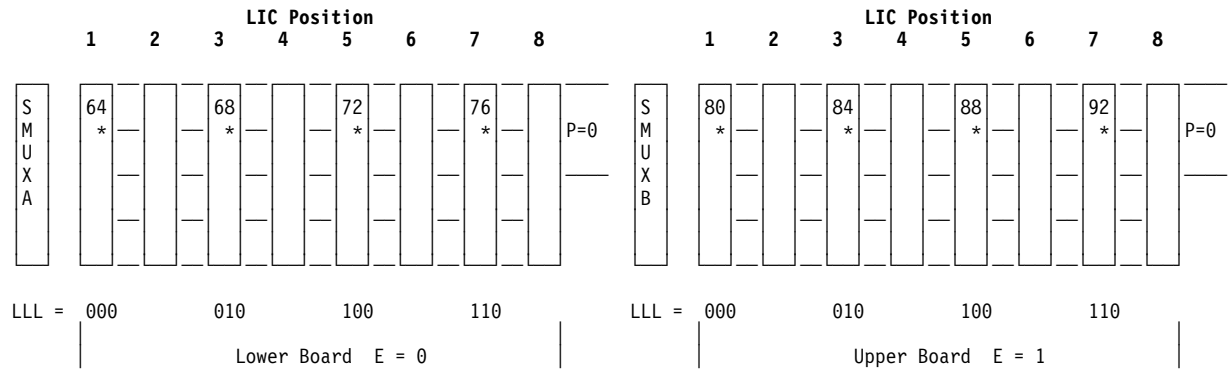

* = The LIC cassette can be plugged in an odd position only.

For plugging restrictions refer to "LIC Type 6, Plugging Limitations" on page 4-11.

Note: LIC type 5 and LIC type 6 are installed starting from line address 064.

TSS Line Addressing for LICs 5-6

During Transmit Operation

Line	Byte 1							Hex
	0	0	E	L	L	P	I	
64	0	0	0	0	0	0	0	00
65	0	0	0	0	0	0	1	02
66	0	0	0	0	0	1	0	04
67	0	0	0	0	0	1	1	06
68	0	0	0	0	1	0	0	08
69	0	0	0	0	1	0	1	0A
70	0	0	0	0	1	1	0	0C
71	0	0	0	0	1	1	1	0E
72	0	0	0	1	0	0	0	10
73	0	0	0	1	0	0	1	12
74	0	0	0	1	0	1	0	14
75	0	0	0	1	0	1	1	16
76	0	0	0	1	1	0	0	18
77	0	0	0	1	1	0	1	1A
78	0	0	0	1	1	1	0	1C
79	0	0	0	1	1	1	1	1E
80	0	0	1	0	0	0	0	20
81	0	0	1	0	0	0	1	22
82	0	0	1	0	0	1	0	24
83	0	0	1	0	0	1	1	26
84	0	0	1	0	1	0	0	28
85	0	0	1	0	1	0	1	2A
86	0	0	1	0	1	1	0	2C
87	0	0	1	0	1	1	1	2E
88	0	0	1	1	0	0	0	30
89	0	0	1	1	0	0	1	32
90	0	0	1	1	0	1	0	34
91	0	0	1	1	0	1	1	36
92	0	0	1	1	1	0	0	38
93	0	0	1	1	1	0	1	3A
94	0	0	1	1	1	0	0	3C
95	0	0	1	1	1	1	0	3E

During Receive Operation

Line	Byte 1							Hex
	0	0	E	L	L	P	I	
64	0	0	0	0	0	0	1	01
65	0	0	0	0	0	0	1	03
66	0	0	0	0	0	1	0	05
67	0	0	0	0	0	1	1	07
68	0	0	0	0	1	0	0	09
69	0	0	0	0	1	0	1	0C
70	0	0	0	0	1	1	0	0D
71	0	0	0	0	1	1	1	0F
72	0	0	0	1	0	0	0	11
73	0	0	0	1	0	0	1	13
74	0	0	0	1	0	1	0	15
75	0	0	0	1	0	1	1	17
76	0	0	0	1	1	0	0	19
77	0	0	0	1	1	0	1	1B
78	0	0	0	1	1	1	0	1D
79	0	0	0	1	1	1	1	1F
80	0	0	1	0	0	0	0	21
81	0	0	1	0	0	0	1	23
82	0	0	1	0	0	1	0	25
83	0	0	1	0	0	1	1	27
84	0	0	1	0	1	0	0	29
85	0	0	1	0	1	0	1	2B
86	0	0	1	0	1	1	0	2B
87	0	0	1	0	1	1	1	2F
88	0	0	1	1	0	0	0	31
89	0	0	1	1	0	0	1	33
90	0	0	1	1	0	1	0	35
91	0	0	1	1	0	1	1	37
92	0	0	1	1	1	0	0	39
93	0	0	1	1	1	0	1	3B
94	0	0	1	1	1	0	0	3D
95	0	0	1	1	1	1	1	3F

HPTSS Line Addressing

Up to two lines can be addressed for each HPTSS, but only one is active at a time.

Byte 1 bit 6 selects the port:

- 0 = port 1
- 1 = port 2

Line numbers 1028 through 1031 are dedicated for HPTSS use.

Adapter Number	Line Address	Tailgate Position
3 Port 1	1028	01Q-C0 J2
Port 2	1029	01Q-C0 J1
4 Port 1	1030	01Q-D0 J2
Port 2	1031	01Q-D0 J1

ESS Line Addressing

Up to two lines can be addressed for each ESS.

Byte 1 bit 6 selects the port:

- 0 = port 1
- 1 = port 2

Line numbers 1060 through 1063 are dedicated for ESS use.

Adapter Number	Line Address	Tailgate Position
3 Port 1	1060	01Q-C0 J2
Port 2	1061	01Q-C0 J1
4 Port 1	1062	01Q-D0 J2
Port 2	1063	01Q-D0 J1

Token-Ring Adapter (TRA) Addressing

Up to two TRMs can be installed on the 3745.

They are addressed at TA time of the IOH.

The TRM address is included in the TA halfword of the IOH.

- Byte 0, bit 0 is the IOC connection.
- Byte 0, bits 1-4 is the type address and is equal to 1 0 0 1.
- Byte 0, bits 5-7 is the group address. This group address is unique and set to 0 0 0.
- Byte 1, bit 4 indicates the origin: 0 = Control program
1 = MOSS
- Byte 1, bit 5 indicates whether a TRM or a TIC is addressed:
 - Bit 5 = 0 indicates a command to a TIC.
 - Bit 5 = 1 indicates a command to a TRM.
- Byte 1, bit 6 is the slot address: 0 = Slot 1
1 = Slot 2

IOC bus at TA time

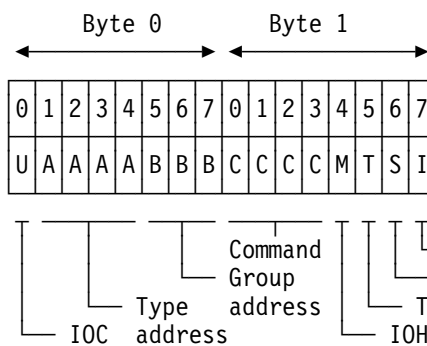

IOC bus at TD time

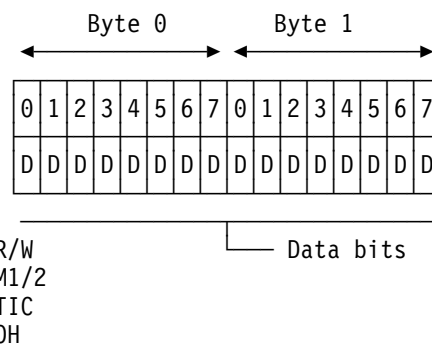

IOC bus at TA time

TRM	Byte 0								Byte 1							
	0	1	2	3	4	5	6	7	0	1	2	3	4	5	6	7
	U	A	A	A	A	B	B	B	C	C	C	C	M	T	S	I
1	0	1	0	0	1	0	0	0			0	0		1	0	
2	0	1	0	0	1	0	0	0			0	0		1	1	

Token-Ring Line Addressing

Two token-ring adapters (TRA) can be installed.
See Figure 3-2 on page 3-5.

The TRA is addressed at TA time of the IOH

One TRM controls 2 TICs. Byte 1, bits 2 and 3 from the command are used to identify one of the TICs.

- If bits 2 and 3 = 0 0, TIC 1 is addressed.
- If bits 2 and 3 = 0 1, TIC 2 is addressed.

The TIC is addressed when byte 1, bit 5 = 0.

Token-Ring Address

IOC bus at TA time

← Byte 0 Byte 1 →

TRM	TIC	0	1	2	3	4	5	6	7	0	1	2	3	4	5	6	7
		U	A	A	A	A	B	B	C	C	C	C	M	T	S	I	
1	1	0	1	0	0	1	0	0	0			0	0		0	0	
	2	0	1	0	0	1	0	0	0			0	1		0	0	
2	3	0	1	0	0	1	0	0	0			0	0		0	1	
	4	0	1	0	0	1	0	0	0			0	1		0	1	

Line numbers 1088 and 1091 are dedicated for TRSS use.

Adapter Number	TIC	Line Address	Tailgate Position
1	1	1088	01Q-A0 J2
	2	1089	01Q-A0 J1
2	1	1090	01Q-B0 J2
	2	1091	01Q-B0 J1

Note: More token-ring connections can be provided through the 3746-900. Refer to the *3746 Model 900, Hardware Maintenance Reference* (online documentation) for details.

Adapter Bypass Mechanism

This procedure is not valid for 3745 Model 17A if a 3746 Model 900 is installed.

For Line Adapters

There is no bypass mechanism. Any missing LA must be replaced by a BPC card except if it is the last in the chain.

For Channel Adapters

- The bypass mechanism is under MOSS and NCP control through the CDF (at IPL time or by a 'shut-down' command).
- The MOSS tells the CAs what the adapter configuration is on the bus (each CA must know if the preceding and the next adapter are present or not).
- Two chains are involved in this mechanism:
 - Cycle Steal Grant (CSG).
 - Autoselection chain.

Cycle Steal Grant (CSG) and Autoselection Mechanism for Model 170

Without TPS and Without HPTSS/ESS

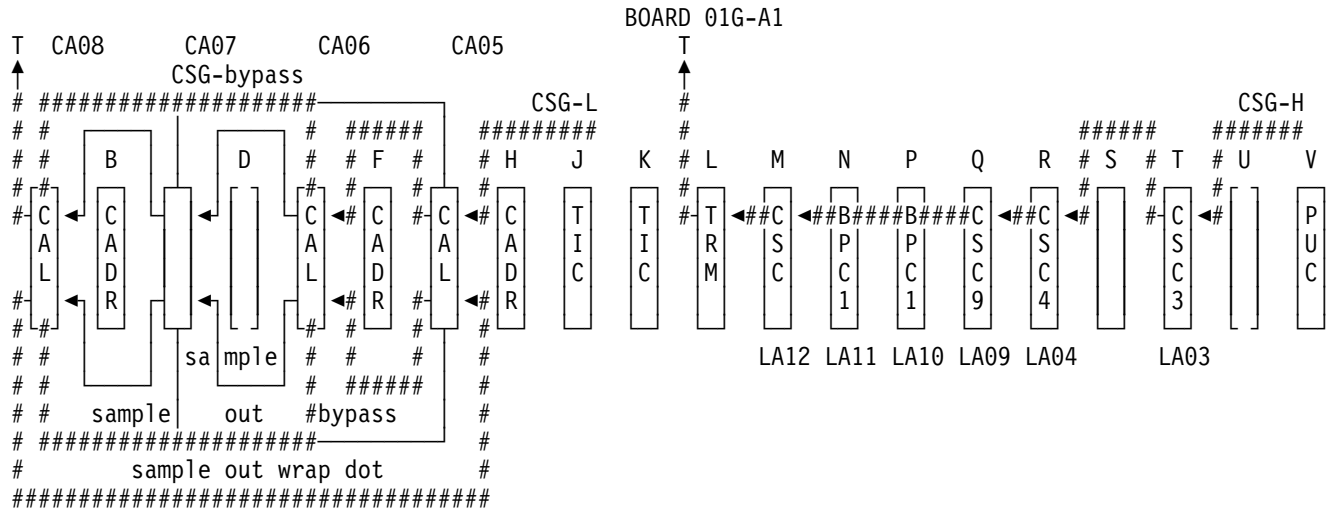

With TPS and HPTSS/ESS

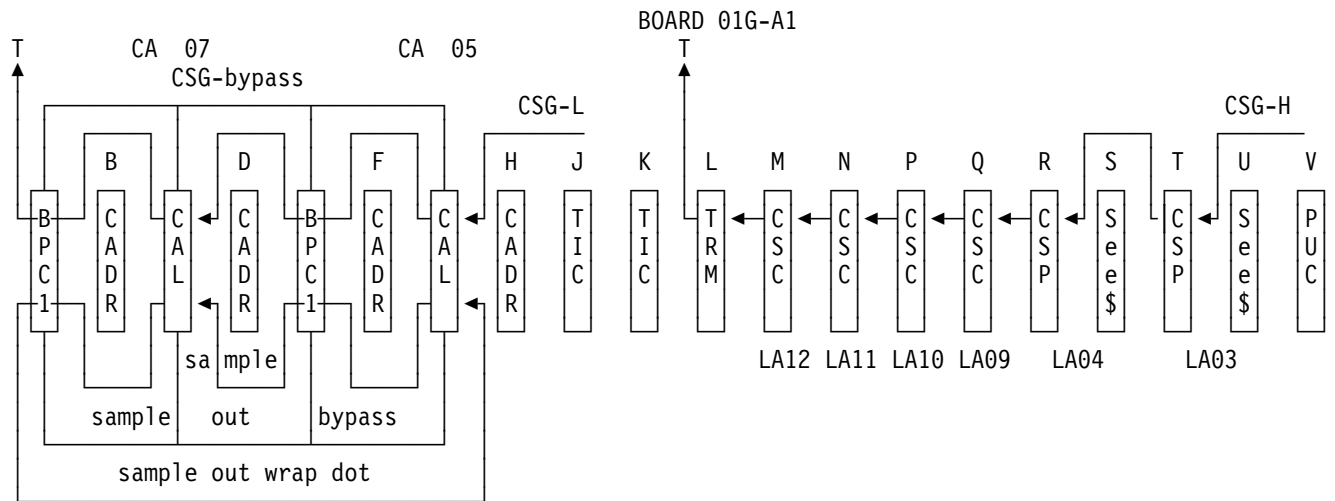

\$ = Can be FESH or EAC card.

CSG and sample paths defined by the bypass mechanism for this example of configuration

Cycle Steal Grant (CSG-L) Scenario for CAs

As an answer to 'CSR' from any CA, the CCU raises 'CSG-L' line to the CAs.

This line is propagated as follows:

- INPUT:
 - The first CA in the chain is looking at 'CSG-L' from the CCU.
 - Other CAs are looking at:
 - 'CSG-through' line if the previous CA is in the chain.
 - 'CSG-bypass' line if the previous CA is not in the chain.
- OUTPUT:
 - The CA which has raised 'CSR' keeps the 'CSG' and breaks the chain.
 - Other CAs raise:
 - 'CSG-through' if the next CA is in the chain.
 - 'CSG-bypass' if the next CA is not in the chain.

One CA only can be looking at 'CSG-bypass' and one CA only can raise 'CSG-bypass', the consequence is that only one CA or group of consecutive CAs can be missing on the bus.

If a CA is TPS (CA01 in the drawing), the next CA must be replaced by a BPC card to propagate the 'CSG-through' line.

Autoselection Scenario for CAs

As an answer to 'level 3' interrupts from any CA, the CCU issues an IOH X'0F' to the bus.

There is always one CA initially selected in the chain.

This IOH start the propagation of the 'sample' line from the initially selected CA as follows:

- INPUT:
 - The first CA on the bus is looking at 'sample out wrap dot' from the last CA.
 - Other CAs are looking at:
 - 'Sample' line if the previous CA is in the chain.
 - 'Sample-bypass' line if the previous CA is not in the chain.
- OUTPUT:
 - The CA which is to be selected keeps the 'sample' and breaks the chain.
 - The last CA on the bus raises 'sample out wrap dot'.
 - Other CAs raise:
 - 'Sample' if the next CA is in the chain.
 - 'Sample out-bypass' if the next CA is not in the chain.

One CA only can be looking at 'sample-bypass' line and one CA only can raise 'sample-bypass', the consequence is that only one CA or group of consecutive CAs can be missing on the bus.

If a CA is TPS, the next CA must be replaced by a BPC card to propagate the 'sample' line.

BPC Card Installation Rules (Model 170)

- Channels adapters:
One BPC1 card is required in positions A2 and E2 for TPS.
- Line adapters:
 - If no TRA is installed:
 - If no CSC is installed in position Q2:
No BPC1 or BPC2 are required.
 - If a CSC is installed in position Q2:
One BPC1 is required in positions R2 and T2 if no CSC or CSP are installed in these positions.
 - If a TRA is installed:
One BPC1 is required in the free positions of the CSC and CSP cards.

Cycle Steal Grant (CSG) and Autoselection Mechanism for Model 130 With TPS

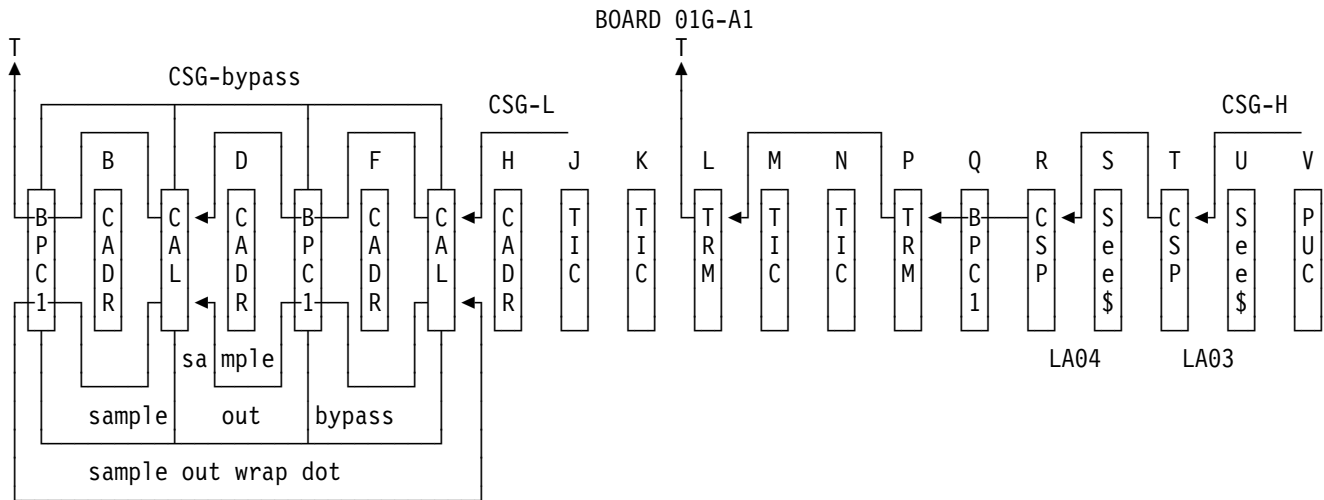

\$ = Can be FESH or EAC card.

BPC1 card installation rules

- Channels adapters:
One BPC1 card is required in positions A2 and E2 for TPS.
- Line Adapters:
 - If no TRA is installed: No BPC1 or BPC2 are required.
 - If a TRA is installed:
One BPC1 is required in position Q2. One BPC1 is required in positions R2 and T2 if no CSP is installed. One BPC2 is required in position P2.
 - If two TRAs are installed:
One BPC1 is required in position Q2. One BPC1 is required in position R2 and T2 if no CSP is installed.

Cycle Steal Grant (CSG) for Model 150

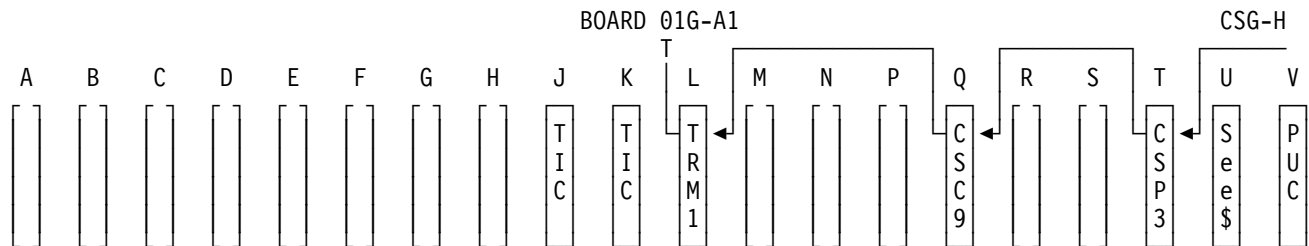

\$ = Can be FESH or EAC card.

BPC1 card installation rules

- One BPC1 is required in position T2 if no CSP is installed.

IOC Bus Scoping Routine

The purpose of the PIO scoping routine is to allow scoping of the PIO tags and data bus.

The following adapters can be exercised using MIOH commands sent from the MOSS:

- CAs
- LAs

If you are working on a 3745 Model 17A connected to a 3746 Model 900, unplug the IOC and DMA buses coming from the 3746-900 and plug ITER and DTER terminators (Location 01G-A1 YJ for DMA buses and 01G-A1 ZA for IOC buses).

ITER and DTER terminator cards (PN 66X0521) are available with the shipping group material.

How to Start the Routine

1. Start the routine by calling routine WA01.
DIAG==> WA01
2. Put in the ADP field the IOC bus number (1) on which scoping is planned.
IOC adapter bus = 1

ADP ≠ ==> 1

3. Put the adapter number in the LINE field

LINE==> 3 (for adapter 03)

4. The screen should look like this:

DIAG==> WA01 ADP ==> 1 LINE==> 3 OPT==> N

5. Then press SEND.

A check is made to see if the selected IOC bus can be used, (checking of bits: enable, present, available, concurrent).

If the conditions are not satisfied for the selection, a message:

'ADAPTER NOT IN CDF', or
'ADAPTER NOT INSTALLED', or
'INVALID REQUEST' is displayed.

If the inputs are correct, a message is then returned to the operator:

'xx¹ 03² SELECTED - ENTER : Roocccddd'

¹ = xx may be TSS, HPTSS, ESS, TRSS, or CA

² = 03 is the adapter number (3-4 and 9-12)

The first part of the message allows the operator to check that the right adapter is selected . The second part of the message prompts the operator to send the three parameters which define the MIOH operation.

Adapter Selection

ENTER: 'Roocdddd' THEN PRESS SEND.

R : is mandatory
oo : defines the OPTION (hexadecimal)
cc : defines the COMMAND (hexadecimal)
dddd : defines the DATA to/from adapter (hexadecimal)

These parameters are checked:

If the inputs are valid the MIOH operation is started according to the specified parameters.

If the inputs are not valid, a message is then returned to the operator :
'INVALID INPUTS - ENTER : Roocdddd'

Parameter Description

Option 'oo': Four options are possible:

1. 'oo'='01' The requested MIOH is executed **only once**. The '01' option may be repeated as long as needed. A message is sent to the operator after each MIOH :
'ENTER : R for another cycle or REE to leave'

Therefore if the answer is 'R', the operator is prompted for another MIOH with the selected adapter:
'ENTER: 'Roocdddd' THEN PRESS SEND'

This allows to perform a write followed by a read operation, because inputs may be different.
2. 'oo'='02' The requested MIOH is executed and **loops** on this MIOH until an error is found. The error is reported only once via a RAC . To continue 'G' (for go) has to be typed, the routine then loops indefinitely until the Power On Reset key is pressed or another error is found.
3. 'oo'='03' This option is identical to option '02', except that **no checking** is made. This allows looping about four times faster, and therefore easier scoping. The routine loops indefinitely until the Power On Reset key is pressed.
4. 'oo'='04' This option is **reserved for the TSS, HPTSS, and ESS**, and is used to scope Adapter Level 1 and Level 2 interrupt requests to the CCU. Commands 10 to 21 can be used only with option 04. Because this option needs a Power On Reset on the CSP, each operation lasts about 10 seconds.

For option 04 at TD time on the IOC bus, byte 1 bit 5 will be ON for level 1 interrupts and byte 0 bit 1 ON for level 2.

COMMAND (or MIOH operation) 'cc' Since the purpose of the scoping routine is only to activate the bus lines and the tag lines on the IOC bus, it is only necessary to be able to execute one type of write operation and the corresponding read operation to check the data previously written.

For this reason the command codes are limited to:

1. 'cc'='01' Defines a write operation to any adapter type. TA values are automatically generated, according to the adapter type and the write operation defined for this adapter.
2. 'cc'='02' Defines a read operation from any adapter type. TA values are automatically generated, according to the adapter type and the read operation defined for this adapter.

In loop mode, (OPTION 'oo'='02' or '03'), when a read operation is requested, the first operation is a write in order to store the data in one register of the addressed adapter. All subsequent operations are read operations in order to recall the data from the register previously written.

3. 'cc'='10' Special for the TSS, HPTSS, and ESS, requests to the selected adapter used with option 04 only, to reset the level 1 interrupt to the CCU. This level 1 is then tested at CCU level and a message: 'LEVEL 1 INTRPT IS RESET' is displayed.
4. 'cc'='11' Special for the TSS, HPTSS, and ESS, used with option 04 only, requests to the selected adapter to set the level 1 interrupt to the CCU. This level 1 is then tested at CCU level and a message: 'LEVEL 1 INTRPT IS SET' is displayed.
5. 'cc'='20' Special for the TSS, HPTSS, and ESS, used with option 04 only, requests to the selected adapter to reset the level 2 interrupt to the CCU. This level 2 is then tested at CCU level and a message: 'LEVEL 2 INTRPT IS RESET' is displayed.
6. 'cc'='21' Special for the TSS, HPTSS, and ESS, used with option 04 only, requests to the selected adapter to set the level 2 interrupt to the CCU. This level 2 is then tested at CCU level and a message: 'LEVEL 2 INTRPT IS SET' is displayed.

DATA: 'dddd' (mandatory for any command) defines either:

- The data (TD value) sent to the adapter through the IOC bus at TD time during a write operation or,
- The data (TD value) received from the adapter through the IOC bus at TD time during a read operation.

For example, data can be hexadecimal:

'5555', 'AAAA',

RACs Generated

When the scoping routine does not run, the following RACs are generated. These RACs must not be entered with the BRC function.

Run the corresponding adapter diagnostic.

RAC Meaning

- 231 Unexpected interrupt CA operation
- 232 Unexpected interrupt TSS operation
- 233 Unexpected interrupt HPTSS/ESS operation
- 234 Unexpected interrupt TRSS operation
- 235 Level 2 not set by TSS, HPTSS, or ESS
- 236 Level 2 not reset by TSS, HPTSS, or ESS
- 237 Level 1 not set by TSS, HPTSS, or ESS
- 238 Level 1 not reset by TSS, HPTSS, or ESS
- 241 Unexpected data from CA
- 242 Unexpected data from TSS
- 243 Unexpected data from HPTSS or ESS
- 244 Unexpected data from TRSS

ERC Meaning

The error reference codes displayed with the RAC have the following meanings:

- 0001 Error during selection
- 0002 Error during write (01 operation)
- 0003 Error during read (02 operation)
- 0004 Error during first write (02 requested)

Error Bit (ERR)

The error bit patterns displayed with the RAC have the following meanings:

For RACs 231 to 238:

Byte 0

- Bit 0 = CA to CCU level 1
- Bit 1 = CA to CCU level 3
- Bit 2 = CA to MOSS level 1
- Bit 3 = CA to MOSS level 4
- Bit 4 = TSS, HPTSS, or ESS to CCU level 1
- Bit 5 = TSS, HPTSS, or ESS to CCU level 2
- Bit 6 = Not used
- Bit 7 = TSS, HPTSS, or ESS to MOSS level 4

Byte 1

- Bit 0 = MOSS level 1 IOC time out
- Bit 1 = MOSS level 1 IOC invalid CCW
- Bit 2 = MOSS level 1 IOC other error
- Bit 3 = CCU level 1 SAR parity error
- Bit 4 = CCU level 1 IOC time out
- Bit 5 = CCU level 1 IOC invalid CCW
- Bit 6 = CCU level 1 IOC other error
- Bit 7 = CA to MOSS level 1 CAIPL

For RACs 241 to 244:

ERR bits = Data received from the adapter

Examples of Scoping Routine on Bus Terminator

A good quality oscilloscope is required (high luminosity).

For pin locations, see "Bus Terminator (TERMI) Connector Pin Assignments" on page 3-60.

Channel Adapter or Token-Ring Adapter

CA 05 or TRA 1
Options: 02 or 03
Command: 02 (read)
Data: 'AAAA'

Oscilloscope:
Sync: +IO line
Calibration: 0.5 μ s

+IO cycle option 2 = 40 ms
+IO cycle option 3 = 13 ms

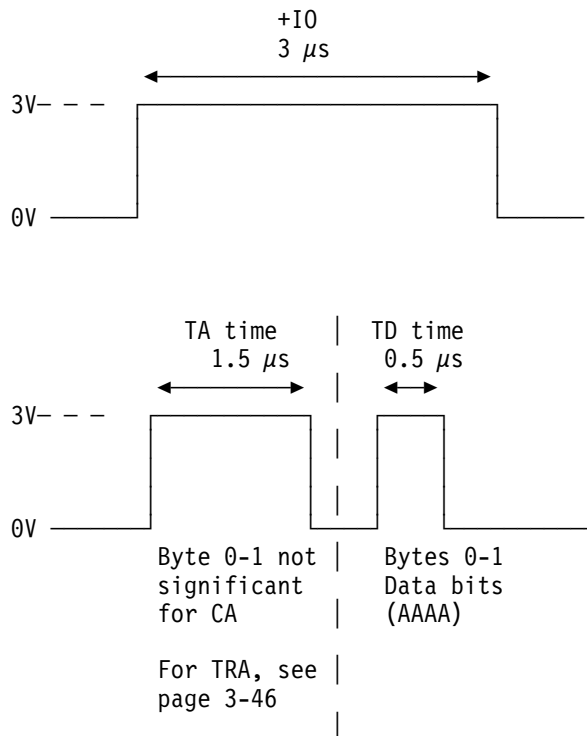

TSS, HPTSS, or ELA

LSS 03 or HSS/ELA 04

Options: 02 or 03

Command: 02 (read)

Data: 'AAAA'

Oscilloscope:

Sync: +IO line

Calibration: 2 μ s

+IO cycle option 2 = 40 ms

+IO cycle option 3 = 13 ms

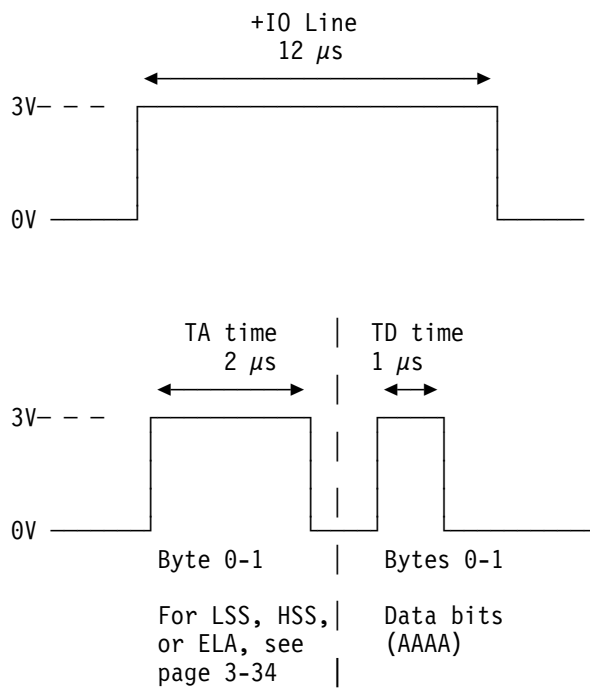

At TA time, for LSS 03 (TSS):

Byte 0 bits P, 3, and 7 are ON

Byte 1 bits 1 and 3 are ON

At TA time, for HSS/ELA 04 (HPTSS/ESS):

Byte 0 bits P, 2, and 7 are ON

Byte 1 bits 1 and 3 are ON

Bus Terminator (TERMI) Connector Pin Assignments

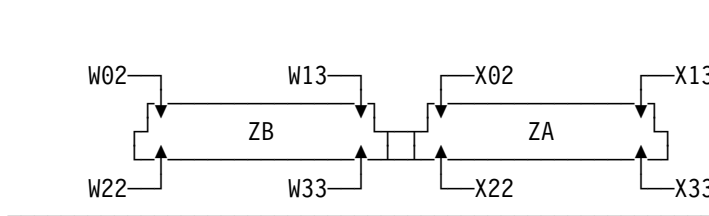

Basic Board Rear Side, TERMI Location

ZB					
+ TA Tag.	W22	W02	+ Data Byte 1 Bit P		
+ TD Tag.	W23	W03	+ Data Byte 1 Bit 0		
+ IO Tag.	W24	W04	+ Data Byte 1 Bit 1		
+ OUT Tag.	W25	W05	+ Data Byte 1 Bit 2		
+ Halt Tag.	W26	W06	+ Data Byte 1 Bit 3		
+ CS Req. Priority.	W27	W07	+ Data Byte 1 Bit 4		
+ Level 2 Priority.	W28	W08	Ground		
+ Valid Byte. . . .	W29	W09	+ Data Byte 1 Bit 5		
+ Modifier.	W30	W10	+ Data Byte 1 Bit 6		
+ End of Chaine . .	W31	W11	+ Data Byte 1 Bit 7		
+ Parity Valid. . .	W32	W12	+ Reset Tag		
+ Valid Halfword. .	W33	W13	+ CA Nohold		
+ IRR	X22	X02	+ CA MOSS POR		
+ CS Req. Low (CA).	X23	X03	+ CA Level 1 to MOSS		
+ CS Req. High (CS)	X24	X04	+ CA Level 4 to MOSS		
+ Data Byte 0 Bit P	X25	X05	+ CA CSG Bypass		
+ Data Byte 0 Bit 0	X26	X06	+ CA CSG Bypass		
+ Data Byte 0 Bit 1	X27	X07	+ CA Valid Feed Auto		
+ Data Byte 0 Bit 2	X28	X08	Ground		
+ Data Byte 0 Bit 3	X29	X09	+ CA Valid Feed Auto		
+ Data Byte 0 Bit 4	X30	X10	+ CA Sample Bypass		
+ Data Byte 0 Bit 5	X31	X11	+ CA Sample Bypass		
+ Data Byte 0 Bit 6	X32	X12	+ CA Sample Wrap DOT		
+ Data Byte 0 Bit 7	X33	X13	+ CS Grant Low		
		ZA			

Chapter 4. Transmission Subsystem (TSS)

The TSS in 3745 Models 130, 150, 160, and 170 Data Flow	4-4
The TSS in 3745 Model 17A Data Flow	4-5
Definitions	4-6
Low-Speed Scanner (LSS)	4-7
Definition	4-7
Communication Scanner Processor (CSP)	4-7
Front-End Scanner Low-Speed (FESL)	4-7
LIC Board	4-7
Definition	4-8
Multiplexer Card (MUX)	4-8
Line Interface Coupler (LIC)	4-9
LIC Types 1 to 4 Characteristics	4-9
LIC Types 5/6 Characteristics	4-11
Line Weights	4-11
LIC Internal Clock Function (ICF)	4-12
Serial Link (SL)	4-13
Communication Scanner Processor (CSP)	4-13
Components	4-13
Local Storage	4-15
Read-Only Storage	4-15
Control Storage	4-15
CSP External Registers	4-15
CCU/CSP Register Use	4-18
Ping/Pong Buffers	4-18
Processor Characteristics	4-18
Error Management	4-18
Scanner States	4-19
Scanner Commands	4-21
Scanner Status After the IML	4-21
Front-End Scanner (FES)	4-23
Throughput	4-23
Data Flow	4-23
Storages	4-24
FESL Reset	4-25
FESL Reset Flow	4-25
Power ON Reset	4-25
Programmed Reset	4-26
Front-End Scanner Adapter (FESA)	4-27
FESA Data Flow	4-27
FESA-CSP Interconnection	4-28
FESA-Serial Link Interconnection	4-28
FESA Description	4-28
FESA RAM Organization	4-28
FESA Inbound/Outbound RAMs Addressing	4-29
FESA-FES Interconnection Management	4-31
Serial Link (SL)	4-34
Connection to LIC Type 5 and LIC Type 6	4-34
Double Multiplexer Card (DMUX)	4-35
DMUX Functions	4-35
MUX 1 or 2 Data Flow	4-36

DMUX Functional Description	4-37
DMUX Reset	4-37
DMUX Hot Plugging	4-38
Single Multiplexer Card (SMUXA/B)	4-39
SMUX Functions	4-39
Transmit Level	4-39
SMUX Data Flow	4-40
SMUX Functional Description	4-42
SMUX Reset	4-42
SMUX Hot Plugging	4-42
LIC Types 1 to 4 Cards	4-43
Interface Lines	4-43
Transmit/Receive Data Mechanism	4-44
LIC Reset	4-44
Line Enable/Disable	4-44
Selective Scanning	4-45
LIC Logical Addressing Function	4-46
LIC Swap	4-46
LIC Address Register Contents	4-47
LIC Control Register	4-47
Enable Clock Mode	4-47
Transmit Clock Gating by RFS (LICs 1, 2, and 3)	4-48
LIC 4 Personalization	4-48
LIC Wideband with Line Speed Higher than 128 kbps	4-48
RTS Through DCE or Data Paths	4-48
LIC Modem-In Process for Non-X.21 Lines	4-48
LIC Modem-In Process for X.21 Lines	4-48
Internal Clock Function (ICF)	4-50
LIC Wraps	4-51
Hot Plugging of LICs	4-53
LIC Types 5 and 6 DTE Function	4-54
Transmit/Receive Data Mechanism	4-54
LIC Reset	4-54
Line Enable/Disable	4-55
Selective Scanning	4-55
LIC Swap	4-55
LIC Address Register Contents	4-55
LIC Control Register	4-55
LIC Wraps	4-55
LICs Hot Plugging	4-56
LIC Type 5 DCE Function	4-57
Maintenance Approach	4-57
Data Flow	4-57
Speeds	4-57
Configurations	4-58
Data Encoding and Modulation	4-61
DCE to Telephone Line Interface	4-63
Transit Time	4-64
RFS Delay	4-64
LIC Type 5 Panel	4-65
Line Specifications	4-65
Options and Configurations	4-67
Host Support	4-70
Manual Tests	4-72

Alarm Tone Detection	4-72
DCE Configuration	4-73
Portable Keypad Display (PKD)	4-74
PT2/3	4-79
LIC Type 6 DSU/CSU Function	4-80
Connection to US DDS	4-80
Limited Distance Connection	4-80
Maintenance Approach	4-80
Data Flow	4-80
Speeds	4-81
Configurations	4-81
Data Format	4-82
Modulation Technique	4-82
DSU/CSU to Line Interface	4-82
Transit Time	4-83
RFS Delay	4-83
LIC Type 6 Panel	4-84
Line Specifications	4-84
Options and Configurations	4-85
Host Support	4-86
DDS Loop	4-87
Alarm Tone Detection	4-87
DSU/CSU Configuration	4-88
Portable Keypad Display (PKD)	4-88
Manual Tests	4-91
PT2/3	4-91
Problem Determination Aid for LIC Types 1 to 4	4-92
Intermittent Error Messages or Messages Lost	4-92
Wrap Tests Controlled from the Host	4-93
Wrap Tests Controlled from the MOSS	4-94
Problem Determination Aid for LIC Type 5 and LIC Type 6	4-95
Wrap Tests Controlled from the Host	4-95
Wrap Tests Controlled from the MOSS	4-95
Manual Tests Controlled from the PKD	4-95
LIC Line Analysis Procedures (LLAP)	4-99
TSS Interface Cables	4-100

The TSS in 3745 Models 130, 150, 160, and 170 Data Flow

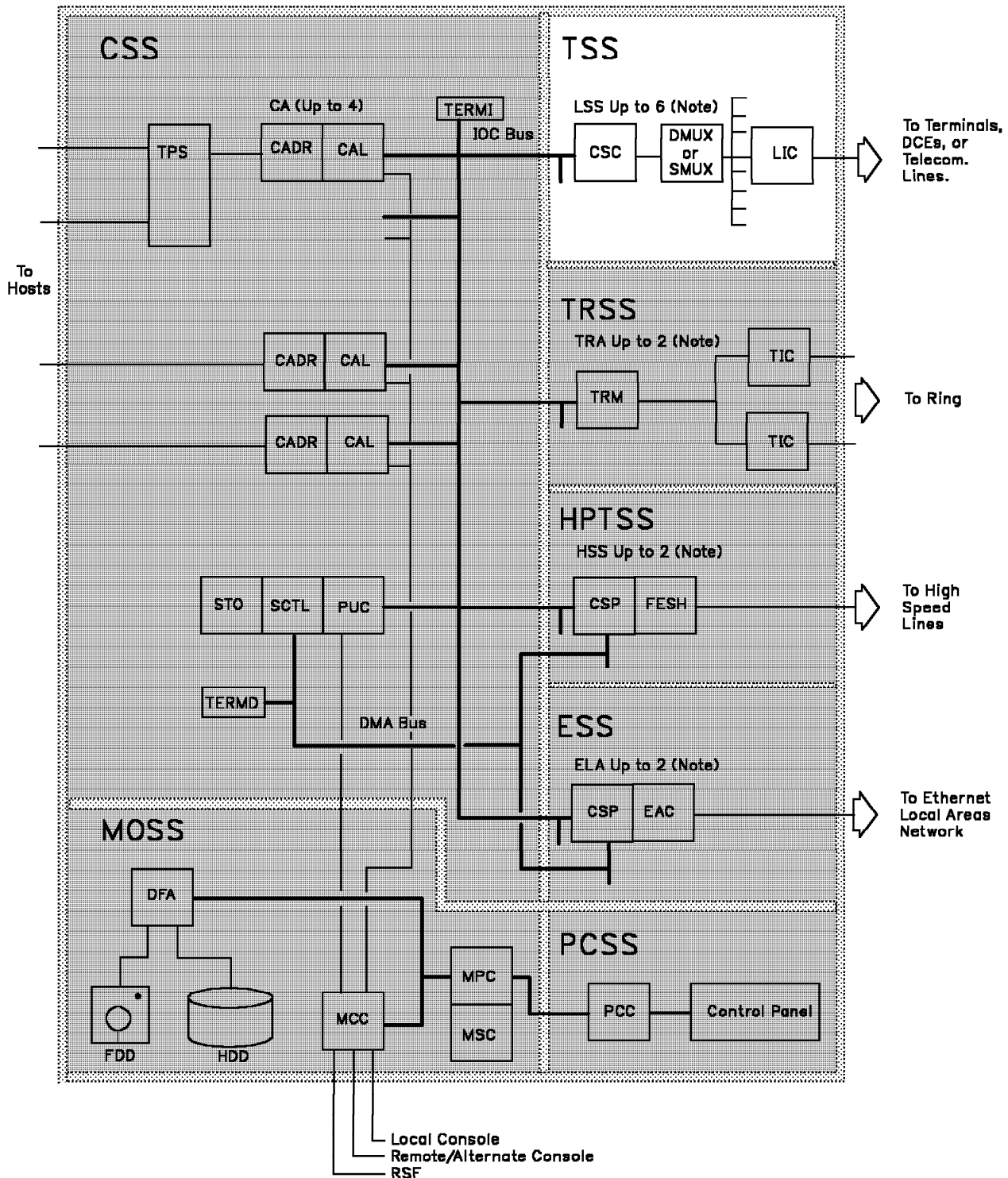

(Note) The number of LSS+HSS+ELA does not exceed 6

The TSS in 3745 Model 17A Data Flow

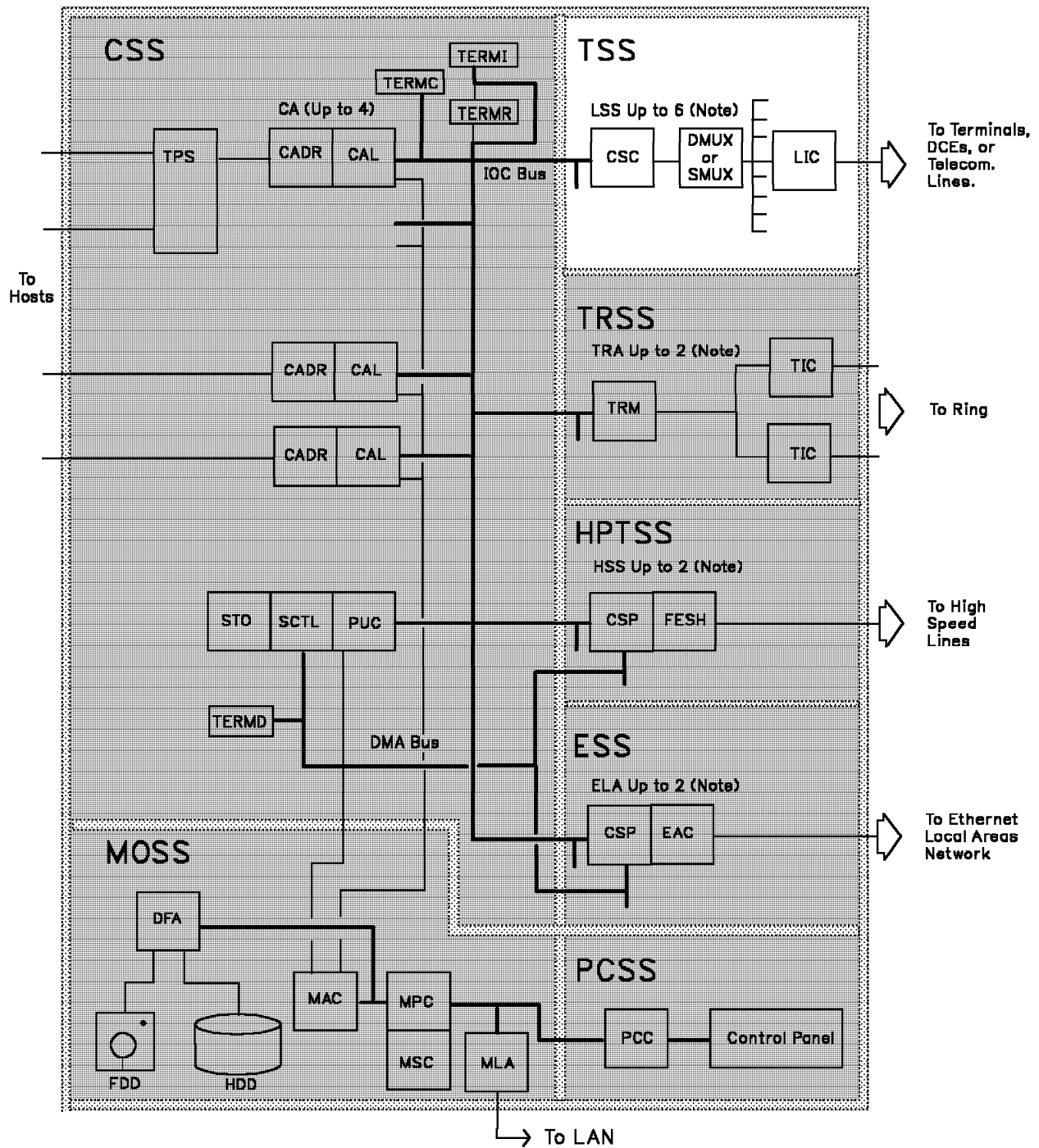

(Note) The number of LSS+HSS+ELA does not exceed 6

Figure 4-1. The TSS in 3745 Model 17A Data Flow. For model 17A, DMA and IOC buses are connected to the CBC in the 3746-900. This MLA card links the MOSS to the Service Processor through a LAN.

Definitions

The TSS consists of low-speed scanners (LSSs) associated to LIC a board through serial links.

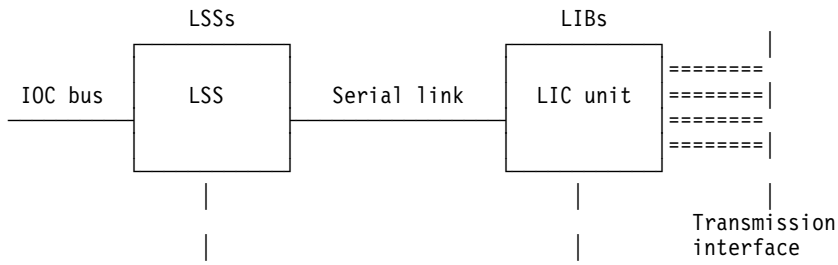

However, it is possible to connect any LIC board to any low-speed scanner (LSS) by simply moving the serial link cables.

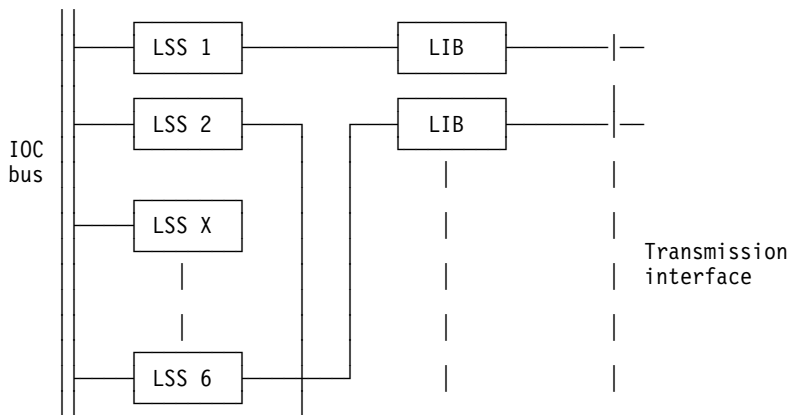

Low-Speed Scanner (LSS)

Definition

A low-speed scanner (LSS) is located on a communication scanner card (CSC) consisting of:

- A communication scanner processor (CSP)
- A front-end scanner low-speed (FESL).

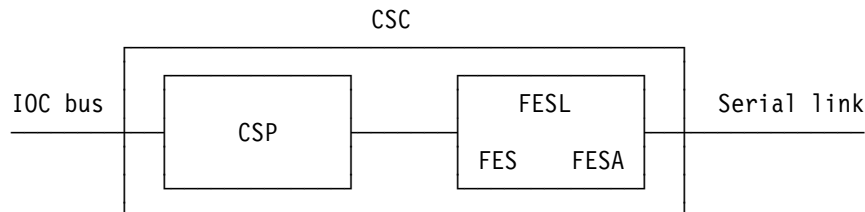

Communication Scanner Processor (CSP)

The communication scanner processor (CSP):

- Supports various line protocols with partial handling of the data link control for BSC and SDLC lines. (The microcode allows the implementation of specific customer protocols.)
- Provides character buffering and cycle steal transfer into CCU main storage
- Supports start-stop with: 8/5, 9/7, 10/7, 10/8, 11/8 bits, BSC (EBCDIC, ASCII), SDLC, DIAL, X.21 native and X.21 bis
- Controls transmission interfaces
- Handles a variable number of lines depending on the protocol and transmission speed
- Provides four types of operating mode with NCP/EP
- Performs the checkout of the ROS code
- Interconnects the IOC buses through the receivers and drivers.

Front-End Scanner Low-Speed (FESL)

The front-end scanner low-speed (FESL) provides logical connection between the CSP and the LIC unit. It is composed of:

- The front-end scanner (FES)
- The front-end scanner adapter (FESA).

FES: It is composed of two layers:

- The front-end layer serializes and deserializes the characters, provides line service management depending on the protocols and exchanges the characters with the scanner processor.
- The scanner base layer communicates with the CSP via several paths:
 - An asynchronous path is used by the CSP microcode to initialize and send commands to the FESL and the LICs.
 - A cycle steal path supports data exchange of one halfword with the CSP control store.

An interrupt mechanism is used to request line service management.

FESA: The FESA converts FES parallel data into a serialized bit stream and conversely to communicate with the LIC units. In addition, the FESA performs modem-in control lead confirmation.

LIC Board

Definition

A line interface coupler (LIC) board consists of:

- Multiplexer cards (MUXs) and
- Line interface coupler cards (LICs).

Depending on the type of LIC implemented, the above elements are named:

LIB1 for LICs 1 to 4 on models 150-170

LIB2 for LICs 5 and 6 on models 150-170

LIB3 for LICs 1 to 4 on model 150.

Model 130: NO 150: LIB1 170: LIB1	Model 130: NO 150: LIB2 170: LIB2
Model 130: NO 150: LIB3 170: LIB1	Model 130: NO 150: NO 170: LIB1 or LIB2

Boards viewed from the rear part of the machine

Multiplexer Card (MUX)

Double Multiplexer Card (DMUX) DMUX is associated with LIC1s to LIC4s on LIB1.: It provides two serial link attachments to connect to two scanner units. Each of them:

- Converts the serial link bit stream in a suitable form for LIC buses
- Performs the serial link clock recovery, synchronization, and repowering
- Manages LIC control and clocking.

The first MUX can attach up to:

- 8 LICs to one scanner if the second one is not used.
- 4 LICs to one scanner and the second MUX either (see TSS definition).

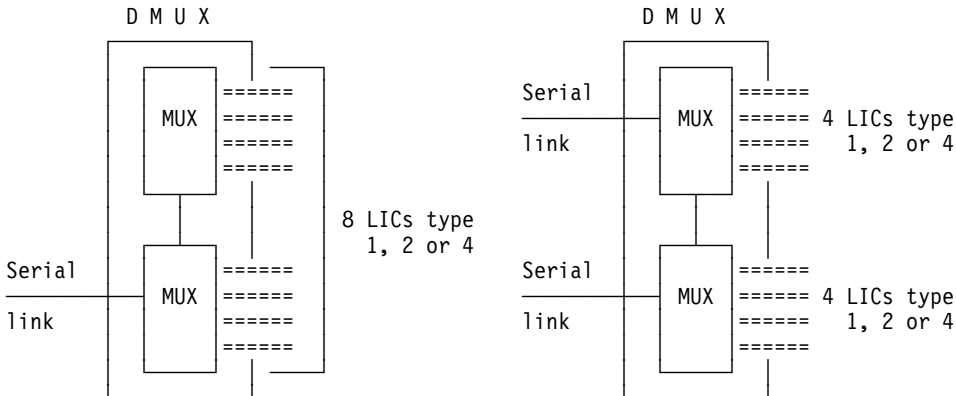

Single Multiplexer Card (SMUX) SMUXA and SMUXB are slightly different in packaging but are functionally identical.

- SMUXA is associated with eight LIC type 5 and LIC type 6 on lower LIB2.
- SMUXB is associated with eight LIC type 5 and LIC type 6 on upper LIB2.

Depending on the transmission rate in a given LIB2, only one scanner may be needed for that LIB2. In that case, the SMUXB only bypasses the signals and controls from the SMUXA to the upper LIB2.

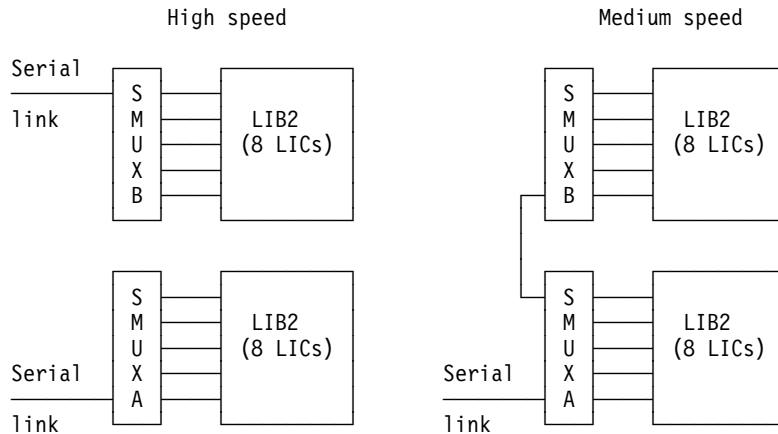

The SMUX cards provide one or two serial link attachment(s) to one or two scanner unit(s). Each of them:

- Converts the serial link bit stream in a suitable form for LIC buses
- Performs the serial link clock recovery, synchronisation and repowering
- Manages LIC control and clocking
- Provides 1 MHz clock signal to the LIC type 5 and LIC type 6
- Provides a 4-bit transmit level bus to the LIC type 5 DCEs.

Line Interface Coupler (LIC)

One line interface coupler (LIC) attaches up to four FDX/HDX lines to the controller. Two main families of LICs are available:

1. Types 1 to 4 (DTE functionally) to attach up to four:
 - Stand-alone DCEs and/or
 - Direct-attached DTEs.
2. Types 5 and 6 (DTE plus DCE functions) to attach up to two telecommunication lines.

LIC Types 1 to 4 Characteristics

	LIC Type 1	LIC Type 2 (RPQ) (note 5)	LIC Type 3	LIC Type 4A (note 4)	LIC Type 4B high-speed (note 4)
Line interface	V.24 (RS-232C), V.25 autocal (RS-366), X.21 bis, X.20 bis, V.25 bis	US wideband. Services 8751, 8801 and 8803 Bell 303	V.35 high-speed	X.21 medium-speed	X.21 high-speed

	LIC Type 1	LIC Type 2 (RPQ) (note 5)	LIC Type 3	LIC Type 4A (note 4)	LIC Type 4B high-speed (note 4)
Transmission speed	Up to 19 200 bps (Note 1)	Up to 230 400 bps (Note 1)	Up to 256 000 bps (Note 1)	Up to 9600 bps (Note 1)	Up to 256 000 bps (Note 1)
Number of lines	Up to four	One	One	Up to four	One
Transfer mode	Half-duplex or duplex	Half-duplex or duplex	Half-duplex or duplex	Half-duplex or duplex	Half-duplex or duplex
Protocols	Start-stop, BSC, SDLC	BSC and SDLC	BSC and SDLC	SDLC	SDLC
DTE clocking (Note 2)	Up to 19 200 bps	Not allowed	Not allowed	Not allowed	Not allowed
Direct attachment (Note 3)	Up to 19 200 bps	Not allowed	Up to 245 760 bps	Up to 9600 bps	From 19 200 to 245 760 bps

Notes:

1. The total number of LICs per CSC is not limited by performance considerations (refer to "Selective Scanning" on page 4-45 for description).
2. Called 'internal clock' on CDF information screen.
3. Direct attachment allowed with internal clock function (ICF).
4. LIC type 4A and LIC type 4B are physically identical (same part number). The microcode sets the LIC to the appropriate type at set mode time.
5. LIC type 2 is available only on RPQ basis.

LIC Types 5/6 Characteristics

	LIC Type 5	LIC Type 6
Line interface	Normal quality or M.1020/1025 4-wire tele-communication lines	DDS, local loop, or unloaded baseband 4-wire lines
Transmission speed	<ul style="list-style-type: none"> • 4800 bps • 9600 bps • 14 400 bps 	<ul style="list-style-type: none"> • 9600 bps • 19 200 bps • 56 000 bps
Number of lines	Two	One
Transfer mode	Half-duplex or duplex	Half-duplex or duplex
Protocols	BSC and SDLC	BSC and SDLC
DTE clocking	Not allowed	Not allowed
Direct attachment	Not allowed	Not allowed

LIC Type 6, Plugging Limitations

Speeds \leq 19 200 bps

The LIC type 6 can be plugged contiguously in all card positions of the board.

Speed = 56 000 bps

Only the odd position out of a pair (even/odd) of card positions can be used to plug the LIC type 6. In this case:

- The LIC type 6 must be plugged in the odd position.,
- Any attempt to plug a LIC in the empty position associated with the LIC type 6 makes the latter inoperative with its yellow LED flashing to signal that condition.
- Any CDF change involving a 56 000 bps LIC 6 plugged in even position will be ignored.

Line Weights

The weight of a line is a value (0.4 through 100) that represents the percentage of scanner occupation. The total weight of all the lines connected to a scanner must be less than or equal to 100.

The maximum number of LIC positions supported per low-speed scanner depends on the line with the highest transmission speed connected to the scanner, and is limited to:

- Eight LIC1s to LIC4s per scanner (LIB1), or
- Four LIC1s to LIC4s per scanner (LIB3, on model 150 only), or
- Sixteen LIC type 5 or LIC type 6 per scanner (LIB2)

For each speed, LIC types 1/4A/5 have two weights per protocol depending on the number of LICs per scanner.

The line weight can be calculated by using the formula:

$$\text{Weight} = \frac{\text{Speed (bps)}}{K}$$

where K is specified by the chart below:

Line Protocol	LIC Types 1/4A/5		LIC Types 3/4B/6
	Number of LIC 1/4A or Number of LIC 5 Pairs per LSS		
	≤ 4	> 4	
SDLC FDX	1920	1536	2560
<ul style="list-style-type: none"> • SDLC HDX • BSC EBCDIC NCP • BSC EP 	3456	3072	4052
BSC ASCII NCP	2420	2016	3041
Start/stop (burst mode)	43 x B, where B is the number of bits/character (for example 430 if 10-bit characters)		

Refer to the *Connection and Integration Guide*, SA33-0129 Appendix B, for more information to calculate the line weights.

Complete information to populate the 3745 properly can be displayed or printed from the *3745 Configuration Program* diskette, GA33-0093 running in any IBM PC.

Inactive Lines

Unlike earlier communication controllers, 3745 LICs are not scanned if **all** the lines connected to them are inactive, and hence do not load the scanner.

LIC Internal Clock Function (ICF)

Implemented on each LIC 1 to 4, the internal clock function (ICF) provides the clock control to:

- Non-clocked DCEs
- Direct-attached terminals.

Serial Link (SL)

A serial link interconnects a LIC board and a scanner unit via MUX and CSC cards.

Communication Scanner Processor (CSP)

The communication scanner processor (CSP) operates under the control of the scanner microcode loaded from the hard disk drive or diskette drive into CSP storage during IML.

The CSP is located on the communication scanner card (CSC).

Components

As shown on the next data flow the CSP:

- (A) Connects to the IOC bus to receive or transmit data and controls
- (B) Executes the instructions of the microcode to transmit and receive data, supports the link protocols, translates characters, and controls the communication interface.
- (C) Stores the microcode, the transmitted/received data, the line interface parameters, and the diagnostics
- (D) Provides registers in local storage for current CSP operation and permanent code in the ROS to start the microcode IPL.
- (E) Controls the storage and manages (by hardware only) the cycle steal with the FESL.
- (F) Controls the CSP interrupts.
- (G) Provides control storage address compare, and generates a CSP interrupt when the selected address is encountered.
- (H) Detects and reports the CSP errors via the CSP error register.
- (I) Generates clocking signals to the processor, to the FESL and their associated logic from the basic 49.152 MHz clock.

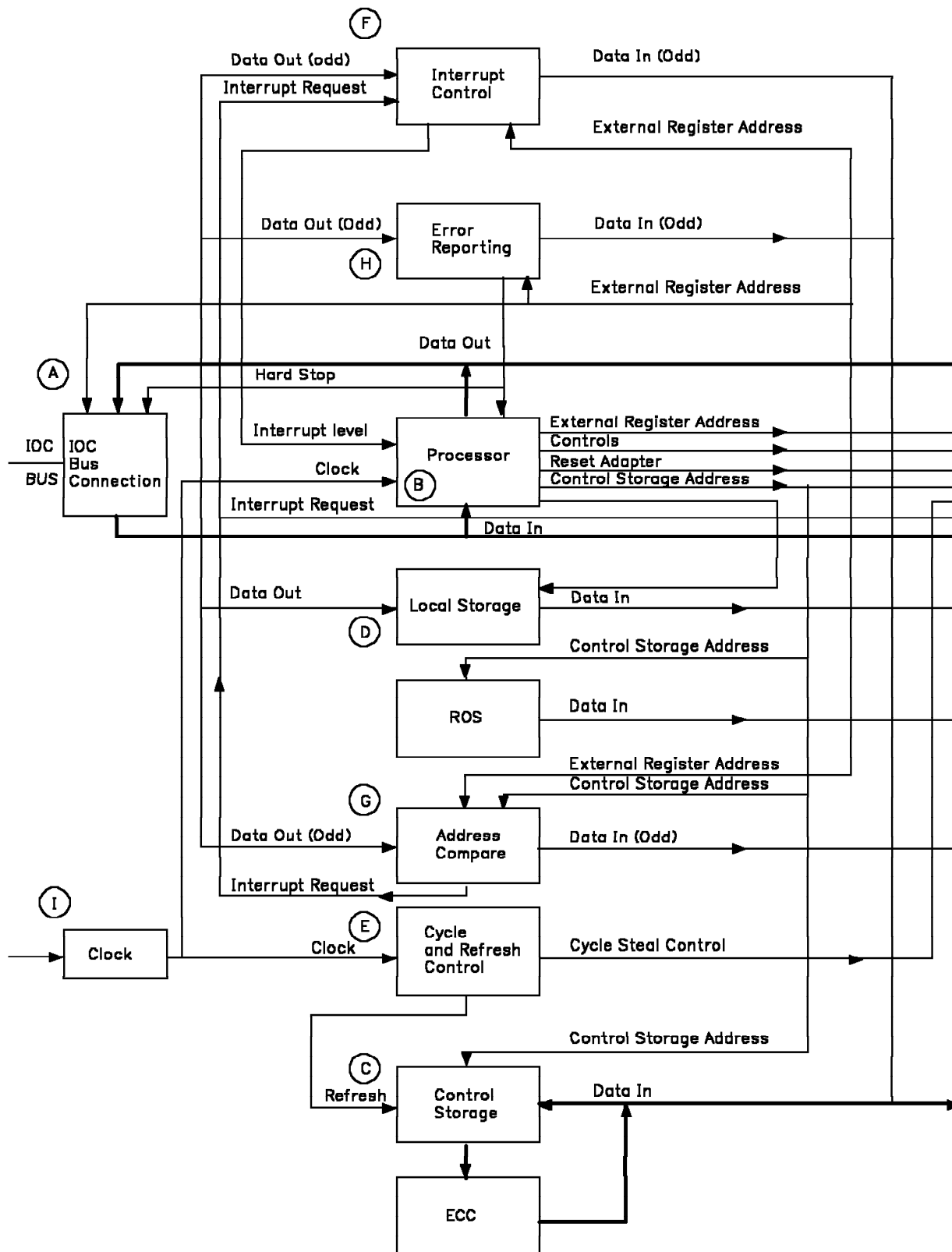

Local Storage

The local storage is 128 bytes long (64 halfwords) addressed by byte or by halfword. It is organized in 16 blocks (or pages) of eight local storage registers (LSRs), each of them being one-byte long, used to store the microcode pointers, the cycle steal and command queue control blocks, the program status words, and working register.

The local storage registers can be displayed or altered from the operator console, using the TSS functions.

Read-Only Storage

The read-only storage (ROS) is 8K bytes long (4K halfwords) addressed by halfwords. It includes all the permanent code needed to IML or dump the microcode and to perform diagnostics.

The ROS can be displayed from the operator console, using the TSS functions.

Control Storage

The control storage is 64K halfwords long addressed by halfword.

In each module, an error checking and correction (ECC) mechanism detects and corrects the single or double bit errors (soft or hard) of that module.

When an unrecoverable double error is detected, register X'03' bit 1 is set ON, a hardstop condition is raised, and two data bytes with parity are sent to the CCU.

The control storage is used to store:

- The scanner microcode.
- The buffers for the transmitted and received data, and the line control blocks and parameters.
- Tables and service buffers.

The control storage can be displayed or altered from the operator console, using the TSS functions.

CSP External Registers

The CSP uses 32 eight-bit external registers located in the main communication scanner components: IOC bus connection, address compare, error reporting, and front-end scanner.

The external registers are connected to the CSP via the data in (odd) bus during read operations, and data out (odd) bus during write operations. Their bits are set ON or OFF by the hardware or the microcode.

The external registers can be displayed or altered from the operator console, using the TSS functions.

Address	Function
00	Miscellaneous control
01	IOC bus control
02	IOC bus service
03	CSP error
04	CSP miscellaneous
05	External interrupt request
06	Not used
07	Synchro/configuration data set
08	Not used
09	Not used
0A	Fast get line ID byte 0
0B	Fast get line ID byte 1
0C	Scanner alternate address
10	Extended interrupt request
11	Not used
12	Interrupt request line interface address
13	Asynchronous access RAM A/B/C
14	Data in/out
15	Asynchronous access RAM A/B/C
16	Asynchronous operation status
17	FESL general command
18	Not used
19	PCI/IO interrupt level request
1A	Current CSP interrupt
1B	Address compare control
1C	Address compare byte 0
1D	Address compare byte 1
1E	CSP interrupt masks
1F	Local storage page register (hex)

FESL
(Scheduler and Address Selector)

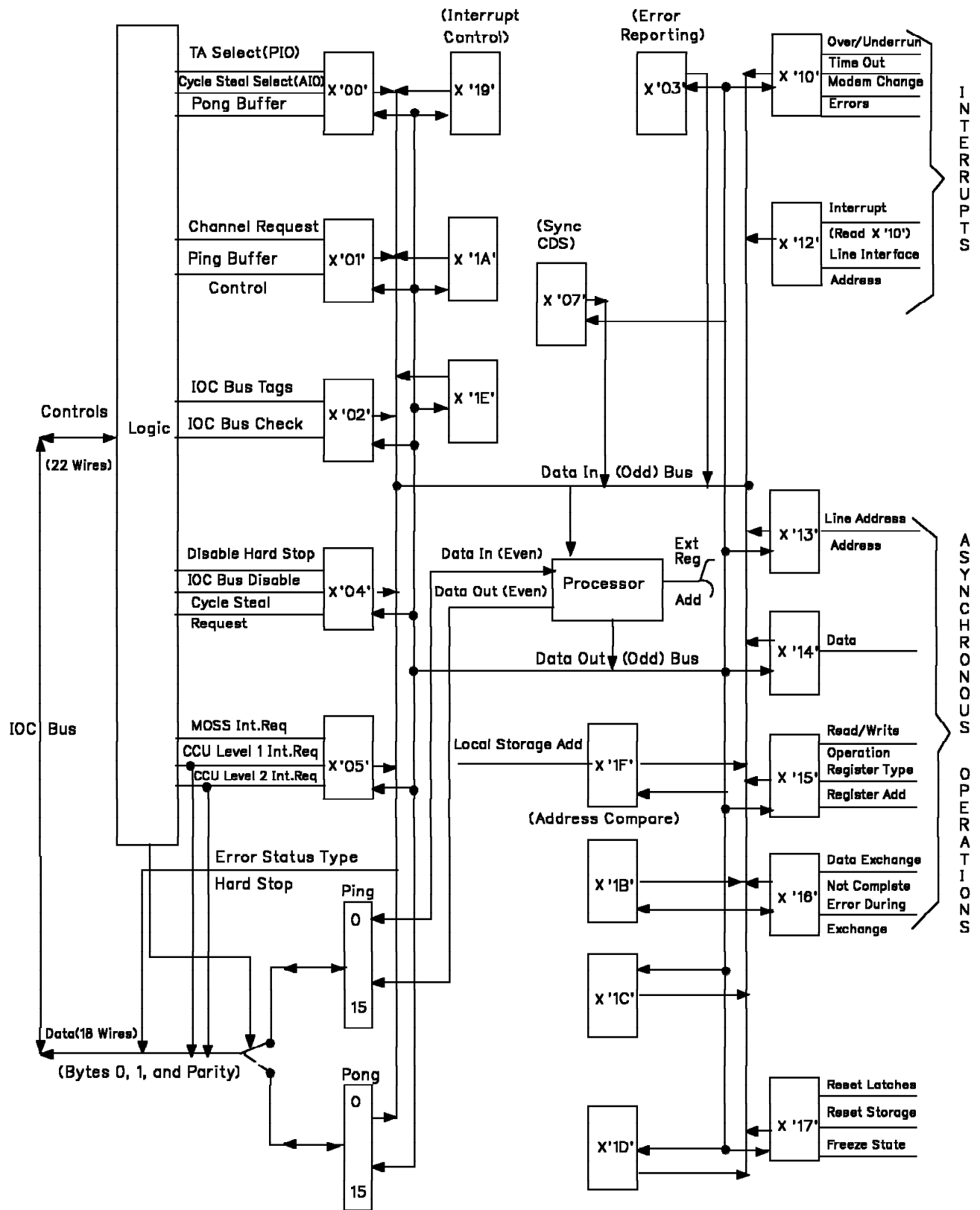

CCU/CSP Register Use

The CSP external registers are used by the following operations:

- Program-initiated operation (PIO)
- Adapter-initiated operation (AIO)
- Interrupt operation.

Ping/Pong Buffers

Two half-word registers, called the ping and pong buffers, located in the local storage, are alternately connected to the IOC bus in flip/flop mode.

They are used for transferring commands, data, and control words between the IOC bus and the CSP.

Switching from one buffer to the other is controlled by the IOC logic.

Processor Characteristics

Program Levels The interrupts are raised by the microcode (all levels) or by hardware (levels 0, 1, and 2). Levels 0 through 3 can be masked by the microcode.

Level	Function
0	Error handling and address compare
1	CCU instruction processing
2	FESL interrupt processing
3	Queue and command processing
4	Not used
5	Not used
6	Not used
7	Timer control and disconnect stop initialization

Clock An oscillator on the CSC card provides the 49.152 MHz square wave to generate the scanner processor's clock. The 49.152 MHz is also sent to the FES and FESA for clock generation. Two other clocks are generated in the CSP:

- A 100 ms clock used for timer purposes
- A 15.4 μ s clock used to refresh the storage.

Error Management

Internal CSP errors detected by the CSP hardware cause a CSP hardstop. Two bytes of status information are presented by the CSP either to the CCU control program (NCP) or to the MOSS after the hardstop condition is detected.

Hardstop A hardstop condition is handled by the CSP hardware as follows:

1. A permanent cycle steal request is forced internally to the CSP processor, preventing any cycle steal operation.

Cycle steal having the highest priority with CSP storage, the CSP microcode processing stops, but the CSP clocks keep running.

- A level 1 interrupt request is presented to the CCU control program (NCP) if the CSP is in 'Connect' mode.

- A level 4 interrupt request is presented to the MOSS processor control program if the CSP is in 'Disconnect' mode.
2. The CCU control program (NCP) responds to its level 1 interrupt request by sending a 'get error status' command, as long as the CSP which has raised the the level 1 is found.
The CSP then sends the two bytes of 'error status type hardstop' if the CSP clocks are not stopped by the hardstop condition.
 3. The MOSS control program responds to its level 4 interrupt request by sending a 'get command completion' command. The CSP then sends the two bytes of 'MOSS command completion' if the CSP clocks are not stopped by the hardstop condition. Then the MOSS control program sends a 'get error status' command to which the CSP responds with the two bytes of 'error status type hardstop'.

The error status type hardstop does not transit through the ping/pong buffers, but is directly presented on the IOC bus data bytes.

The hardstop is reset from the CCU or the MOSS via a programmed reset command or a general reset.

Scanner States

The state of a scanner is shown on the console display (refer to the *3745 Service Functions*, SY33-2069). The state may be:

- Inoperative** The scanner is inoperative when it is not in any other state.
- Initialized** The scanner is initialized when the CSP is loaded with the microcode and the FESL storage is initialized to all zeros. There is no operation with the control program.
- Connected** The scanner is connected when it runs under control of the control program. Errors on CCU I/O instructions are reported to the control program, and errors on MOSS I/O instructions to the MOSS.

- Disconnected** The scanner is disconnected when it does not run under control of the control program but under control of the MOSS microcode.

Only MOSS I/O instructions are executed. Any instructions from the CCU are not answered.

When disconnected from the control program, the scanner may be:

Running (disconnected-go)

The scanner can be in this state while being IMLed, dumped, or being fixed using the TSS services.

Stopped (disconnected-stop)

The microcode continues to react to the MOSS instructions. The scanner can be in this state while being fixed using the TSS services.

Any errors are reported to the MOSS.

The scanner may be disconnected by the :

- Operator when entering a service command (stop or address compare with the stop option selected, for example)
- Microcode when certain errors are detected (a CCU interrupt level 1 is requested with the disconnect indication).

CSP Reset

Resetting a CSP can be done by:

- A specific power ON reset (POR) line coming from the power box for each CSP.
- A programmed reset PIO for each CSP, sent by the control program or by the TSS services (operator console).

In these two cases, the state of the CSP is reset. In case of individual POR, the MOSS microcode waits 12 s, before attempting to start an operation with the CSP again.

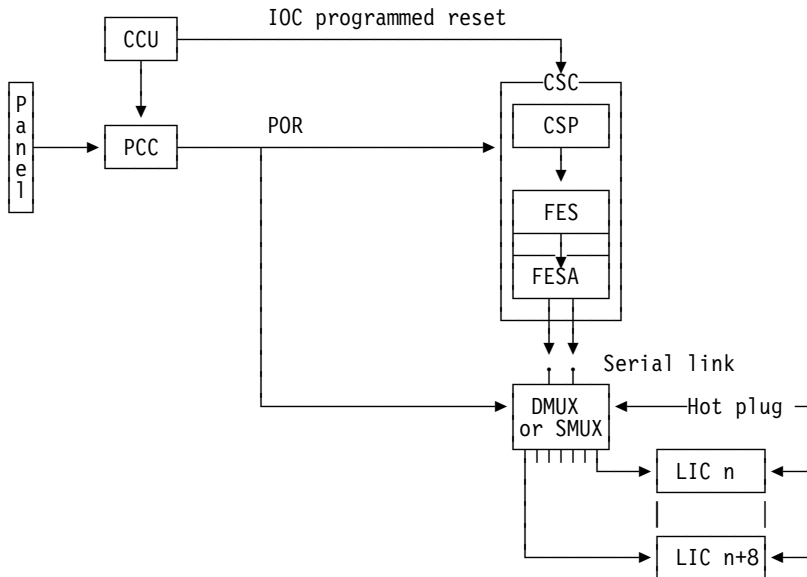

Power ON Reset

When the CCU activates the line POR (on the IOC bus) during a general IPL or a power ON, the register X'04' bit 2 is set in every scanner, which:

1. Forces a CSP interrupt level 0.
2. Starts microcode execution at address 0, initiating the following functions:
 - General reset with a reset of the CSP storage
 - Start of ROS diagnostics
 - Reset of clocks
 - Reset of external registers X'03' (CSP error) and X'08' (error indicators/bad parity generator).
3. Disables the IOC bus and reset the FESL (by setting ON the reset adapter). The LICs and ICFs are reset at the same time.

Programmed Reset

The control program can reset a specific scanner by sending a write command in PIO mode, with the operation code 'programmed reset', along with the scanner address. This command is latched on external register X'04' bit 1, then, the selected scanner:

1. Disables the hardstop (X'04' bit 3 ON).
2. Starts the microcode at level 0 address 0, with a jump to the end of diagnostics to wait for a dump or re-IML.
3. Resets the interrupt requests to the MOSS and CCU (X'05' bits 0 and 2 ON).

4. Stops the connected FESL (FESL status: freeze) but the storages of the CSP and FESL are not reset and the CSP storage can be dumped.

The 'reset to adapter' is activated by the microcode, rising the X'04' bit 2 during a few instructions.

Scanner Commands

The following commands may be used from the operator console to modify the scanner state.

Current State	Possible Scanner Commands	Resulting State
Connected	Stop Reset Dump IML	Disconnected/stop Reset Reset Initialized
Disconnected/go	Stop Reset Dump IML	Disconnected/stop Reset Reset Initialized
Disconnected/stop	Start Reset Dump IML	Disconnected/go Reset Reset Initialized
Reset or Unknown mode	Reset Dump IML	Reset Reset Initialized
Initialized	Stop Connect Reset Dump IML	Disconnected/stop Connected Reset Reset Initialized
Inoperative	Reset Dump IML	Reset Reset Initialized

Scanner Status After the IML

At the end of scanner IML it is possible to get from the CCU storage, the status of the scanners associated with their mailbox.

The 16-byte mailboxes are located from CCU storage address 3F8000.

The status of the scanners just IMLed are in the last two bytes of the mailbox. These values must be displayed before any mailbox exchange between the CCU storage and the corresponding scanner (for example: CCU functions).

Below are the possible statuses of the scanner after an IML:

Values	Description
X'nnFF'	No answer from scanner following the MOSS command 'nn'
X'C900'	Normal status IML OK
X'C904'	Adapter interface check
X'C908'	FES error reporting path check
X'C90F'	MUX address different between CDF and values from the scanner
X'C910'	FES internal error
X'C920'	MUX error
X'C940'	FES failing to answer
X'C980'	AIO error
X'C9F0'	Bypass bit different between CDF and values from the scanner

Figure 4-2. Values of the Last Two Bytes of the Mailboxes after IML

Front-End Scanner (FES)

The front-end scanner (FES) is an adapter of the CSP. It is part of the communication scanner card (CSC). Its scanning circuit supports, under the control of the CSP, a wide range of protocols and line interfaces.

Throughput

The FES maximum throughput varies from 256 kbps (for one line attached), to 307.2 kbps (for 32 lines at 9600 bps distributed over eight LICs).

The throughput is spread over the LICs up to the last one enabled on the LIC unit. If only one LIC is enabled, all the throughput is devoted to that LIC.

Data Flow

As shown on the next data flow, the FES:

- (A) Controls the FES timing, the exchange with the CSP, and the RAM operation.
- (B) Controls the transfer of characters between the front-end and the CSP.
- (C) Handles the data halfwords coming from or going to the control storage.
- (D) Provides cycle steal control for the CSP.
- (E) Interrupts the CSP on level 2 for buffer and data management, and for error reporting.
- (F) Serializes/deserializes the data bits transmitted to or received from the FESA.
- (G) Provides line services related to link protocol and modem control by managing the LICs via the FESA and the serial link.

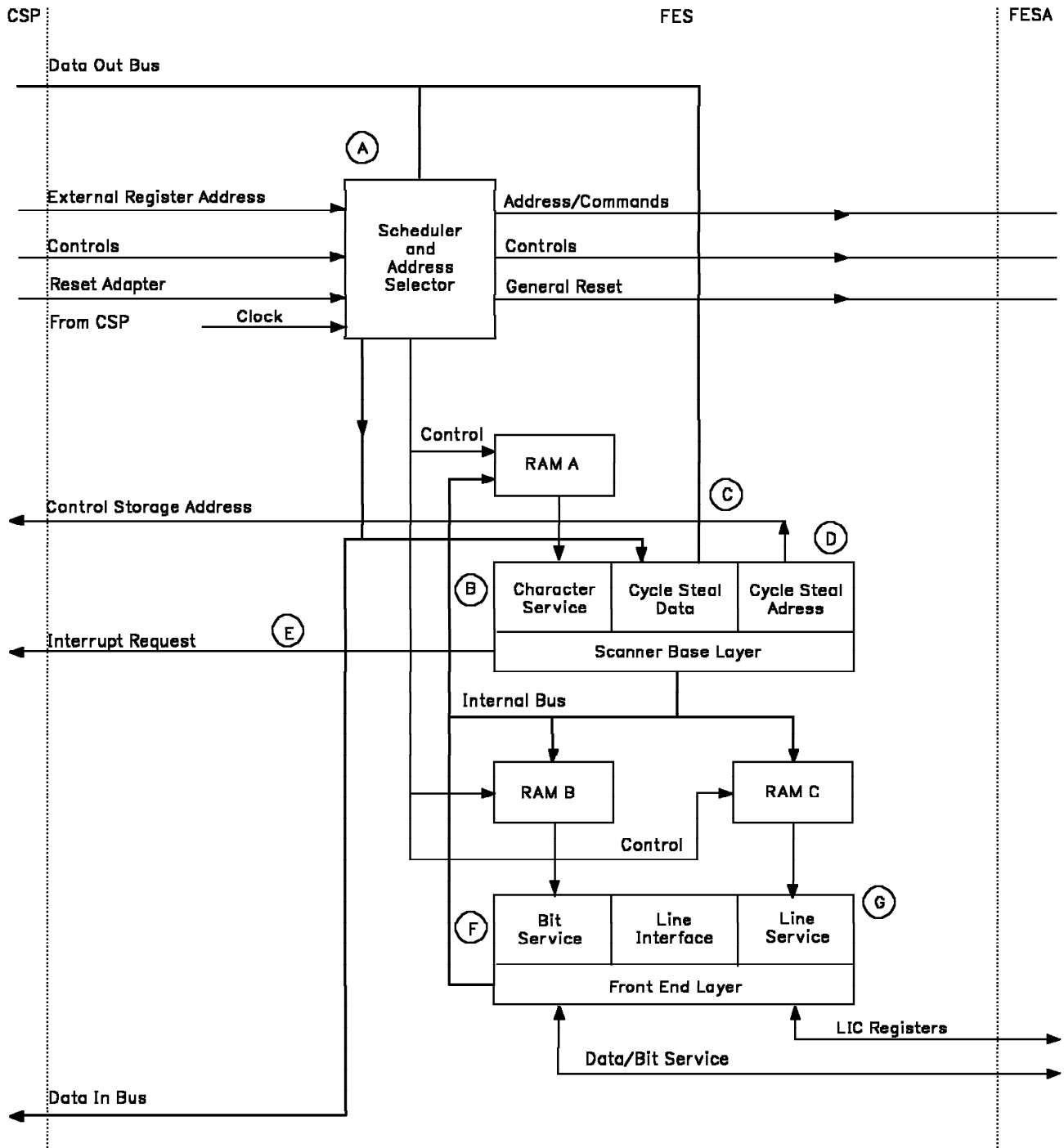

Storages

The FES includes three random access storages (RAMs):

- RAM A for character service
- RAM B for bit service
- RAM C for line service.

These RAMs are used in receive and transmit, and give a total of $4 \times 64 = 256$ halfwords per RAM.

The FES storages can be displayed or altered from the operator console, using the TSS functions.

FESL Reset

The FES (part of the CSC card) can be reset from the CSP by a programmed reset. The FES reset is sent to the FESA to reset:

- The FESA
- The MUXs
- The attached LICs.

FESL Reset Flow

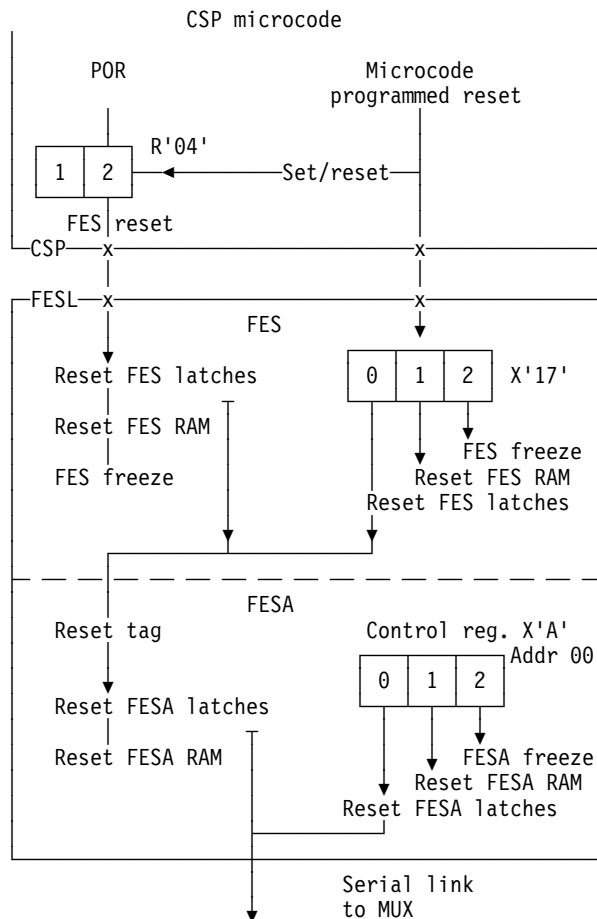

Power ON Reset

The FES 'reset line' signal is driven by CSP R'04' bit 2. This bit is set by the hardware in case of POR, or by the microcode in case of programmed reset. It is reset by the microcode. This 'FES reset' signal:

1. Resets the FES latches and sets the FESA reset tag.
2. Disables the lines between the CSP and the FES.
3. Resets the FES RAMs: all bits are set to zero and the correct parities are written.
4. Stops all scanning (the FES remains in the freeze state after this reset).

The reset tag from FES starts the following sequence in the FESA:

1. Reset FESA latches and set FESA serial link to 'no transmission'.
2. When reset OFF, reset FESA RAMs.

3. Then, set FESA to normal mode.

Programmed Reset

The FESA can also be reset by the microcode by setting bits 0, 1, and 2 of the control register common address X'A' with line address '00'.

- Bit 0 resets FESA latches and sets FESA serial link to 'no transmission'.
- Bit 1 resets FESA RAMs.
- Bit 2 freezes FESA.

Front-End Scanner Adapter (FESA)

The front-end scanner adapter (FESA) is the third part of the CSC card.

The first purpose of the FESA is to convert the FES parallel bus into the serial link bit stream and conversely.

FESA Data Flow

The FESA data flow shows:

- The interconnection of FESA with the two serial link processors (inbound and outbound).
- The FESA to FES interconnection.
- The internal organization around the FESA RAMs to manage the data and control information exchanged by the FES and the serial link.

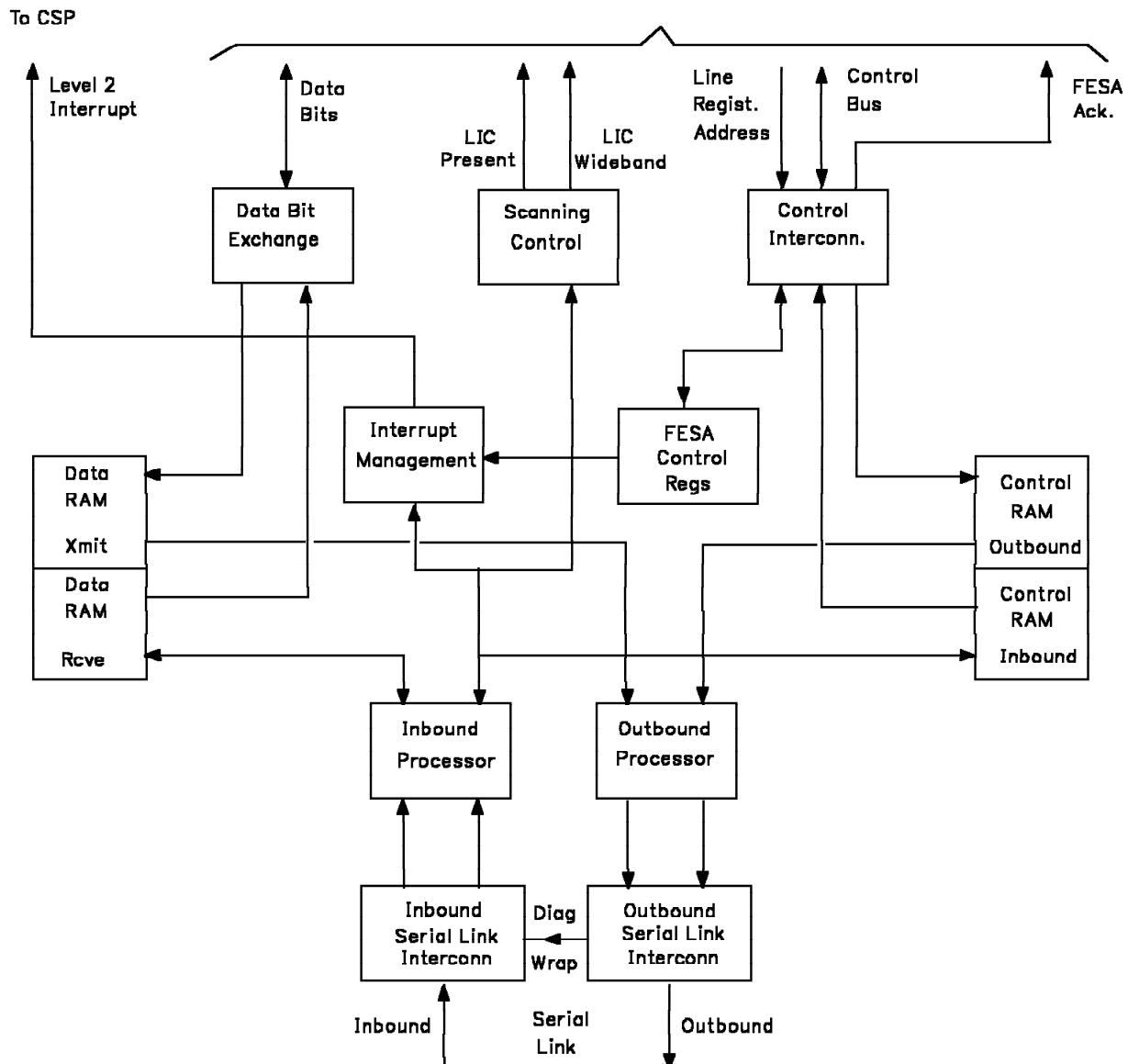

FESA-CSP Interconnection

The FESA level 2 interrupt tag allows the FESA to directly communicate with the CSP.

FESA-Serial Link Interconnection

The FESA is connected to the associated LIC units (through the DMUX/SMUX cards) by means of two twisted pairs:

- One pair for the outgoing frames (outbound serial link)
- One pair for the incoming frames (inbound serial link).

FESA Description

The FESA converts FES parallel data into a serial bit stream.

Three RAMs are implemented in the FESA to be used as LIC/MUX registers (inbound and outbound control RAMs), and to be used as data buffer during the process (data RAM).

- The outbound control RAM stores the FES and microcode commands to MUX and LICs (set mode) before being carried by the proper slots of the outgoing frames sent on the outbound serial link.
- The inbound control RAM stores the MUX and LIC registers information sent by the LICs, and transferred to the CSP on microcode request.
- During the transmit and receive process, the data RAM stores data and control bits for each line. The FESA uses the RAM as a working area to serialize and assemble the data bursts.

Each RAM is divided into 32 areas (one area per line). In the control RAMs, each area contains the line register information.

The RAMs are time-shared by the FES and the two serial link interconnections (inbound and outbound).

The FESA synchronizes the various RAM requests. It monitors the FES RAM access requests and monitors the outbound and inbound serial link frames.

RAMs can be displayed or altered, using the TSS functions.

In addition, the FESA:

- Controls the FES scanning mechanism by generating the LIC present and the LIC wideband patterns
- Controls the modem-in leads according to parameters loaded by microcode in the FESA control RAMs
- Detects and reports the errors occurring on the LIC, the MUX, the serial link, or the FESA itself
- Generates the FESA level 2 interrupts to the CSP microcode to report DCE management events or errors
- Performs the diagnostic functions to test the FESL card, the DMUX or SMUX card and the serial link
- Synchronizes the frame and superframe with the MUXs.

FESA RAM Organization

There are three RAMs in the FESA:

- Two 1-Kbyte control RAMs
- One data RAM of 128 halfwords.

FESA Inbound and Outbound Control RAMs

The control RAMs contain all the information required by the FES and the microcode to manage the lines.: The control RAMs are divided into 32 areas. Each area stores the contents of the MUX/LIC registers associated to one line.

FESA Inbound/Outbound RAMs Addressing

The CSP microcode uses two CSP external registers (X'13' and X'15') to access the outbound and inbound RAMs,

The FESA external registers are located in the outbound and inbound RAMs. The following tables show the bits of registers X'13' and X'15' used to access the FESA inbound and outbound RAMs.

X'13': Line Interface Address

Bits	Functions
0 0	Not used, always 00
. . x x x	Card address
. x x . .	Line address
. Z	See 'FESA inbound/outbound RAM layout'

X'15': Asynchronous Operation Command

Bits	Functions
x	OFF = read, ON = write
. x x	External
. . . I RR . .	See 'FESA Inbound/Outbound RAM layout'

Local Store 6 (CHHITMIO Input)

Bits	Functions
x	OFF = read, ON = write
. . x	OFF = outbound RAM, ON = inbound RAM
. . . I RREZ	See 'FESA Inbound/Outbound RAM Layout'

FESA Inbound/Outbound RAM Layout FESA control register bit 5, controls the type of operation:

- OFF** Write or output operation
- ON** Read or input operation.

Bit Decoding E I Z R R	Write (FESA ctrl reg bit 5=0) Outbound RAM	Read (FESA ctrl reg bit 5=1) Inbound RAM
0 0 0 0 0	Not used	Not used
0 0 0 0 1	Modem out	Driver check pattern
0 0 0 1 0	Line control	Line control
0 0 0 1 1	Driver check mask	Clock failure timer
0 0 1 0 0	FESA modem control	Modem in
0 0 1 0 1	RFS parameters	RFS work timer
0 0 1 1 0	Wrap control	Wrap ctrl/ cable id
0 0 1 1 1	LIC clock mode	LIC card ID/clock mode
0 1 0 0 0	Receive interrupt control	Receive interrupt stack
0 1 0 0 1	Xmit interrupt control	Xmit interrupt stack
0 1 0 1 0	FESA/MUX/LIC registers (See note)	FESA/MUX/LIC registers (See note)
0 1 0 1 1	Not used, FES diag	Not used, FES diag
0 1 1 0 0	DSR/RI parameters	DSR/RI work timer
0 1 1 0 1	RLSD parameters	RFS/TI drop w.rlsd
0 1 1 1 0	ICF RAM 4C	ICF RAM 4C
0 1 1 1 1	Not used, FES diag	Not used, FES diag

Note: These registers are called 'FESA general registers'. General register '00' is dedicated to line 0, general register '01' is dedicated to line 1, and so on. To extend FESA/MUX/LIC register addressing, the microcode sets the FESA control register with the external register address bit ON (E).

Bit Decoding E I Z R R	Write (FESA ctrl reg bit 5=0) Outbound RAM	Read (FESA ctrl reg bit 5=1) Inbound RAM
1 0 0 1 1	Not used	Line error register
1 0 1 0 0	SDF	SDF
1 0 1 0 1	Control SDF/burst size	Control SDF
1 0 1 1 0	PDF	PDF
1 0 1 1 1	Control PDF	Control PDF
1 1 0 0 0	Line diagnostic register	Line diagnostic register
1 1 0 0 1	Logical address	Physical add./EC number
1 1 0 1 0	Not used, FESA/MUX reg	Not used
1 1 0 1 1	Not used, FES diag	Not used FES diag
1 1 1 0 0	ICF RAM 4D1	ICF RAM 4D1
1 1 1 0 1	ICF RAM 4D2	ICF RAM 4D2
1 1 1 1 0	Not used	Modem-in immediate
1 1 1 1 1	Not used FES diag	Not used FES diag

FESA Data RAM The FESA data RAM is divided into 32 areas (one area per line) of four halfwords each:

Halfword	Byte 0 (Even address)	Byte 1 (Odd address)
0	Receive SDF	Receive control
1	Receive PDF 0	(Not used)
2	Receive PDF 1	(Not used)
3	Transmit SDF	Transmit control 1
4	Transmit PDF	Transmit control 2

The data RAM is shared by the inbound and outbound serial link data processors, and by the FES for data exchange.

FESA-FES Interconnection Management

LIC Enabled Leads The LIC enabled leads are used by the microcode to dynamically modify the FES scanning range. A LIC is enabled when at least one line of that LIC is enabled (line control register bit 1 ON).: The LIC is disabled when all lines of the LIC are in the disabled state (line control register bit 1 OFF in all lines.)

The FESA builds the LIC enabled pattern by monitoring the line enabled information sent by the LICs over the inbound serial link.

Note: Disabled LICs are seen as not present by the FES and, consequently, these LICs are not scanned in order to accept higher throughput on remaining actives lines. The 'LIC 0 present' is not given to the FES, which always assumes that the first LIC is present, as a minimum configuration.

The FESA makes no difference between the LIC's physical and logical addresses:

- For the FESA, the position of a LIC is determined by the slots occupied by this LIC in the inbound frame.
- .When a line is enabled by the microcode, and presents 'line enabled' to the FESA, the FESA does not set 'LIC present' immediately. Instead, it sets line control register bit 6 in the inbound control RAM ('line enabled remembrance'), and waits for the next 'line enabled' (at next superframe), to set line control register bit 1, and update 'LIC present'.
- The 'LIC enabled' pattern can be read by the microcode, by successively addressing the two corresponding registers in the FESA.

Note: For example, assuming a LIC plugged in physical position 0 on the LIC board:

- If this LIC receives logical address 7, it occupies the slots assigned to LIC number 7 and will be seen as LIC in physical position 7 by the FESA and FES.
- If this LIC has no line enabled, it will not be scanned.

LIC Wideband Leads The LIC wideband information is used by the FES to scan wideband lines four times faster than non-wideband lines.

DCE Lead Management

Modem-in: The modem-in information coming from the lines, is stored in the inbound control RAM address X'1E' of each line. When a line is scanned by the FES, modem-in is passed by the FESA to the FES for DCE change detection.

To perform the modem-in control, the FESA keeps the confirmed modem-in patterns in the inbound control RAM (Address X'04') for the FES requests, and monitors.

Control of DSR, RI, and RLSD: For any line, the FESA is able to confirm the changes of any of these signals by using specific timers. DSR, RI, and RLSD are confirmed for both raising and falling edges.

Integration of I (X.21) is performed for I drop only (I going ON is immediately reported to FES in any case).

A different timer starts each time the associated signal switches. The change is confirmed when the time out is reached.

The confirmation delay is specified, for each signal, in a 3-bit parameter field, loaded by the microcode, in the outbound control RAM.

Parameter Value	Time out
0 0 0	0 (Immediate reporting)
0 0 1	1 ms
0 1 0	4 ms
0 1 1	16 ms
1 0 0	32 ms
1 0 1	64 ms
1 1 0	128 ms
1 1 1 (RI, I, or RLSD)	256 ms
1 1 1 (DSR drop)	10 s
1 1 1 (DSR raising)	Parameter value loaded elsewhere for RI

Control of RFS: Only the drop of RFS is controlled. The FESA monitors the drop on microcode request, in the following way: The FESA controls the drop of RFS when the microcode loads the RFS drop time out value in the outbound control RAM, along with the clock select bit which chooses the decrement clock.

Outbound control RAM address: X'05' (00101)

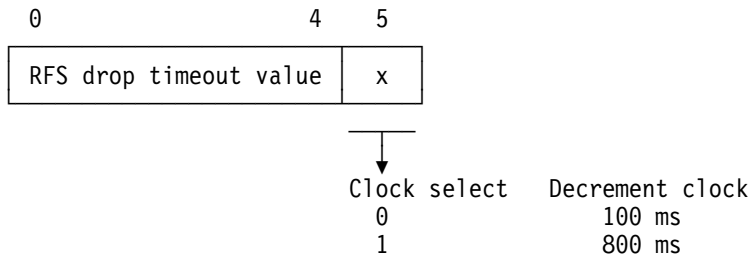

Control of TI: The immediate value of TI is passed by the FESA to the FES in the modem-in field for DCE change detection. When TI is masked in the FES, the FESA memorizes (for microcode information) that TI has raised, by setting bit TI 'remembrance' (saved in the inbound control RAM). TI remembrance is reset by the microcode.

Confirmation of Clear (X.21): The 16-bit time confirmation of the X.21 steady states is performed in the LIC. The only X.21 steady state confirmed by the FESA is 'clear' when the protocol requires a 10 ms confirmation instead of the 16-bit time.

Modem-out: The modem-out pattern coming from the FES, is stored by the FESA in the outbound control RAM. The FESA also controls the integrity of the modem-out patterns up to the LICs output (LIC driver check).

Serial Link (SL)

All information between the LIC board and the scanner unit is exchanged via the TSS serial link in two modes:

- Inbound mode from DMUX/SMUX to FESA.

All LIC information is stacked in FESA RAM and is available for the FES synchronously or asynchronously.

- The LICs give the data received from transmission lines to the FESA.
- The FESA reads the registers from the MUXs or LICs.

- Outbound mode from FESA to DMUX/SMUX.

- The FESA gives to the LICs the data to transmit.
- The FESA writes into the MUXs or LICs registers.

Connection to LIC Type 5 and LIC Type 6

Information exchange between the scanner and LIC type 5 and LIC type 6 DCEs is performed via a serial link, which consists in:

Inbound link From LIC to scanner

Outbound link From scanner to LIC.

This information is carried in a frame structure.

Frames: A frame is a sequence of 32 double slots (data + control).



A superframe is defined as a sequence of 32 frames. A corresponding delimiter is put in control slots of frame 31, to signal the end of a superframe.

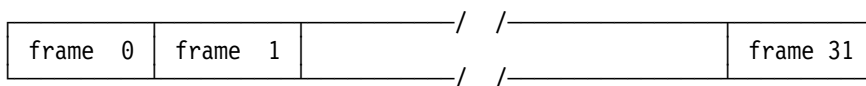

Slots: A double slot is made of:

- A data slot
- A control slot.

A slot is an eight-bit element of information.

Data Slots: Data exchange between the scanner and the DCE is performed on a request/answer basis, in order to enslave the serial link data speed to the DCE transmit and receive clocks.

The transmit and data slots carried by the serial outbound and inbound links, contain bursts of data or are empty.

Up to five data bits can be sent or received in a data burst.

A data delimiter indicates the actual length of a data burst.

An empty data slot is ignored by the LIC and RTS remains at the previous state.

Control Slots: Control slots are used by the SMUX or DTE (LIC) registers, according to the frame number: inside a superframe, control slots of all even frames are dedicated to the V.24 registers.

Notes:

1. One double slot is used for DCEs working at speeds less than 20 kbps.
2. Four double slots are needed for DCEs working at 56 kbps.
3. A maximum of four DCEs working at 56 kbps can be attached to a same scanner.
4. When an even (resp. odd) DCE cassette address is used by a 56 kbps DCE, the odd (resp. even) corresponding address must be left free.

Double Multiplexer Card (DMUX)

For LIC types 1 to 4 (DTE function only).

DMUX Functions

The two MUXs (on the DMUX card) convert the serial link bit stream coming from the FES into the LICs bit stream.

On the serial link side the DMUX:

- Monitors the frames coming from the FESA.
- Retrieves and decodes the serial link bit stream encoded information (code Manchester).
- Detects the frame sync and transmits it to the LICs.
- Copies in the proper register the incoming information addressed to the DMUX.

On the LIC bus side the DMUX:

- Monitors the serial information coming from the LICs.
- Transmits it to the FESA via the serial link after Manchester encoding.
- Sends control data stored in DMUX registers to FESA.

In addition the DMUX provides:

- A bit timing synchronized from the received data (PLO function)
- Three clocks for LIC internal clock function (ICF)
- Three functional clocks for LICs synchronized on the outbound data flow
- Two clocks for clock failure detection function assumed by the LIC
- Eight LIC reset commands (to isolate any LIC from the inbound data flow)
- DMUX physical address, machine frame configuration, and DMUX EC number information to the FESA
- Error detection
- Diagnostic facilities.

MUX 1 or 2 Data Flow

There are two multiplexors (MUX) within a DMUX card. Each MUX attaches to one serial link.

The data flow of the two MUXs is identical and is as follow:

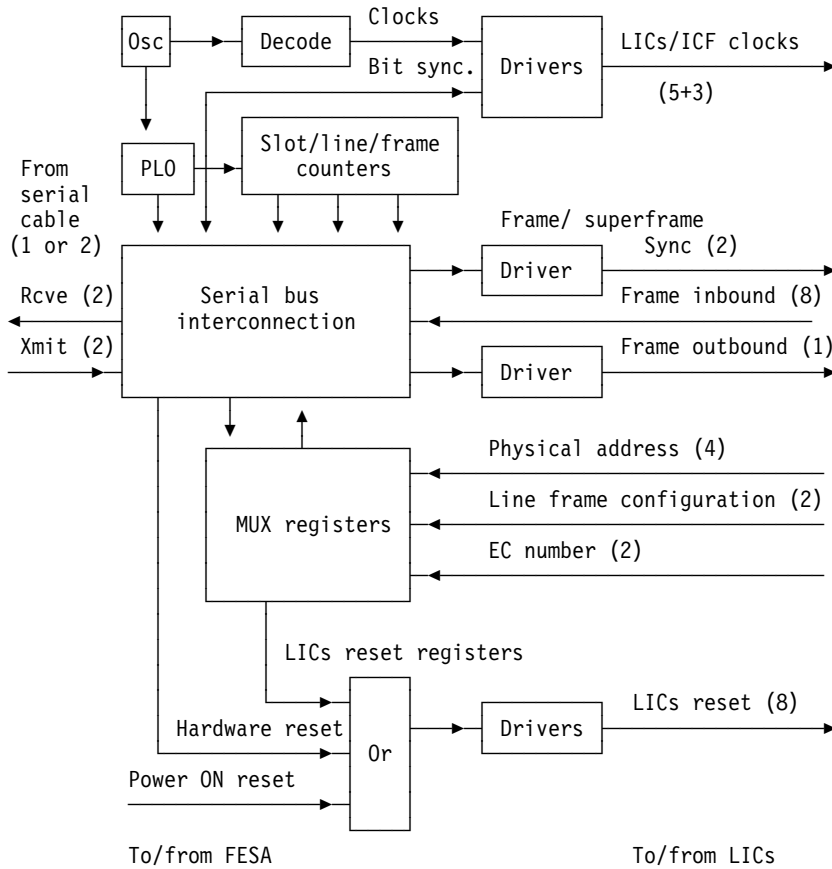

Note: Numbers in parentheses are the number of leads.

DMUX Functional Description

Only one or both of the two MUXs of the DMUX card can be used depending on connecting to one or two scanners.

Connection to one scanner

In this 'MUX extended configuration', up to 8 LICs (physical address 0 to 7) are connected to the scanner.

The 'Cable 2 Present' bit is set OFF in the DMUX card

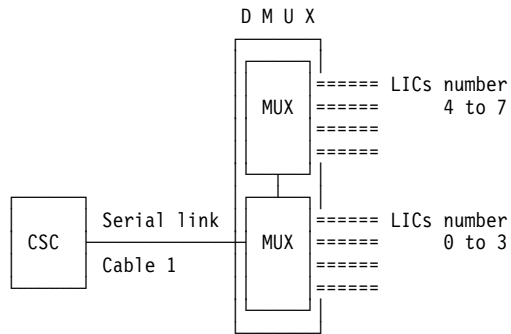

Connection to two scanners

In this 'Not extended configuration', up to 4 LICs (physical addresses 0 to 3, or 4 to 7) are connected to each scanner

The 'Cable 2 Present' bit is set ON in the DMUX card

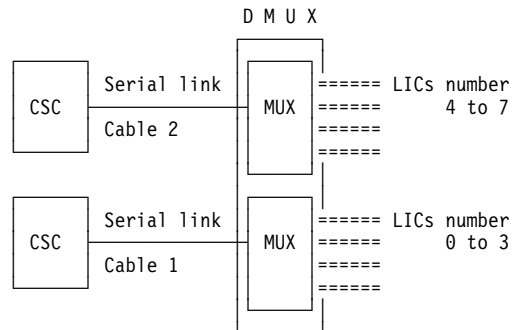

DMUX Reset

The DMUX card and, consequently, the two MUXs can be reset:

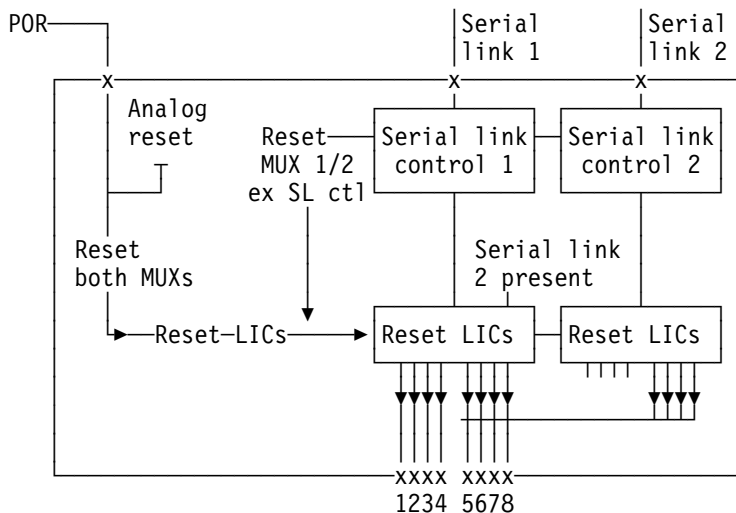

1. A POR line coming from the power supply (one line for two DMUX cards). In that case a MUX reset is done and a reset LIC is sent to each associated LIC.
2. The DMUX card being **hot pluggable**, an analog reset circuit allows to perform the reset as for a POR line.
3. If there is a detection of 'no transmission' on the serial link, the MUX itself generates a reset MUX, except on the serial link control part and generates a reset on the associated LICs (extend mode or not.)

LIC Reset LIC reset is done either by the selective reset LIC line coming from the MUX or by an analog reset circuit on the LIC itself in case of hot plugging. A selective reset can be done by the microcode through the serial link by selecting the appropriate bit in the LIC reset register of the MUX.

The reset allows to isolate the LIC from the MUX (via the LIC bus), and from the attached lines.

DMUX Hot Plugging

Bottom connectors with several level of indentations and an analogic power ON reset delay provide the required power sequences.

Single Multiplexer Card (SMUXA/B)

For LIC types 5 and 6 (DTE plus DCE functions):

- The SMUXA is associated to the lower board.
- The SMUXB is associated to the upper board.

SMUXA and SMUXB are slightly different in packaging (cable connector), but are functionally identical; therefore, SMUXA or SMUXB will be referred to as SMUX cards.

SMUX Functions

The SMUX cards convert the serial Manchester-encoded bit stream into the LIC serial outbound bit stream and, conversely, the serial inbound bit stream from the LICs into serial Manchester-encoded bit stream for the FES.

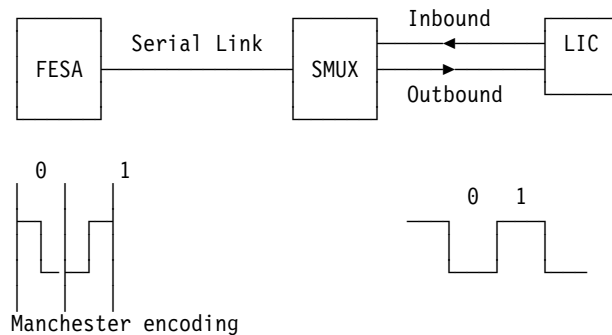

On the serial link side:

- Monitors the frames coming from the FESA.
- Retrieves and decodes the Manchester-encoded information.
- Detects the frame synchronization pattern and transmits sync pulses to the LICs.
- Loads the information devoted to the SMUX into the proper register.

On the LIC bus side:

- Monitors the serial information coming from the LICs.
- Transmits it to the FESA after Manchester-encoding.
- Sends the control information from the SMUX registers to the FESA.

In addition the SMUX provides:

- A bit timing synchronized from the received data (PLO function)
- Two functional clock signals to the LICs (synchronized from the outbound data flow)
- Eight LIC reset commands (to isolate any LIC from the inbound data flow)
- SMUX physical address, machine frame configuration, SMUX EC number and 'LIC5/6 present' indication
- Error detection
- Diagnostic facilities
- 1 MHz clock signal to the LICs for PKD operation
- Four binary coded bits to LIC type 5 for transmit level setting (see transmit level hereafter).

Transmit Level

The transmit level is country-dependent.

The correct transmit level for a given country must be set at installation time by the CE each SMUX card by means of four switches (0 to -15 dBm).

SMUX

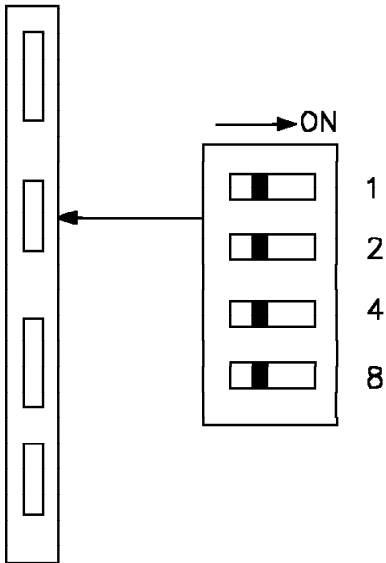

At IML, those switch values are read into each corresponding LIC type 5 non-volatile RAM. However, if one of these transmit levels has to be slightly modified in the field (for example to compensate for line impairments), it can be modified from the PKD by the CE.

Card Replacement In case of SMUX replacement, carefully note down the previous SMUX switch settings or use the following table to determine the maximum authorized transmit level in your country.

Country (non-switched lines)	Transmit level
AG and A/PG (generally)	0
Australia	-13
Canada	0
Chile	-6
Denmark	-10
EMEA (generally)	-6
Finland	-10
France	-15

Country (non-switched lines)	Transmit level
Greece	0
Hong-Kong	- 9
Iceland	-10
Ireland	0
Italy	-10
Japan	-15
Sweden	-10
UK	-13

SMUX Data Flow

The data flow of the SMUX A/B is as follows:

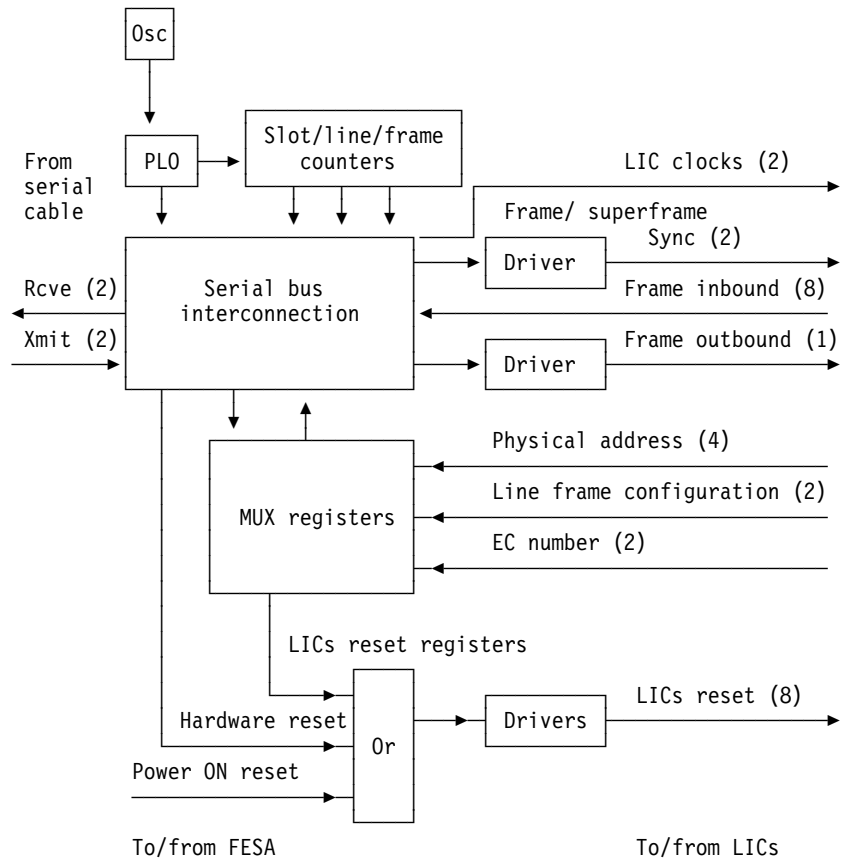

Note: Numbers in parentheses are the number of leads.

SMUX Functional Description

Although SMUXB might not be used, SMUXA and SMUXB are permanently installed on both LIB2s.

If a serial link cable is connected to a SMUXB, it works exactly as a SMUXA.

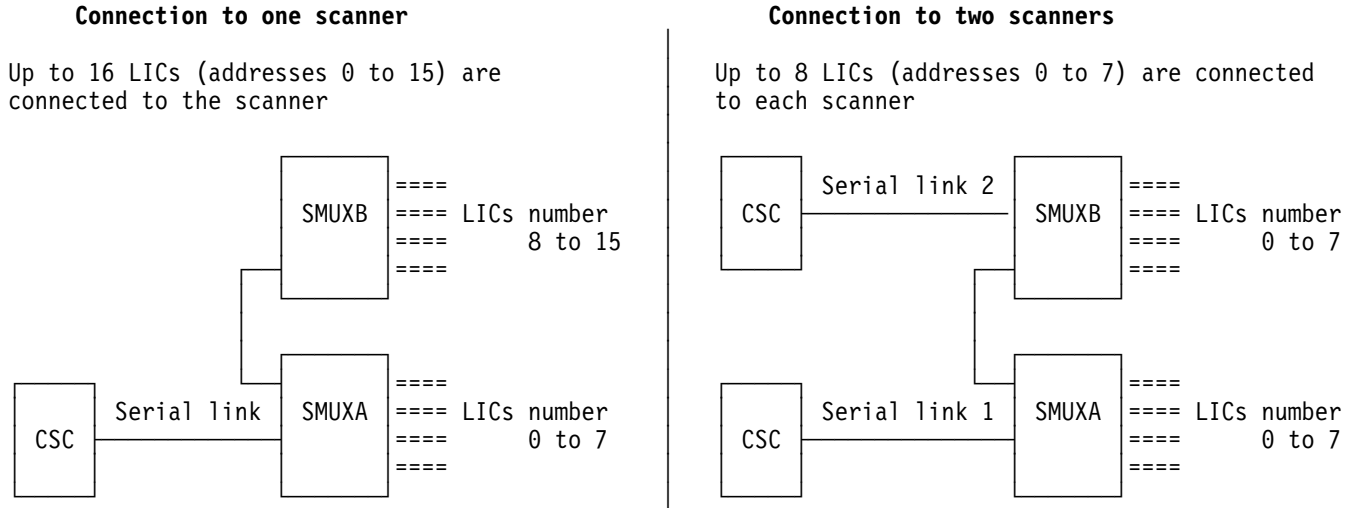

SMUX Reset

SMUX A and B cards can be reset by either of the following ways:

- By the POR line coming from the power supply. The POR line acts on both SMUX A and B cards. Both SMUX A and B are reset and send a 'LIC reset' to each associated LICs.
- By an 'analog reset' when a SMUX card is hot-plugged.
- When absence of signal is detected on the outbound serial link.

LIC Reset

LIC reset is done either by the 'selective reset line' coming from the SMUX or by an analog reset circuit when the LIC is hot-plugged.

Selective reset can be done:

- Either by microcode through the serial link
- Or by selecting the appropriate bit in the LIC registers of the SMUX.

SMUX Hot Plugging

Bottom connectors with several levels of indentations and an analogic power ON reset delay provide the required power sequences.

LIC Types 1 to 4 Cards

The LIC types 1 to 4 provide DTE function only. They connect the DMUX card to various types of DCEs or direct-attached DTEs.

There are four types of LICs according to the CCITT interfaces.

LIC1s to LIC4s to DMUX interconnection is identical (the number and meaning of bits may however differ according to the type of DCE attachment).

Some LICs require internally generated clock signals for either:

- Low-speed DCE attachment
- Direct attachment to terminals.

The internal clock function (ICF) on the LIC card itself, provides these clock facilities.

Interface Lines

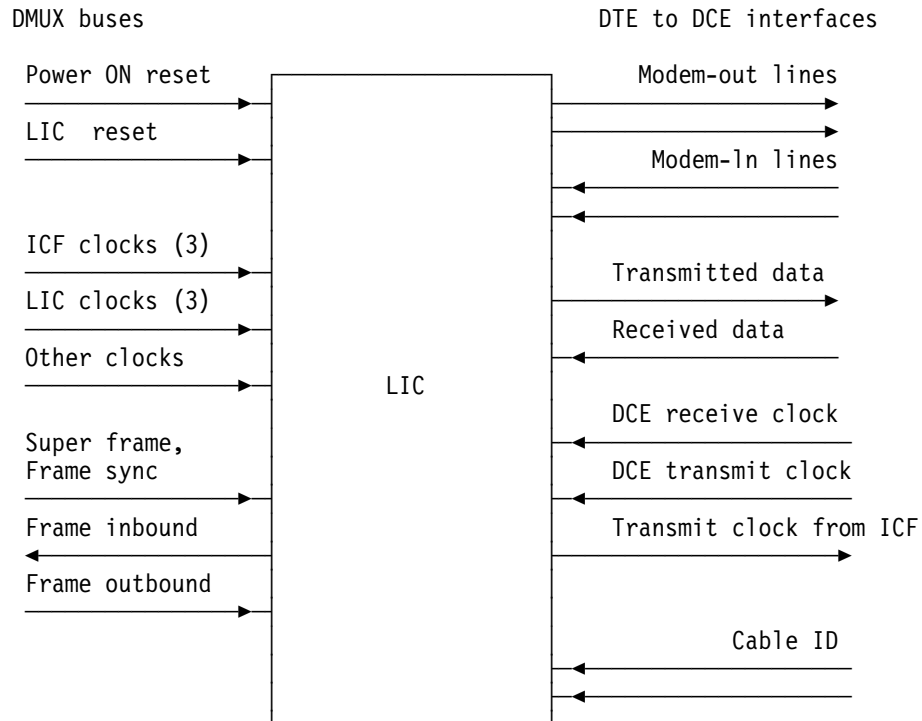

Transmit/Receive Data Mechanism

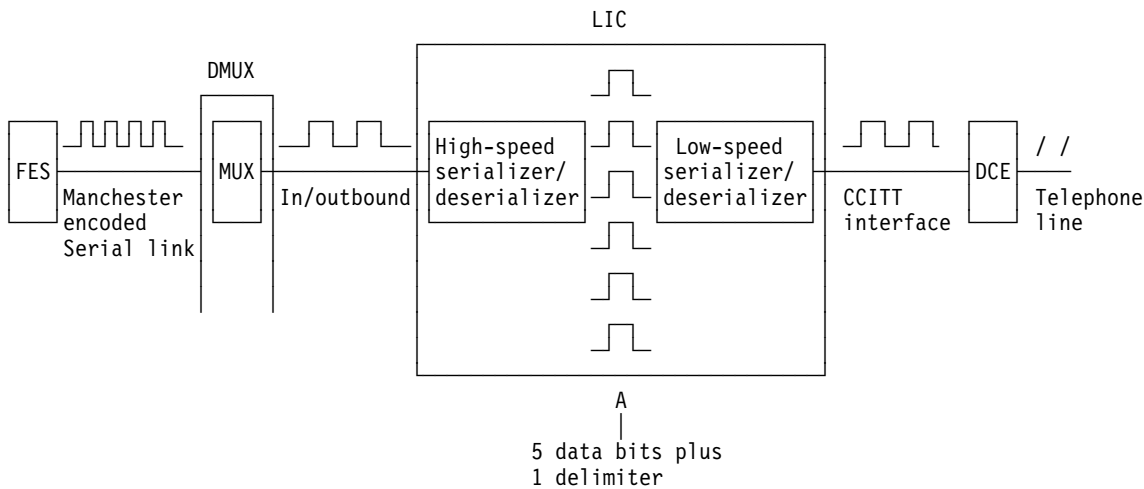

The data is passed from/to the FES to the telecommunication line via the MUX and LIC as shown above.

The LIC communicates with the FES to:

- Request new data to be transmitted (when in transmit mode)
- Signal 'transmit overrun/underrun': 'LIC line error register bit 3' (when in transmit mode)
- Signal 'overrun': 'LIC line error register bit 2' if more than 5 data bits are received between two serial link requests (when in receive mode).

LIC Reset

See also "DMUX Reset" on page 4-37.

The purpose of the LIC reset command is to isolate the LIC from the LIC bus and from the attached lines (DMUX card provides one reset lead per LIC).

- At power ON, all leads are activated during the power ON reset, until the DMUX detects a start pattern from the FESA.
- After power ON, one reset lead may be activated on request, to reset the logic in the corresponding LIC and to disable all the line interface drivers.
 - In the reset state, no information can be exchanged with this LIC.
 - Any command to a LIC in reset state ends with a LIC check at the FES-FESA interconnection.

Line Enable/Disable

When a line is enabled, it accepts read/write operations as well as data transmission/reception and DCE interface handling.

After a LIC reset, all lines are automatically disabled and do not handle any more data transmission/reception nor DCE interface handling.

- On one-line LICs, when the line is disabled (but not in the reset state), it can be written **and** read.
- On four-line LICs:
 - When the four lines are disabled (but not in the reset state), it can be written **but cannot be read**.
 - When at least one line is enabled, it can be written **and** read.

Each LIC (not under reset state) monitors the incoming and outgoing frames to receive and send register information belonging to its lines. This allows the lines, even disabled, to receive commands from the microcode and the FES, and to pass status information to the scanner.

These facilities allow the FESA to:

- Handle the line enabled/disabled bits to generate the LIC present pattern
- Modify the FES scanning and dynamically adapt the FES resources to the line configuration changes, without manual intervention.

For example, assuming a LIC plugged in physical position 0 on the LIC board:

- If this LIC receives logical address 7, it occupies the slots assigned to LIC number 7 and is seen as LIC in physical position 7 by the FESA and FES.
- If this LIC has no line enabled, it will not be scanned.
- See “LIC Enabled Leads” on page 4-31 for the microcode handling of these leads.

Selective Scanning

Selective scanning gives more flexibility for backup configurations using the same scanner, as only the LICs which have at least one line enabled, are scanned.

As a result, the total weight of the LICs which can be installed or connected physically to one scanner may be more than the supported weight of the scanner (100), as long as the total weight of the lines enabled at any time, does not exceed the scanner's supported weight.

Selective scanning enables the customer to install on the same scanner, LICs which are enabled only for one configuration at one time, and LICs which will be enabled only for a second configuration later (the first configuration having to be disabled first).

Selective scanning is managed by the CSP microcode.

Notes:

1. When modifying a configuration containing one or several LIC4s, the scanner must be re-IMLed.
2. No checking is made to verify that a scanner is overloaded.

LIC Logical Addressing Function

LIC logical function allows selective scanning.

In the example of configuration changes hereafter:

- The logical address function allows multi-configuration changes without card plugging or unplugging.

LIC board								
Physical addresses								
	0	1	2	3	4	5	6	7
DMUX Card	LIC A	LIC B	LIC C	LIC D	LIC E	LIC F	LIC G	LIC H
	9.6	256	1.2	1.2	1.2	64	64	9.6
	Line speeds (kbps)							

- The customer may define several configurations without any physical LIC changes. For example:

Physical addresses	0	2	7		
Configuration 1	DMUX card	LIC A	LIC C	LIC H	8 lines at 9.6 kbps 4 lines at 1.2 kbps

Physical addresses	2	3	4	7		
Configuration 2	DMUX card	LIC C	LIC D	LIC E	LIC H	12 lines at 1.2 kbps 4 lines at 9.6 kbps

Physical addresses	0	2	3	6	7		
Configuration 3	DMUX card	LIC A	LIC C	LIC D	LIC G	LIC H	1 line at 64 kbps 8 lines at 9.6 kbps 8 lines at 1.2 kbps

Physical addresses	1		
Configuration 4	DMUX card	LIC B	1 line at 256 kbps

LIC Swap

The logical addressing function implemented in the 3745 LICs, allows LIC address swap.

Supposing two LICs, one plugged at physical address A (LICA) and the other one plugged at physical address H (LICH).

The logical addressing function allows to 'swap' the logical addresses between LICA and LICH. For example, assign logical address A to LICH, and logical address H to LICA.

Before the swap

Physical addresses	0	1	2	3	4	5	6	7	
	DMUX card	LIC A	LIC B	LIC C	LIC D	LIC E	LIC F	LIC G	LIC H
Logical addresses	0	1	2	3	4	5	6	7	

After the swap

Physical addresses	0	1	2	3	4	5	6	7	
	DMUX card	LIC A	LIC B	LIC C	LIC D	LIC E	LIC F	LIC G	LIC H
Logical addresses	'7'	1	2	3	4	5	6	'0'	

After the swap, on the serial link, LICA takes the slots of LICH and LICH takes the slots of LICA.

LIC Address Register Contents

Write mode		Read mode	
Bits	Meaning	Bits	Meaning
0	LIC logical address bit 0	0	LIC wired address bit 0
1	LIC logical address bit 1	1	LIC wired address bit 1
2	LIC logical address bit 2	2	LIC wired address bit 2
3	Enable/disable logical add	3	Not used
4	Not used	4	EC number
5	Not used	5	EC number

LIC Control Register

The LIC control register X'02' bit 1 and bit 3 (Line enable E0 and E1) controls the swapping.

Bits	Meaning
0	High-speed line
1	Line enable E0
2	X.21 CCITT used by FESA 80
3	Line enable E1
4	Not used
5	Transmit bit echo

Enable Clock Mode

Register X'03' bits 4 and 5 select the clock mode. They are OFF after a reset command (that is 00 = diag mode).

There is no clock until the enable clock mode bit is set, except if the LIC detects that the cable ID is a local attach cable.

After the reset the LIC forces the local attach clock mode: 11 (speed given by ICF after reset: 2400 bps).

Transmit Clock Gating by RFS (LICs 1, 2, and 3)

If LIC control register X'02' bit 2 is set for a given line, it allows gating the interface transmit clock by the modem-in lead RFS (despite the clock mode setting).

There is no clock failure reporting if the transmit clock on the interface is stopped because RFS is OFF.

LIC 4 Personalization

There is only one LIC type 4 part number. The LIC type 4A or 4B (personalization) is defined at IML by the microcode.

The LIC 4 'wideband bit', when set, specifies LIC 4A depending on the NCP speed parameter definition at set mode time.

LIC Wideband with Line Speed Higher than 128 kbps

The wideband LIC is scanned four times faster than the non-wideband LIC. The wideband LIC line takes four data slots in the frame.

- With a line speed less than 128 kbps, the four data slots dedicated to the LIC in a frame are sufficient for the four lines attached.
- With a line speed higher than 128 kbps, only one line may be attached to the scanner (the 'high-speed line' bit is set in the control register).

RTS Through DCE or Data Paths

According to the value of modem-out bit 5, the lead RTS of the DCE interface will change with the new modem-out register or at the boundary of transmit data burst as follows:

- RTS through the DCE path:
When modem-out bit 5 is ON, RTS changes according to the modem-out bit 1 sent to the LIC by the FESA in even frames. RTS change occurs as soon as the new modem-out is loaded.
- RTS through the data path:
When modem-out bit 5 is OFF, RTS changes according to the value of bit 0 of the transmit data burst. The RTS change occurs at the boundary of the transmit burst, that is, with the last data bit.

LIC Modem-In Process for Non-X.21 Lines

The LIC sends the modem-in information without any process to the FESA. The FESA then processes this information in order to raise an interrupt to the FES only with confirmed modem-in information.

For more information see "DCE Lead Management" on page 4-32 in the FESA section.

LIC Modem-In Process for X.21 Lines

The LIC performs the confirmation of X.21 steady states by scanning a 16 bits time.

The LIC sends the modem-in information to the FESA and when the state is confirmed after 16-bits count, the 'bit state confirm' of X.21 modem-in register is raised.

An option is provided to the microcode (when register X'06' is ON) to perform a 10 ms confirmation instead of a 16-bits time. In that case, the LIC sends modem-in to the FESA and the FESA itself confirms the state for 'DCE clear' after a 10 ms count, state confirm still being delivered after a 16 bits time for the other three states.

Internal Clock Function (ICF)

ICF Data Flow

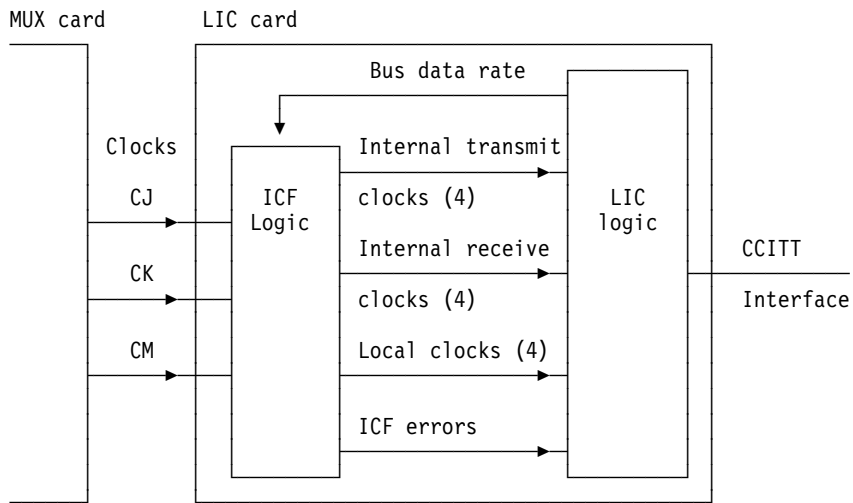

For each line, the transmission speed is selected at initialization by the microcode (set mode depending on NCP generation). The internal clock function (ICF) provides the transmit and/or receive clocks to:

- The LICs and their low-speed non-clocked DCEs.
- The LICs only when their direct-attached terminals use their own clock.
- The LICs and their direct-attached unclocked terminals.

The ICF is not used when a LIC is attached to a clocked DCE.

Depending on the above configurations, the ICF mode can be 'Internal', '3745' or 'External', and the clockings are provided as follows.

Internal Mode

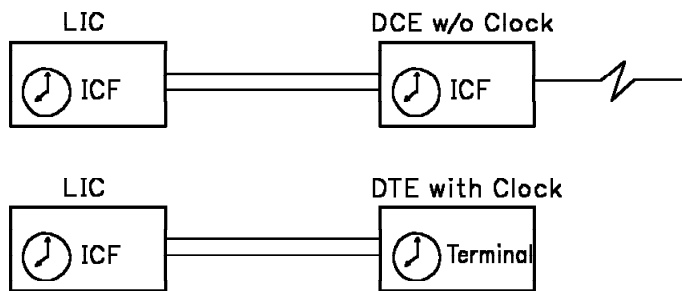

The internal clocking mode is set by the microcode at initialization time in the LIC card (ICF activated).

NCP parameters: clock=internal, speed=xxx.

The following data rates are available:

- Asynchronous lines (start-stop)
 - From 50 to 19 200 bps
 - 1200 bps transmit / 75 bps receive (for test purposes).
- Synchronous lines (BSC or SDLC)

- From 50 to 4800 bps.

3745 Mode

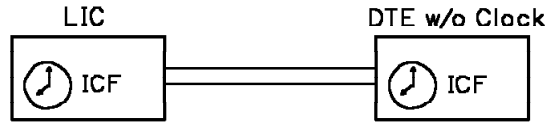

The 3745 clocking mode is set by the microcode at initialization time in the LIC card (ICF activated).

NCP parameters: =direct attach, speed=xxx.

The following data rates are available:

- Asynchronous lines (start-stop)
 - From 50 to 19 200 bps.
- Synchronous lines
 - Up to 245 760 bps for SDLC
 - Up to 55 845 bps for BSC

External Mode

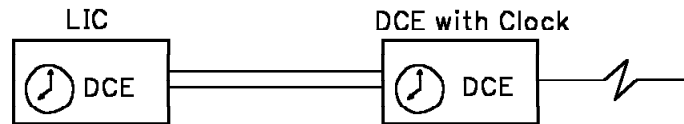

The external clocking mode does not activate the ICF since the DCE provides the transmit and receive clocks to both the LIC and itself.

LIC Wraps

Refer to:

- "Problem Determination Aid for LIC Types 1 to 4" on page 4-92 for more information on wraps
- *Advanced Operations Guide*, SA33-0097, to invoke these function from the MOSS console
- *Diagnostic Descriptions*, SY33-2059, for diagnostics using LIC wraps.

Two LIC wraps are available on the CCITT interface of the LICs:

- Loop 1 (line wrap)
- Loop 3 (loop back).

(LIC register X'2' bit 'Loop 1' or bit 'Loop 3').

Loop 1 on V.24

Loop 1 on the V.24 interface performs the following wraps:

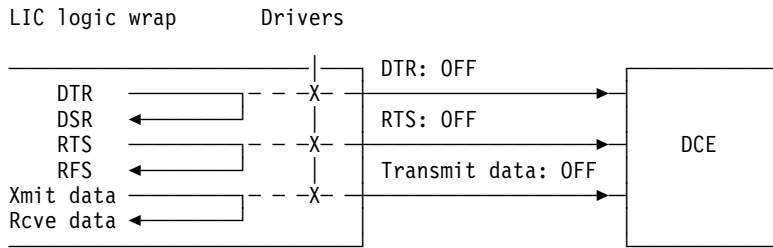

Loop 1 on V.25

For the V.25 autocal interface, transmit data line is replaced by digit present line inside LIC1 hardware and no transmit or receive clock is available.

Loop 1 on X.21

Loop 1 on the X.21 interface performs the following wraps:

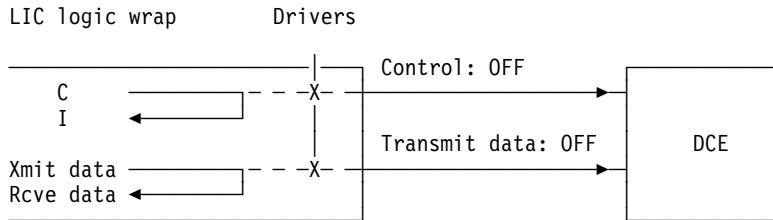

Loop 3 on V.24

Loop 3 on the V.24 interface performs the following wraps:

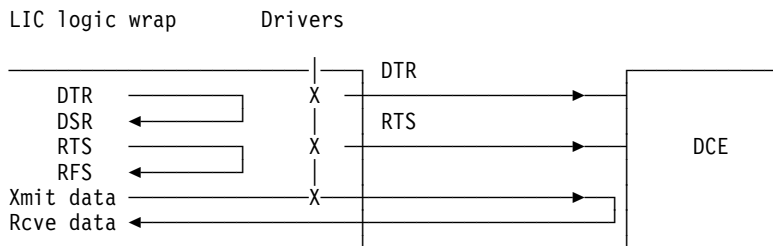

Only DTR and RTS are wrapped to DSR and RFS before the drivers.

Loop 3 on X.21

Loop 3 on the X.21 interface performs the following wrap:

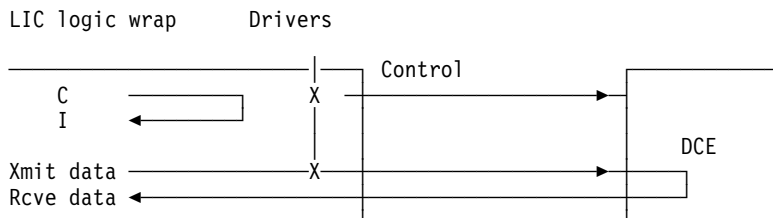

Hot Plugging of LICs

The bottom of the LIC card has three levels of indentation to provide the required power sequences.

When plugged power ON, the LIC logic gets into the reset state long enough to avoid transient disturbances on the interfaces.

LIC Types 5 and 6 DTE Function

The LIC types 5 and 6 provide DTE and integrated DCE functions. They connect SMUX cards to telecommunication lines.

- LICs type 5 connect to normal quality or M.1020/1025 4-wire telecommunication lines.
- LICs type 6 connect to DDS, local loops or unloaded baseband 4-wire lines in the US only.

Here follows information about the DTE part of LICs type 5 and LICs type 6 which is common to both LICs. Refer to the specific LICs type 5 or LICs type 6 section for DCE function.

Transmit/Receive Data Mechanism

LICs type 5 and LICs type 6 interconnection to SMUX cards is identical (the number and meaning of bits may however differ according to the type of line).

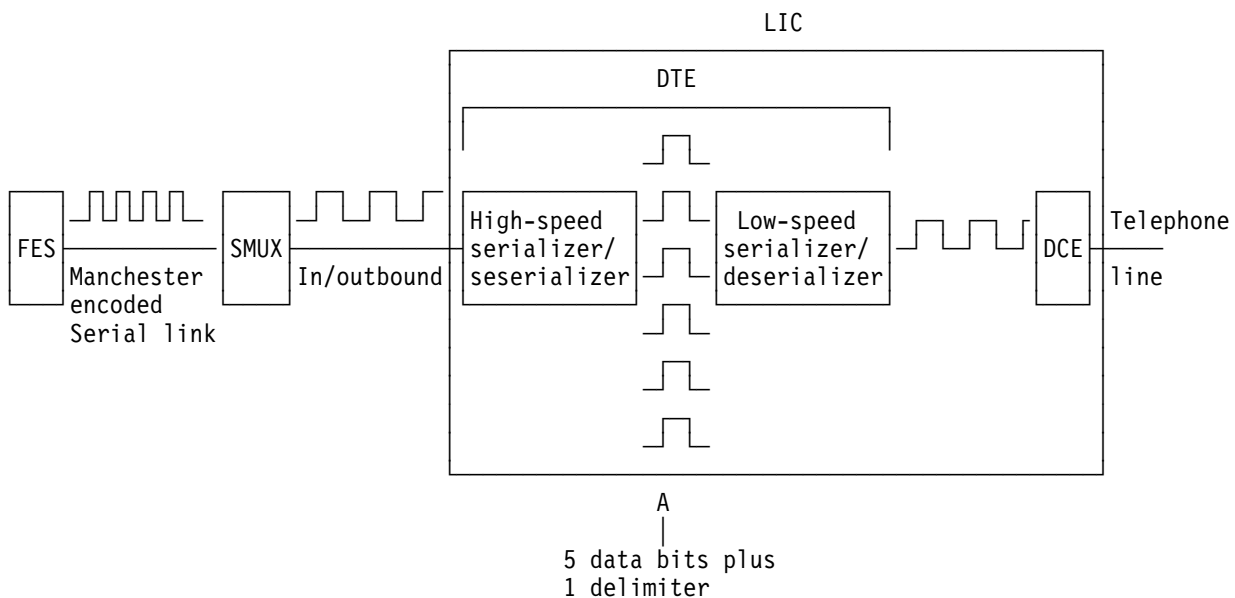

The data is passed from/to the FES to the telecommunication line via the MUX and LIC as shown above.

The LIC communicates with the FES to:

- Request new data to be transmitted (when in transmit mode)
- Signal 'transmit overrun': 'LIC line error register bit 3' (when in transmit mode)
- Signal 'transmit underrun': 'LIC line error register bit 3' (when in transmit mode)
- Signal 'overrun': 'LIC line error register bit 2' if more than 5 data bits are received between two serial link requests (when in receive mode).

LIC Reset

See "SMUX Reset" on page 4-42, and "LIC Reset" on page 4-44.

Line Enable/Disable

See “Line Enable/Disable” on page 4-44.

Selective Scanning

See “Selective Scanning” on page 4-45.

LIC Swap

See “LIC Swap” on page 4-46, keeping in mind that LICs type 5 have only four logical addresses per SMUX card.

LIC Address Register Contents

Write mode		Read mode	
Bits	Meaning	Bits	Meaning
0	LIC logical address bit 0	0	LIC wired address bit 0
1	LIC logical address bit 1	1	LIC wired address bit 1
2	LIC logical address bit 2	2	LIC wired address bit 2
3	Enable/disable logical add	3	Odd position
4	Not used	4	EC number
5	Not used	5	EC number

LIC Control Register

The LIC control register X'02' bit 1 and bit 3 (line enable E0 and E1) controls the swapping.

Bits	Meaning
0	Not used
1	Line enable E0
2	Not used
3	Line enable E1
4	Not used
5	Transmit bit echo

LIC Wraps

Refer to

- “Problem Determination Aid for LIC Types 1 to 4” on page 4-92 for more information on wraps
- *Advanced Operations Guide*, SA33-0097 to invoke these functions from the MOSS console.

Loop 3 on V.24

Loop 3 on the V.24 interface performs the following wraps:

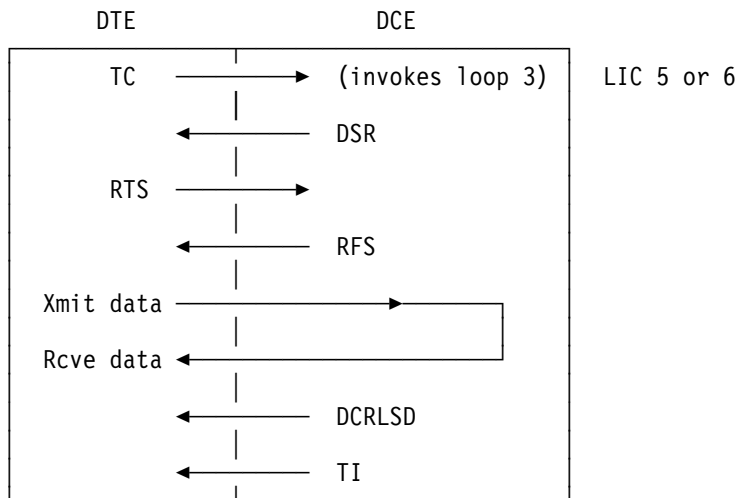

Loop 3 is performed between the transmitter output and the receiver input (before the line transformers) in the DCE part of LIC type 5 and LIC type 6.

A 700 Ω load is maintained on the line during loop 3. Loop 3 is started by 'test control' (TC) rise. The DCE answers back by rising 'test indicator' (TI), then starts data looping.

LICs Hot Plugging

LIC card bottom connector have three levels of indentation to provide the required power sequences.

When plugged power ON, the LIC logic gets into the reset state for a time long enough to avoid transient disturbances on the interfaces.

LIC Type 5 DCE Function

Maintenance Approach

Four basic methods are used to identify network/link problems or DCE failures:

1. Link problem determination aid (LPDA-2) hardware function implemented in each LIC type 5 DCE.

LPDA-2 is used in conjunction with the NetView program and console at host location. LPDA-2 commands and report messages are given in *LPDA Description*, SY33-2064.

2. MOSS wrap tests.
3. Diagnostics invoked from the MOSS console.
4. Manual tests from:
 - LIC type 5 panel or
 - 5869 portable keypad display (PKD).

For details, see “Problem Determination Aid for LIC Type 5 and LIC Type 6” on page 4-95, and appropriate 786X and 5822 documentation listed in the MIP bibliography.

Data Flow

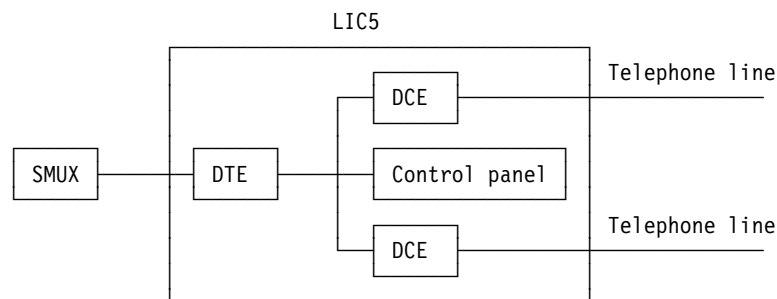

Logic Part

- DTE serializer/deserializer
- DCE microprocessor and signal processor
- DCE ROS, RAM, and NV PROM.

Analog Part

- DCE coder/decoder
- DCE transmit/receive filters
- DCE line transformers.

Speeds

Each LIC type 5 houses two DCEs which can operate at: 4800 bps (2400 bps backup), or 9600 bps (7200 bps backup), or 14 400 bps (12 000 bps backup) over non-switched 4-wire telephone lines.

In the event of severe degradation due to temporary line problems, the backup speed may be used.

In multipoint network, the backup inbound speed may be required for only one or several drops, while the other drops continue to operate at full speed.

Speed Setting

The speed is set at LIC installation from the PKD, and can be different for each DCE of a given LIC type 5.

The speed setting cannot be done either by NetView or by MOSS.

Configurations

LIC type 5 DCEs are compatible with IBM 586X and 786X DCEs. They operate in point-to-point or multipoint configurations as follows.

Point-to-Point - LIC Type 5 to LIC Type 5

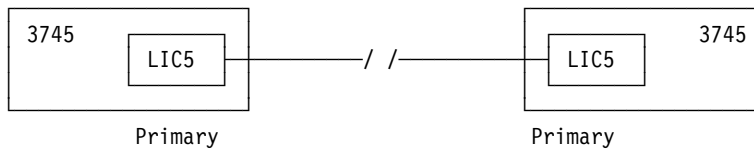

Point-to-Point - LIC Type 5 to 586X or 786X

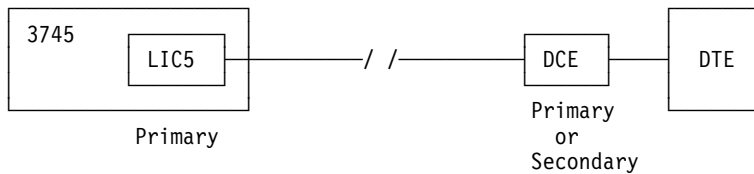

Point-to-Point - LIC Type 5 to Tailed 586X

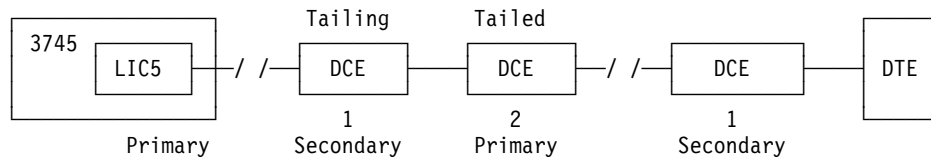

- 1: Transmit clock** = received
- 2: Transmit clock** = external
- Speed control** = DTE.

Multipoint - LIC Type 5 to LICs Type 5

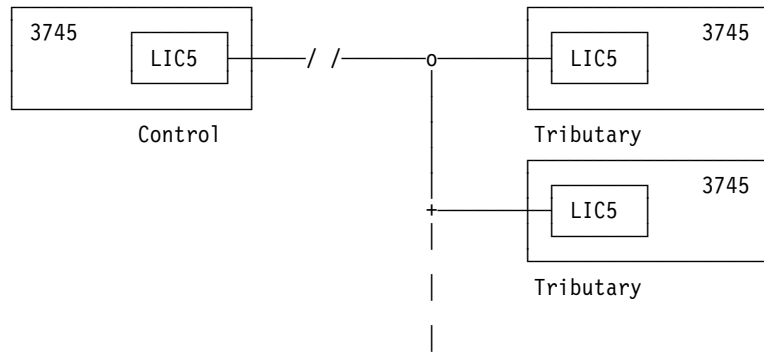

Multipoint - LIC Type 5 to 586Xs

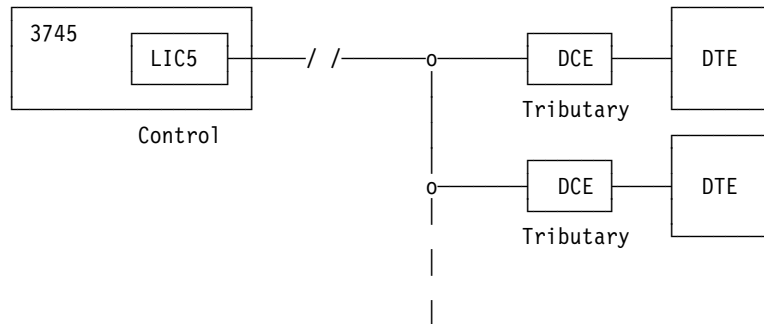

Multipoint - LIC Type 5 to One Tailed 586X

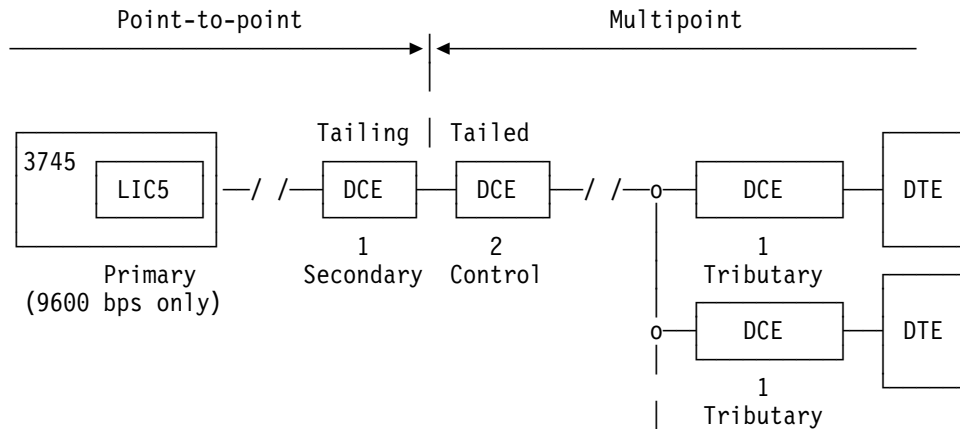

- 1: Transmit clock** = received
- 2: Transmit clock** = external
- Speed control** = DTE.

Multipoint - LIC Type 5 to 586Xs (Including Tailed)

This configuration does not support LPDA2.

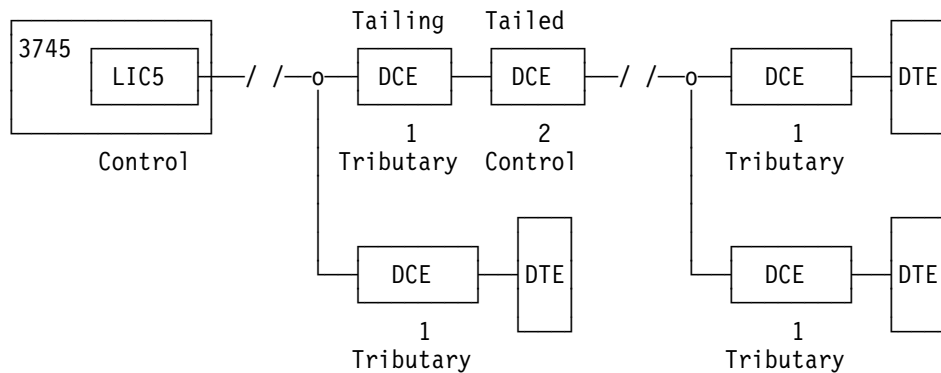

- 1: Transmit clock** = received
- 2: Transmit clock** = external
- Speed control** = DTE.

Configuration Options

Depending on the 'IBM native' or CCITT type of modulation, the different ways of setting the various CNM functions are as follows:

CNM functions	Modulation		Settable by		
	IBM native	CCITT	NetView	PKD	MOSS
Manual commands	Yes	Local	No	Yes	No
Local wrap (loop 3)	Yes	Yes	No	Yes	Yes
Remote wrap (loop 2)	Yes	Yes	No	Yes	No
Local self-test	Yes	Yes	Yes	Yes	Yes
LPDA-2	Yes	Local	Yes	No	No
Sense/operate contacts	Remote	No	Yes	Yes	No

Although LIC type 5 has no 'sense/operate' contact feature, it is possible to have these functions implemented in the remote 586X, and use them through a LIC type 5.

Data Encoding and Modulation

LICs type 5 use combined amplitude and bi-phase differential modulation encoding. Each couple (phase, amplitude) corresponds to a single bit pattern.

In addition, the data is scrambled/descrambled to avoid single frequencies over the telephone line when repetitive data patterns appear at the DCE interface.

Below are the:

- Modulation rate
- Carrier frequency
- Number of encoded bits per signaling period
- Modulation type.

For the A to E configurations shown in the following table:

	A	B	C	D	E	F	G
14 400 bps	*	*					
9600 bps			*	*	*		
4800 bps						*	*
Native	*		*	*		*	
CCITT V.27 bis							*
CCITT V.33		*					
CCITT V.29					*		
Point-to-point	*	*		*	*	*	*
Multipoint inbound			*	*		*	*
Multipoint outbound	*			*		*	*

A - Native Mode		
Speed	14 400 bps	12 000 bps
Modulation Rate	2400	2400
Carrier Frequency	1700 Hz	1700 Hz
Number of encoded bits per signaling periods	6	5
Modulation	QAM trellis coded	QAM trellis coded
RTS/RFS Delay	2 ms	2 ms

B - CCITT Mode		
Speed	14 400 bps	12 000 bps
Modulation Rate	2400	2400
Carrier Frequency	1800 Hz	1800 Hz
Number of encoded bits per signaling periods	6	5
Modulation	QAM V.33	QAM V.33
RTS/RFS Delay	2 ms	2 ms

C and D - Native Mode		
Speed	9600 bps	7200 bps
Modulation Rate	2400	2400
Carrier Frequency	1700 Hz	1700 Hz
Number of encoded bits per signaling periods	4	3
Modulation	QAM, or QAM with TCM	QAM, or QAM with TCM
RTS/RFS Delay	2 ms	2 ms

E - CCITT Mode			
Speed	9600 bps	7200 bps	4800 bps
Modulation Rate	2400	2400	2400
Carrier Frequency	1700 Hz	1700 Hz	1700 Hz
Number of encoded bits per signaling periods	4	3	2
Modulation	QAM V.29	QAM V.29	QAM V.29
RTS/RFS Delay	2 ms	2 ms	2 ms

F - Native Mode		
Speed	4800 bps	2400 bps
Modulation Rate	2400	2400
Carrier Frequency	1700 Hz	1700 Hz
Number of encoded bits per signaling periods	2	1
Modulation	4-phase differential encoding	4-phase differential encoding
RTS/RFS Delay	2 ms	2 ms

G - CCITT Mode		
Speed	4800 bps	2400 bps
Modulation Rate	1600	1200
Carrier Frequency	1800 Hz	1800 Hz
Number of encoded bits per signaling periods	3	2
Modulation	8-phase differential encoding	8-phase differential encoding
RTS/RFS Delay	2 ms	2 ms

DCE to Telephone Line Interface

LIC type 5 interfaces the telephone line through balanced impedances matching the networks (both input and output circuitries may be regarded as 2-port networks).

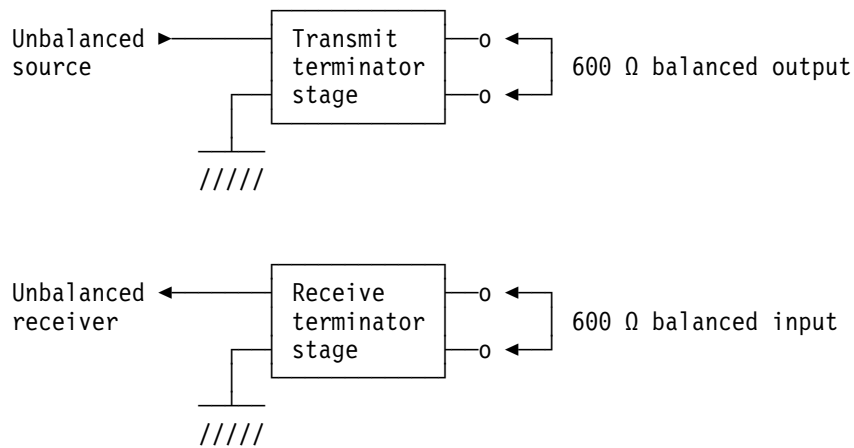

The circuits are not damaged:

- Under open circuit condition
- By a short circuit between the leads
- By a short circuit from either lead to ground.

The DC isolation between input and output leads with regard to ground is greater than 20 MΩ.

Surge Protection

1. **Primary protection:** a telephone line surge protection (carbon block or gas tube) should also be provided by the line connector before the DCE wall plug.
2. **Secondary protection:** three protection devices connected from tip to frame ground, from ring to frame ground, and tip to ring.

In the countries where it is authorized, this limits the maximum voltage to 80 V peak (line to ground) or 80 volts peak (line to line). In addition, the transformer saturation characteristics, and the Zener diode network across the line transformer secondary windings, limit the maximum peak voltage to 12 V (line to ground).

Transit Time

The transit time is the time that elapses between the input of a bit in the local transmitter and the output of this bit from the remote receiver, assuming a zero transmission delay over the telephone line.

Modulation type	Transit time (ms)					
	14 400	12 400	9600	7200	4800	2400
IBM Native	21.4	21.4	17.2	18.0		
CCITT V.33	21.4	21.4				
IBM Native			18.0	18.0		
CCITT V.29			16.8	16.8	16.8	
IBM Native					17.4	21.4
CCITT V.27 bis					12.2	15.6

RFS Delay

The RFS delay is 2 ms for LICs type 5 in any configuration. It must be added to the transit time to evaluate the turnaround time.

LIC Type 5 Panel

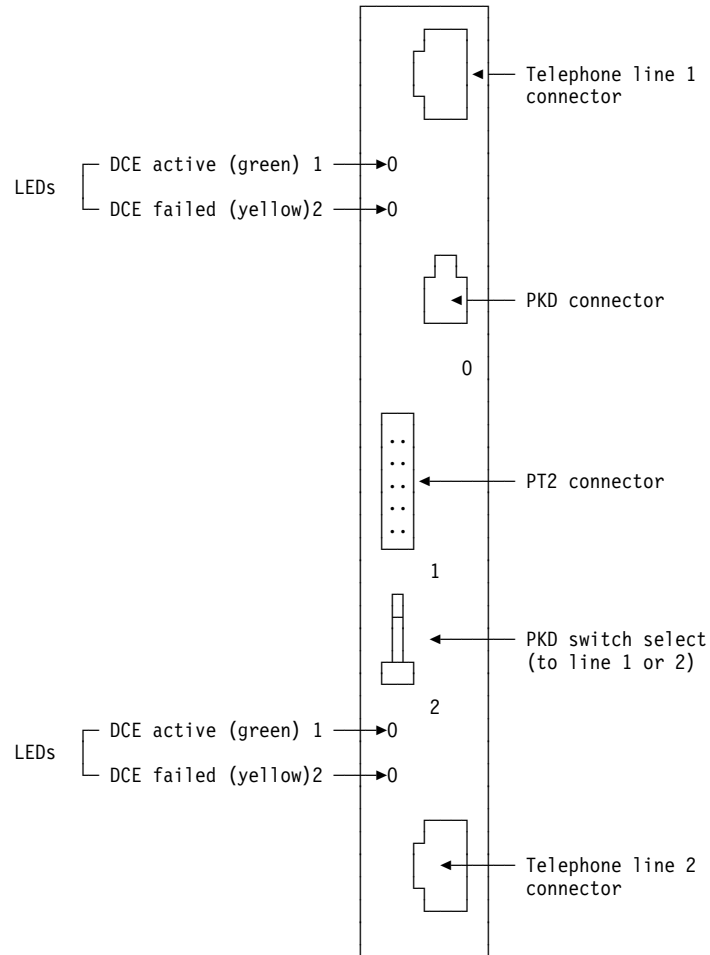

1 lit	DTR is ON (green LED)
2 lit	Severe local DCE error is detected (yellow LED)
1 and 2 flashing	LIC card plugged in a wrong place

Line Specifications

- 4-wire non-switched lines
- US and Canada: non-conditioned
- Other countries: CCITT M.1020 or M.1025 conditioning.

Line Spectrum

- V.27 bis
 - Centered on 1800 Hz
 - Spreads from 1000 to 2600 Hz.
- Native and V.29
 - Centered on 1700 Hz
 - Spreads from 450 to 3050 Hz, including a 12.5 % roll-off.

- V.33
 - Centered on 1800 Hz
 - Spreads from 600 to 3000 Hz.

3002 Channel (US) Characteristics

Attenuation distortion	(Overall loss relative to that at 1004 Hz): -2 to + 8 dB from 500 to 2500 Hz -3 to +12 dB from 300 to 3000 Hz
Delay distortion	Less than 1750 μ s from 800 to 2600 Hz
Insertion loss at 1004 Hz	16 dB
Non-linear distortion (H2)	25 dB minimum
Non-linear distortion (H3)	30 dB minimum
Phase jitter	No more than 10° peak-to-peak
Frequency shift	\pm 5 Hz
Signal to noise ratio	24 dB
Impulse noise	Threshold of -6 dB to signal level at an average rate of 15 impulses per 15 mn.

M.1020 Line Characteristics

Attenuation distortion	(Overall loss relative to that at 800 Hz): -2 to +6 dB from 300 to 500 Hz -1 to +3 dB from 500 to 2800 Hz -2 to +6 dB from 2800 to 3000 Hz
Delay distortion	(Group delay relative to the minimum group delay): Less than 500 μ s from 1000 to 2600 Hz Less than 1500 μ s from 600 to 2600 Hz Less than 3000 μ s from 500 to 2800 Hz
Insertion loss at 800 Hz	13 dB \pm 4
Harmonic distortion	25 dB minimum (below received level)
Phase jitter	No more than 15° peak-to-peak (normally 10°.)
Frequency shift	\pm 5 Hz
Signal to noise ratio	24 dB
Impulse noise	Threshold of -8 dB to signal level, at an average rate of 18 impulses per 15 mn.

M.1025 Line Characteristics

Attenuation distortion	(Overall loss relative to that at 800 Hz): -2 to +12 dB from 300 to 500 Hz -2 to + 8 dB from 500 to 2500 Hz -2 to +12 dB from 2500 to 3000 Hz
Delay distortion	(Group delay relative to the minimum group delay): Less than 300 μ s from 600 to 2800 Hz Less than 1500 μ s from 1000 to 2600 Hz
Frequency error	Less than \pm 5 Hz
Insertion loss at 800 Hz	13 dB \pm 4
Harmonic distortion	25 dB minimum (below received level)
Phase jitter	No more than 15° peak-to-peak (normally 10°)
Frequency shift	\pm 5 Hz
Signal to noise ratio	24 dB
Impulse noise	Threshold of -8 dB to signal level at an average rate of 18 impulses per 15 mn.

Specific Country Line Characteristics

In the following countries, the line characteristics are specified by the PTT:

- **France**

The French PTT offer a 4-wire normal quality line with the following specifications:

Attenuation distortion (Overall loss relative to that at 800 Hz):
-2.6 to +4.5 dB from 500 to 2000 Hz
-2.6 to +6.0 dB from 300 to 2600 Hz
-3 to +9 dB from 1700 to 2300 Hz
-3 to +12 dB from 2300 to 2800 Hz
Loss at 800 Hz: 6.4 dB, with a possible variation of less than 4.5 dB.

Delay distortion (Group delay relative to the minimum group delay):
Less than 1000 μ s from 1000 to 2400 Hz
Less than 1500 μ s from 800 to 2600 Hz
The DC loop resistance of a wholly metallic line is less than 4000 Ω .

- **Japan**

The NTT offer a normal quality line (3.4 kHz service). According to NTT-supplied information, these lines should have the following specifications:

Attenuation distortion (Overall loss relative to that at 800 Hz over carrier section):
-3.8 to +13.0 dB from 300 to 400 Hz
-3.8 to +5.8 dB from 400 to 600 Hz
-3.8 to +3.8 dB from 600 to 2400 Hz
-3.8 to +9.4 dB from 2400 to 3000 Hz
-3.8 to +17.4 dB from 3000 to 3400 Hz

Delay distortion (Group delay relative to the minimum group delay):
Less than 1750 μ s from 1000 to 3000 Hz

- **UK**

The Post Office provides a quality telephone line according to CCITT recommendation M.1025.

Options and Configurations

The options are entered from the PKD, using the 'CONF' command or via LPDA-2 commands. They are stored into a non-volatile RAM except for microcode and EC levels.

These options are:

- Read and set by the customer
- Read and set by the CE only
- Read-only.

They can be read and set:

- Through the PKD
- Through the LPDA-2 commands
- In the local LIC type 5 DCE
- In the remote DCE (LIC type 5 or IBM 586X DCE).

The table below shows the various ways of reading and setting these options.

Keying 'LOCAL CONFIGURATION' will cause the DCE to display and scroll field by field its own configuration; the operator may update each configuration field which appears on the display.

If the operator does not update the configuration, TI is **not** raised and data traffic can take place without interruption.

If the operator updates the configuration, (keying 'ERASE'), TI is raised, CD and RFS are dropped at local interface, and the **data traffic through the DCE is interrupted**.

Keying 'REMOTE CONFIGURATION' causes the DCE to display and scroll the configuration of the selected remote DCE.

During the operation, TI is raised, CD and RFS are dropped at the local and the remote interface, and the DATA traffic through the DCE is interrupted.

Options	Settable in the Local LIC Type 5		Settable in the Remote LIC Type 5 (if not CCITT)	
	PKD	LPDA-2	PKD	LPDA-2
DCE address	*		*	
Default speed	*	*	*	*
Point-to-point - Multipoint	*	*	*	*
Control - Tributary	*	*	*	*
Type: IBM native	*		*	
Long training sequence	*	*	*	*
Anti streaming	*	*	*	*
Transmit clock control	*	*	*	*
RFS delay	*	*	*	*
Line quality threshold	*	*	*	*
Receive level threshold	*	*	*	*
Hit count threshold		*		*
Nonswitching transmit level	⊠			
CCITT	⊠			
CD sensitivity	⊠			
LPDA-1 enable				
LPDA-2 enable	*		*	
2nd backup speed	*	*	*	*
Auto self-test	*	*	*	*
Switched transmit level				
Autoanswer				
Ring protection				
Autodisconnection				
Telephone numbers				
Serial number				
Base card EC level	Δ	Δ		
Machine EC level				
Microcode EC levels	Δ	Δ		
Customer information		*		*

* Read and set by customer

⊠ Set by CE only

Δ Read-only.

Note: As options and some other configuration items can be set either locally or remotely, contentions may occur. The last received configuration, either from the line or from the attached operator panel, overrides the previous one.

Some of the above options are self explanatory; the others are explained hereafter.

DCE address

- Control and primary LIC type 5s : always 01
- Tributary and secondary LIC type 5s : any value

Default speed The non-volatile RAM holds the default speed indication, defined at configuration time, which is used at each power ON.

Point-to-point/multipoint

LIC type 5 can be 'Primary', 'Control', 'Secondary', or 'Tributary'.

Transmit clock control

Two options are available:

Internal clock The transmit clock is provided internally by the LIC type 5.

Receive clock The local transmit clock is locked onto the receive clock (decoded from the received data).

Line quality threshold

From 0 to 15, displayed in hexadecimal (0 to F).

- LPDA-2 setting ranges from 0 to E
- Control panel setting ranges from 0 to F. F means 'no threshold'.

If the line quality parameter is above or equal to that threshold, the line quality indication 'LQ' in the background information blinks on the displayed value, and the buzzer gives an audible alarm.

At installation, the threshold value is 8 which corresponds to a 10^{-5} bit error rate.

Receive level threshold

This is to specify the threshold above which a warning indication will be reported during LPDA-2 modem and line status report.

The range is from 0 to -43 dBm.

Carrier detector sensitivity

Two sensitivities are provided:

Low CD sensitivity Received signal below 31 dBm is not detected

Normal CD sensitivity Received signal is detected down to 43 dBm.

LPDA-2 hit count threshold

From 0 to 64. This field cannot be accessed from the control panel.

LPDA-2 setting ranges from 0 to 63. (64 means: 'no threshold').

Transmit level See SMUX A/B section for authorized levels and settings.

CCITT Applied to point-to-point, makes the LIC type 5 compatible with CCITT V.27 bis, V.29 or V.33 recommendation for 4800, 9600 or 14 400 bps.

LPDA-2 enabled

Enabled Default option. The DCE intercepts and executes LPDA-2 commands.

Disabled the DCE ignores LPDA-2 commands.

Since LPDA-2 commands flow into the DCE as other pieces of data, the disable option may be selected if there is a chance that the LPDA-2 header may be erroneously detected in the data bit stream. The LPDA-2 header is guaranteed unique for the following data transmission protocols:

- SDLC NRZI
- BSC USACII or EBCDIC
- ALC.

First/second backup speed

Only used with CCITT V.29 option, to specify whether the 7200 or 4800 bps backup speed is used.

Card EC level One digit, from 0 to 3, wired on the LIC5 card, that specifies the level of the electronic components.

Microcode EC level

The EC level of the ROS and UVROMs can be read on the PKD from the ROS themselves. They cannot be updated.

Host Support

Host support for LIC type 5 is NetView from R3, using LPDA-2 functions. See *LPDA Description*, SY33-2064 for LPDA-2 protocols, formats, and commands.

Three sets of commands are available for:

- Problem determination
- DCE configuration
- Testing from the TSS.

Problem Determination Commands

Supported commands are:

- DCE status and test
- Line status
- Transmit/receive test
- Line analysis.

DCE Configuration Commands

The following 'operational commands' are supported:

- Read local configuration
- Write local configuration
- Set local transmit speed
- Read remote configuration
- Write remote configuration
- Set remote transmit speed

- Remote contact sense/operate.

Note: The following commands are **not supported**:

- Call-out
- Disconnect
- Local contact sense/operate in local LIC type 5
- Read local coupler
- Read remote coupler
- Write local coupler
- Write remote coupler.

TSS Commands

Two commands can be initiated from the TSS (FESA) to test the LIC type 5:

- CCITT loop 3 (with or without line wrap block)
- Self-test.

CCITT loop 3

This test is initiated by the 3745 TSS (FESA) on the DTE interface. The FESA has to detect RFS going ON before sending the data to be looped. For security purpose, the FESA can set up a timer (2100 ms maximum) to guard against no answer from a failing DCE.

The TSS/FESA follows the following sequence:

1. Start loop
 - Put RTS OFF
 - Detect RFS OFF in less than 50 ms
 - Set TC ON
 - Detect TI ON in less than 700 ms
 - Set RTS ON
 - Detect RFS ON in less than 200 ms
 - Send data to be looped on TD.
2. End loop
 - Stop data transmission
 - Put RTS OFF
 - Detect RFS OFF in less than 50 ms
 - Put TC OFF
 - Detect TI OFF in less than 100 ms.

Self-test The self-test from OFFline diagnostics pre-empts any other DCE functions.

It can be run only when the DCE is not connected to the network, and it doesn't need any line wrap plug.

The 'MODEM FAILED' bit is set to 1 in case of error. The 'MODEM BUSY' bit is raised solely as an answer to the self-test request from the 3745.

The test sequence is as follows:

1. Read interface
 - 'Modem failed' bit ON = error
 - 'Modem busy' bit staying ON for more than 4 s = error.
2. Set 'Self-Test Request' ON
 - 'Modem busy' should come ON in less than 200 ms.
3. Put 'Self-Test Request' OFF (to avoid continuous self-test)
 - 'Modem busy' should come OFF in less than 4 s.

'Modem failed' OFF = self-test successful.

Manual Tests

The following manual tests are all initiated from the PKD:

	Data disruptive
• Local loop back	yes ¹
• Remote loop back	yes ¹
• Local self-test	yes ¹
• Local status	no
• Remote self-test	yes
• Remote status	yes
• Digital test (xmit/receive test)	yes ¹
• Analog test (line analysis)	yes
• LIC line analysis procedures (LLAP)	yes

¹ Run continuously until keying 'EXIT'.

Descriptions of the above manual tests are given later in this chapter, under 'Problem Determination Aid' for LIC type 5/LIC type 6.

Alarm Tone Detection

A failure tone is sent when a hard internal failure is detected. However, LIC type 5 DCEs detect both:

- Remote power OFF tones
- Remote failure tones.

Alarm tones are not detected if the DCE is executing a self-test.

If a failure tone and a power OFF tone are detected while executing a local status, only one of them is displayed.

Tone Characteristics

Frequency 325 Hz \pm 10 Hz

Level As written in NVRAM (default value provided by the switches on the SMUX card)

Power OFF tone duration

- 100 ms \pm 20 ms if power OFF lasts more than 100 ms
- Equals the power OFF duration if power OFF lasts less than 100 ms.

Failure tone duration

300 ms (repeated every 90 s until the DCE is powered OFF or the internal error disappears).

Tone Reception

The detection is controlled by the microprocessor, which monitors the tone duration in order to differentiate the power OFF tone from the failure tone.

DCE Configuration

DCE (LIC type 5 or 586X) configuration (local or remote) is achieved by keying a set of commands from the IBM 5869 PKD connected to the relevant LIC type 5. See the *MIP*, SY33-2070 for detailed command procedures.

Portable Keypad Display (PKD)

The IBM 5869 PKD consists of a keyboard of 20 keys associated with a 16-character alphanumeric display, and audible alarm.

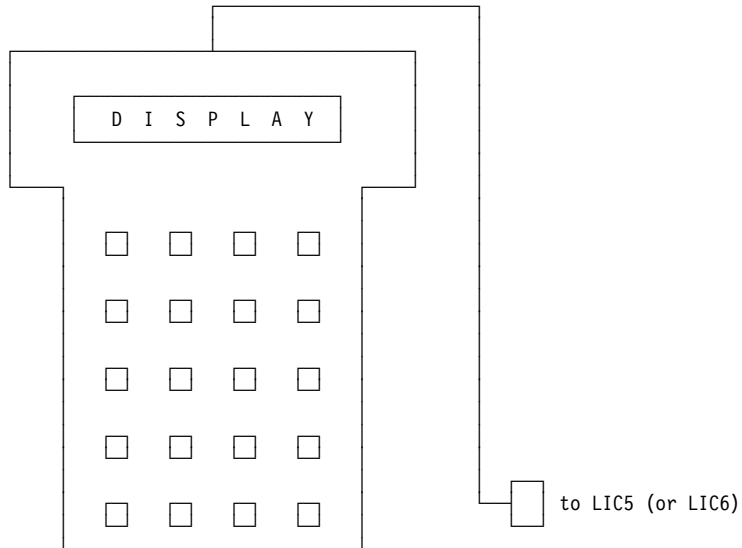

KEYPAD

	TEST	STATUS	SPEED	CONFIG
LOC	0	1	2	3
	TEST	STATUS	FULL	CONFIG
REM	4	5	6	7
	ANALOG	DIGITAL	BCKUP	CMD
	8	9	A	B
	PD			LOC. LOOP
	C	D	E	F
	GO	ERASE	EXIT	STOP

the following are the available main display operations. For procedures, display analysis, and actions, refer to:

- *3745 Problem Determination Guide, SA33-0096*
- *3745 Connection and Integration Guide, SA33-0141.*

Lamp Test

The 'GO' key displays all positions during 5 s on the screen to test the LEDs.

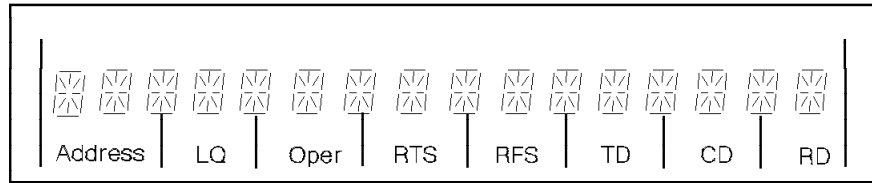

A specific key display can also be tested (by keeping that key pressed longer than 5 s).

Background Information

This is the default information that appears on the screen in normal mode. You find, from left to right:

- 3745 line physical (or logical in case of LIC swap) address: 2 characters
- Line quality irrelevant = x: x from 0 to F (0 is the best)
- Operate OFF = x: L = Non-switched, W = Local wrap via TC
- RTS OFF = 0 ON = 1
- RFS OFF = 0 ON = 1
- CD OFF = 0 ON = 1
- TD blinks on TD activity, indicates also speed of transmission: F = full, B = backup
- RD blinks on RD activity, indicates also speed of reception: F = full, B = backup.

Notes:

1. 'WRAP' is displayed instead of line address and line quality if a manual loop back test is running.

Transitions between 0 and 1 on the screen indicate that activity is taking place on the lead (except for RD and TD). If there is no activity the actual status is displayed.

- 2.

When CD = 0, RD indicates the speed of last data reception.

When RFS= 0, TD indicates the speed of last data transmission.

DCE Information

When the background information is displayed, keeping the **ERASE** key pressed will give you a display of the form:

aaaa bbb cc

where:

aaaa 4800 bps or 9600 bps or 14 400 bps or V.27 or V.29 or V.33

bbb Transmit clock option

- INT for internal (from local)
- RCV for received (from remote).

cc Network configuration

- PP for point-to-point primary
- PS for point-to-point secondary
- MC for multipoint control

- MT for multipoint tributary
- MT for CCITT V.29 or V.33.

This operation is not data disruptive. Releasing the **ERASE** key returns to background display.

LIC 5 Physical Address

When the background information is displayed, press the EXIT key for more than 0.5s. The LIC physical position on the board is then displayed.

POR - Bring-Up Information

At power ON reset time all the segments on the screen are lit (*), then 'COPY-RIGHT IBM 88' appears on the screen.

Normally, after the initial self-test is completed, the screen displays the background information. In the normal case, the DCE goes to 'operate'. If a severe problem occurs, the '*' remain on the screen.

If the initial self-test detects a severe error, the message:

LIC 5 FAILED

appears on the screen during 2 s and the DCE loops on bring-up.

Keying Procedures

Each function is performed in three steps:

1. Selection
2. Execution
3. Report.

Command Rejection

In some cases commands are rejected:

No response The remote did not answer, disruption of data transmission has already taken place.

Bad response The remote gave an invalid answer (wrong FCS), disruption of data has already taken place.

Busy TC ON If the lead TC is ON, all operator commands are rejected with the following message:

BUSY TC ON

The buzzer sounds one beep, and the message stays on the screen until the operator presses EXIT. There is no disruption of data.

Not executed The command can also be rejected with the 'NOT EXECUTED' message. Either it was a remote command and the DCE is in CCITT mode or the DCE is continuously busy with host commands (this may be an abnormal condition). If the message is caused by CCITT mode there is no disruption of data.

A remote speed change is not executed if the clock option of the remote DCE is not set to internal clock.

The buzzer sends the audible attention at the beginning of the report.

In report step, pressing a function key causes the return to selection step. This is a means to chain several commands without being pre-empted by commands coming from the host or the line (see contentions).

Self-Tests

The following self-tests are available:

- Local self-test (key 0)
- Remote self-test (key 4).

Status

The following status can be examined:

Local status Key 1. Not disruptive but forbidding LPDA-2 commands, informs on:

- Logged warnings
- Line quality end received level in dBm
- Hit count since the last 15 mn
- DTE interface local status and transitions

Remote status Key 5. Disruptive

- Logged warnings
- Line quality end received level in dBm
- Hit count since the last 15 mn
- DTE interface local status and transitions

Analog Test

This test (key 8) provides line analysis. It involves both local and remote DCEs and lasts 6 s on each side.

Digital Test

This test (key 9) is a transmit/receive test. It involves both the local and remote DCEs. Blocks of data are sent from the local to the remote DTE which wraps them back to the local one.

Block errors are counted on both sides and displayed on both screens. See page 4-98.

Local Loop

This command (key F) prepares the DCE for a loop 3 test. See page 4-56.

Speed Change

This option allows to change the speed locally and/or remotely from nominal to backup, and conversely. The speed cannot be changed if the remote DCE:

- Has the DSRS option
- Already runs at requested speed.

Configuration

The PKD being connected to a given DCE, the local DCE or the remote DCE configuration settings may be:

- Scrolled and displayed
- Updated.

Some fields are modifiable by the CE only, some others fields are 'read only' (for example, model).

If vital fields have been modified, returning to background causes a self-test to take place.

The table on page 4-68 shows the various configuration fields for local LICs type 5.

Contact Sense/Operate

These facilities are not available on LIC type 5, but on remote 586Xs only. They are:

- Open the 'contact operate' relay
- Close the 'contact operate' relay
- Get the status of the 'contact operate' and 'contact sense'.

Commands

The following commands can be executed in CE mode only:

- Send a 1004 Hz tone on the telephone line
- Load the default configuration (transmit level not changed)
- Update the configuration (all fields may be updated)
- Address a specific DCE via its serial number
- Long timer (10 mn) for LLAP
- Contact sense/operate (remote only).

All the above commands are reset at:

- Power OFF
- DCE re-initialization.

Buzzer Control

Each time a valid key is pressed there is a short bip. The absence of bip means that the key is either irrelevant to the current protocol or has not been taken in account by the keypad hardware.

Contentions

A request to execute an LPDA-2 command can come from:

- The local host
- The remote via the telephone line
- The panel.

Contentions are solved on a 'first request/first to be served' basis.

From the moment you release the GO key, until the end of the test, the DCE does not answer commands either from the line or from the DTE.

While executing a non-disruptive command the DCE does not answer LPDA requests from the host or from the line.

Re-synchronization is inhibited for remote commands.

Unsolicited Messages

These messages appear on the screen, without any operator intervention. If a PKD operator session is in progress the unsolicited messages are delayed. They can appear only when the screen displays background information. For complete information, refer to the *Configuration and Integration Guide*.

CMD FROM LINE (2 s)

CMD FROM DTE (2 s)

REM MODEM FAILED

Stays on screen until the operator presses EXIT. This message is not displayed if the PKD was not present when the condition occurred.

REM PWR LOSS In point-to-point, this message remains until CD goes ON or the operator presses EXIT. It appears as soon as the PKD is present if CD is still 0.

CONFIG FROM LINE

When the DCE is being configured from the line or from the host.

CONFIG FROM HOST

Disappears at end of configuration, or if a power loss or failure tone is detected. If end of configuration has not been received the message stays on the screen during 5 mn. This message appears as soon as the PKD is present if the condition still holds.

CONFIG MISMATCH

Configuration error.

KEY n STUCK

When the indicated key appears to be pressed during more than 5 s. The message stays 10 s then the control panel is reinitialized. This indicates a mechanical or electrical problem.

aa LIC5 FAILED

At power ON, the initial self-test failed. If the operator presses GO, the DCE attempts to start.

TEST FROM HOST

A test from the 3745 has been initiated.

WRONG SLOT

The cassette has been plugged in a wrong position.

TEST FAILED

A host self-test has failed.

SELF TEST FAILED

A self-test failed after a configuration change.

TEST OK

A self-test requested by the host was successful.

SELF TEST OK

A self-test was successful after a configuration change.

TEST OK NOWRP

A manual self-test without tel wrap plug was successful.

TEST OK WRAP

A manual self-test with tel wrap plug was successful.

PT2/3

A 10-pin connector is available on the LIC type 5 panel to connect a PT2/3 used to investigate and record control and data signals.

LIC Type 6 DSU/CSU Function

DSU/CSU stands for: 'Data service unit/channel service unit', which is, in the LIC type 6, the equivalent of the DCE function of a LIC type 5.

Connection to US DDS

The DSU/CSU allows DTE-to-DTE communication through the digital data service (DDS) in the US.

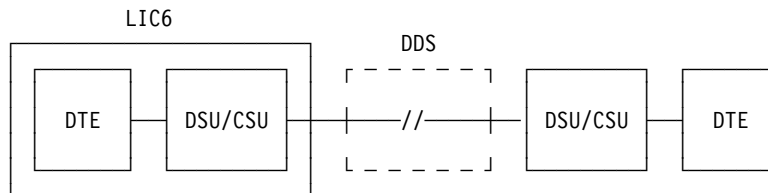

Limited Distance Connection

The DSU/CSU also allows DTE-to-DTE communication through private limited distance lines. The data is encoded and decoded as for DDS (protocols, rules, and so on).

Note: The LIC type 6 offers no local area data channel (LADC) attachment facility.

Maintenance Approach

Same as LIC type 5; see page 4-57.

Data Flow

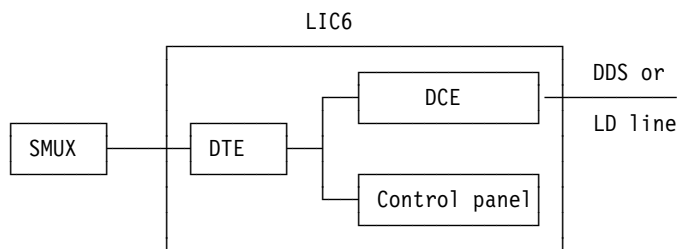

Logic part

- DTE serializer/deserializer
- DCE microprocessor and signal converter
- DCE ROS, RAM, and EEPROM.

Analog part

- DCE coder/decoder
- DCE transmit/receive filters
- DCE line transformers.

Speeds

Each LIC type 6 houses one DCE which can operate at the following speeds, depending on the network it is connected to.

US digital data service network

- 56 000 bps
- 19 200 bps
- 9600 bps

Non-switched 4-wire limited distance lines

- 56 000 bps
- 19 200 bps
- 9600 bps.

Speed Setting

The speed is set at installation time by a microswitch on the LIC type 6 card.

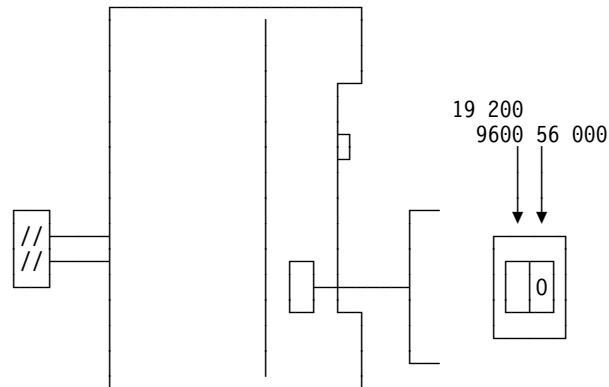

- In V.35-like mode (56 000 bps), only one speed is available.
- In V.24-like mode (19 200 and 9600 bps), two speeds are available and must also be set at installation time from the PKD.

The speed setting cannot be changed either by NetView or by the MOSS.

Configurations

LIC type 6 DSU/CSUs are compatible with IBM 5822-10 DSU/CSUs. They operate in:

- Point-to-point and multipoint when connected to DDS
- Point-to-point only when connected to a limited distance line.

Configuration Options

The following table shows the different ways of setting the CNM functions.

CNM Functions	Settable by		
	NetView	PKD	MOSS
Manual Command	No	Yes	No
Local wrap (loop 3)	No	Yes	Yes
Local self-test	Yes	Yes	Yes
LPDA-2	No	No	No

Data Format

Synchronous, binary serial.

Modulation Technique

Bipolar, return-to-zero.

DSU/CSU to Line Interface

The LIC type 6 interfaces the DDS/LDM through balanced impedances matching the networks (both input and output circuitries may be regarded as 2-port networks).

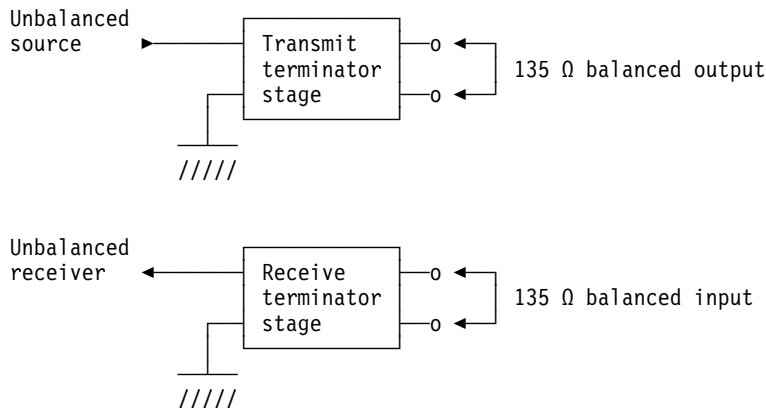

The circuits are not damaged under the following conditions:

- Open circuit
- Short circuit between the leads
- Short circuit from either lead to ground.

The DC isolation between input and output leads with regard to ground is greater than 20 MΩ.

Surge Protection

Primary protection

A line surge protection (carbon block or gas tube) should also be provided by the line connector before the DCE wall plug.

Secondary protection

One protection device connected from tip to ring and two capacitors, from tip to frame ground, and from ring to frame ground.

This limits the maximum voltage to 80 V peak (line to line).

Transit Time

The transit time is the time that elapses between the input of a bit in the local transmitter and the output of this bit from the remote receiver, assuming a zero transmission delay over the telephone line.

Transmitter and receiver refer to the V.24 interface.

	Transmission Speed (bps)		
	56 000	19 200	9600
Transit time (ms)	35	33	33

RFS Delay

The RFS delay is 7 to 20 bit-time for LIC type 6 in any configuration. It must be added to the transit time to evaluate the turnaround time.

9600 bps	2.5 ms
19 200 bps	1.5 ms
56 000 bps	0.5 ms

LIC Type 6 Panel

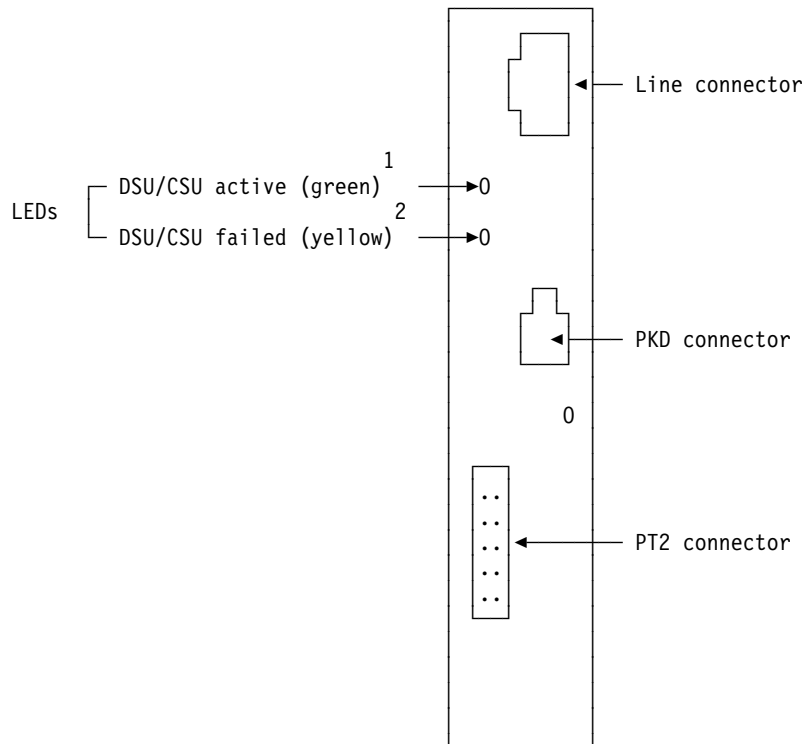

- 1 lit** DTR is ON (green LED)
- 2 lit** Severe local DSU/CSU error is detected (yellow LED)
- 1 and 2 flashing** LIC card plugged in a wrong place.

Line Specifications

DDS network Refer to DDS documentation

Limited distance connection

The line specification depends on the length and the gauge of the wires.

Lengths and Gauges

The next table gives the maximum lengths in km (and miles) for the most common gauges used.

Table 4-1. Maximum line length, according to wire diameter and transmission speed

Transmission Speed	Wire Diameter in mm/(Gauge)			
	0.4 (26)	0.5 (24)	0.6 (22)	0.8 (20)
56 000 bps	4.2 km (2.6 miles)	6.0 km (3.7 miles)	8.1 km (5.0 miles)	13.7 km (8.5 miles)
19 200 bps	5.8 km (3.6 miles)	7.9 km (4.9 miles)	10.2 km (6.3 miles)	15.7 km (9.7 miles)
9600 bps	7.3 km (4.5 miles)	9.8 km (6.0 miles)	12.6 km (7.8 miles)	18.7 km (11.6 miles)

Note: The most commonly used lines are 0.4 and 0.6 mm.

The distances given in the previous table (in kilometers and miles) are calculated for 34 dB of attenuation at the Nyquist frequency and associated with the following line parameters:

Line ic capacitor	50 nF / km
Line ic inductance	650 μ Henry / km
Line ic resistor	44/(DxD) in $\mu\Omega$ / km with D = line diameter in mm
Load impedance	135 $\mu\Omega$ (resistive).

Using an IBM cabling system type 1 (cable PN 4716748) or type 6 (cable PN 4716743) the expected distances will be:

- 4 km up to 19 200 bps
- 3 km at 56 000 bps.

On loops which meet the noise requirements defined in the *Bell PUB 62310* the bit error rate will not exceed 4/100 000.

At data rate over 19 200 bps, lines with a diameter greater than 0.6 mm will increase the group delay distortion.

Options and Configurations

The LIC type 6 is **not** configurable via LPDA-2 commands.

The speed option (V.35/V.24) is set from a switch on each LIC type 6 card but the speed option (19 200/9600) is set from the PKD. See "Speed Setting" on page 4-81.

The options are set in a non-volatile PROM, except for microcode and machine EC level.

The next table shows the options available to both customer and CE on local LIC type 6.

Options	Local LIC Type 6
Point-to-point - Multipoint	Yes
DSU/CSU - Limited distance	Yes
Timing source	Yes
Network services ¹	Yes
Byte 1 (speed V.35/V.24)	Switch
Speed 19 200/9600	Yes
DCE address	Read only
Anti streaming	No
TC enabled	No
Buffer enable	Yes
Serial number	No
Machine EC level	No
Microcode level	Yes

¹ If the option 'Network Services' is selected on the local LIC type 6, the option 'Network Services' or 'LPDA-2 Enable' must be selected on the remote DSU/CSU.

Point-to-point/multipoint

LIC type 6 can be 'Primary', 'Control', 'Secondary', or 'Tributary'.

DSU-CSU/LD Defines attachment to DDS network or limited-distance connection.

Timing source The receive clock provided by the LIC type 6 to the host is always recovered from the received signal.

The transmit clock can be provided by the LIC type 6 to the host in two different modes:

- Internal clock generation within the LIC type 6: this mode gives better performances in LDM connections
- Network clock used to generate transmit clock (synchronous mode).

Network services

- If selected (default option) the LIC type 6 intercepts and executes LPDA-2 commands
- If disabled, the LIC type 6 ignores LPDA-2 commands
- Since LPDA-2 commands flow into the LIC type 6 as other pieces of data, the disable option may be selected if there is a chance that the LPDA-2 header may be erroneously detected in the data bit stream. The LPDA-2 header is guaranteed unique for the following data transmission protocols:
 - SDLC NRZI
 - BSC USACII or EBCDIC.
 - ALC.

DCE address

- Control and primary LIC type 5 : always 01
- Tributary and secondary LIC type 5 : any value

Speed control See 'Speed Setting' on page 4-81.

Host Support

Host support for LIC type 6 is NetView, using LPDA-2 functions. See *LPDA Description manual*, form SY33-2064 for LPDA-2 protocols, commands, and formats.

Two sets of commands are available for:

- Problem determination
- Testing from the TSS.

Problem Determination Commands

Supported commands are:

- DSU/CSU status
- Line status
- Transmit/receive test.

TSS Commands

Two commands can be initiated by the 3745 TSS (FESA) to test the LIC type 6:

- CCITT loop 3 (with or without line wrap block)
- Self-test.

CCITT loop 3 This test is initiated by the 3745 TSS (FESA) on the DTE interface. It is the same as for LIC type 5. See page 4-71.

Self-test This test is the same as for LIC type 5. See page 4-71.

DDS Loop

This test is initiated by the DDS link via a bipolar code violation or a DC line current polarity reversal, as defined in the preliminary *ATT PUB 62310* dated September 1983. It consists in a wrap at the DTE interface:

1. Detect bipolar code violation or current polarity reversal
2. Raise TI
3. Set 'modem busy' bit ON in DTE registers
4. Drop CD and RFS, DSR kept ON
5. Force data to 'mark' at the host side, while looping back data from DDS
6. Detect end of bipolar code violation and current polarity reversal
7. Drop TI and reset the 'modem busy' bit.

The test lasts as long as a code violation or polarity reversal is detected. It runs only if the LIC type 6 is in operate mode.

Alarm Tone Detection

A failure signal is sent when a hard internal failure is detected, provided that 'network services' are enabled. This signal contains in a long sequence of bipolar zeroes.

However, LICs type 6 detect both:

- Remote power OFF tones
- Remote failure tones.

Tone Characteristics

Speed data speed

Duration

Power OFF 126 zeroes

Failure 252 zeroes

End-to-end passthrough delay

varies from 32 to 64-bit times depending on the configuration.

Tone Reception

The LIC type 6 receiving the alarm signal detects the alarm pattern and interprets the information as a remote failure or power OFF.

This information is kept in storage and is reported to the NCP on request.

DSU/CSU Configuration

DSU/CSU (LIC type 6 or 5822-10) configuration is achieved locally only by keying a set of commands from the IBM 5869 PKD connected to the relevant LIC type 6.

Portable Keypad Display (PKD)

See PKD, page 4-74.

Lamp Test

See page 4-75.

Background Information

This is the default information that appears on the screen in normal mode. You find, from left to right:

- 3745 line physical address (logical in case of LIC swap): 2 characters
- Line quality irrelevant = x : x from 0 to F (0 is the best)
- Operate OFF = X : L = leased, W = local wrap via TC, D = DDS loop test
- RTS OFF = 0 ON = 1
- RFS OFF = 0 ON = 1
- CD OFF = 0 ON = 1
- RD blinks on TD activity, indicates also speed of transmission: F = full, B = backup
- TD blinks on RD activity, also indicates speed of reception: F = high, B = low.

Notes:

1. 'WRAP' is displayed instead of DSU/CSU address and line quality if a local manual loop back test is running.
2. Transitions between 0 and 1 on the screen indicate that activity is taking place on the lead.

If there is no activity the actual status is displayed.

DSU/CSU Information

When the background information is displayed, the operator can request the local DSU/CSU main information, by keeping the 'ERASE' key pressed. The display show the information in the form:

```
ttt ccc nn mmm
```

where:

- ttt** Type of functioning
- 56 000 bps
 - 19 200 or 9600 bps
- ccc** Transmit clock option
- INT for internal (from local)
 - NC for network clocking (from remote)
- nn** Network configuration
- PP** Point-to-point primary
- PS** Point-to-point secondary
- MC** Multipoint control
- MT** Multipoint tributary

mmm Connection mode

- DDS for connections to DDS network
- LDM for limited distance connections

The DSU/CSU information is displayed as long as the operator keeps pressing the ERASE key. Release the ERASE key to return to background display.

This operation is not data disruptive.

POR - Bring Up Information

Same as for LIC type 5; see page 4-76.

Keying Procedures

Same as for LIC type 5; see page 4-76.

Command Rejection

Same as for LIC type 5; see page 4-76.

Notes:

1. 'DTE ONLY' command rejection not available.
2. 'DDS LOOP ACTIVE' brings a command rejection.

Digital Test

See page 4-99.

Local Loop Back

This command prepares the DCE for a loop 3 test. See page 4-96.

Speed Change

Only for 19 200/9600 bps. See "Speed Settings", page 4-81.

Configuration

The PKD being connected to a given LIC type 6, the **local** DSU/CSU configuration settings may be:

- Scrolled and displayed
- Updated.

Some fields are 'read only' (for example, machine level).

If vital fields have been modified, returning to background causes a self-test to take place.

The table on page 4-85 shows the various configuration fields for local LIC type 6:

Buzzer Control

Same as for LIC type 5; see page 4-78.

Contentions

Same as for LIC type 5; see page 4-78.

Note: If a function is selected while a loop (loop 3 or DDS loop) is being executed, a message (BUSY TC ON or DDS LOOP ACTIVE) appears on the screen.

If TC raises after selection but before execution BUSY TC ON is displayed.

Unsolicited Messages

These messages appear on the screen, without any operator intervention. If a PKD operator session is in progress the unsolicited messages are delayed. They can appear only when the screen displays background information. For complete information, refer to the *Configuration and Integration Guide*.

LDM LINE DOWN or DDS LINE DOWN

Lack of receiver timing or error on received block.

DDS OOS or DDS OOF

DDS out frame or DDS out of service indication.

CMD FROM LINE (2 s)

CMD FROM DTE (2 s)

REM DSU/CSU FAILED

Stays on the screen until the operator presses EXIT. This message is not displayed if the PKD was not present when the condition occurred.

REM PWR LOSS

In point-to-point, this message remains until CD goes ON or the operator presses EXIT. It appears as soon as the PKD is present if CD is still 0.

KEY n STUCK

When the indicated key appears to be pressed during more than 5 s. The message stays 10 s then the operator panel is reinitialized. This indicates a mechanical or electrical problem.

aa LIC6 FAILED

At power ON, the initial self-test failed.

DEFAULT CONFIG

Operator intervention is required to reconfigure the DSU/CSU.

INV PATTERN RCV

Invalid pattern received (ex: a DDS pattern in LDM mode).

TEST FROM HOST

A test has been initiated from the 3745.

WRONG SLOT

The cassette has been plugged in a wrong position.

MAND DDS LOOP

A mandatory DDS loop has been initiated from the DDS (reversal polarity loop).

OPT DDS LOOP

An optional DDS loop has been initiated from the DDS (bipolar code violation loop).

TEST FAILED

A manual self-test failed or a host self-test failed.

SELF TEST FAILED

A self-test failed after a configuration change.

TEST OK

A self-test requested by the host is successful.

SELF TEST OK

A self-test is successful after a configuration change.

TEST OK NOWRP

A manual self-test without tel wrap plug is successful.

TEST OK WRAP

A manual self-test with tel wrap plug is successful.

DEFAULT CONFIG

Operation intervention is required to reconfigure the CSU/CSU.

Manual Tests

The following manual tests are all initiated from the PKD:

	Data disruptive
• Local loop back	yes ¹
• Local self-test	yes ¹
• Digital test (transmit/receive test)	yes ¹
• LIC line analysis procedures (LLAP)	yes

¹ Run continuously until keying 'EXIT'.

Descriptions of the above manual tests are given later in this chapter, under 'Problem Determination Aid' for LIC type 5 and LIC type 6.

PT2/3

A 10-pin connector is available on the LIC type 6 panel to connect a PT2/3 used to investigate and record control and data signals.

Problem Determination Aid for LIC Types 1 to 4

In addition to the TSS diagnostics, several aids are available to help in problem determination on a line or TSS problem:

- Line interface display (LID) function (refer to *Advanced Operations Guide*, SA33-0097).
- Wrap tests (WTT) function (refer to “Wrap Tests Controlled from the MOSS” on page 4-94 and *Advanced Operations Guide*, SA33-0097).
- Control program procedure (CPP) function (refer to *Advanced Operations Guide*, SA33-0097).
- TSS services (refer to *3745 Service Functions* manual, SY33-2069).
- Traces: external, internal SIT traces, checkpoint trace, NCP line trace.
- TSS dump.
- Port swap (refer to *Advanced Operations Guide*, SA33-0097).

Note: Internal SIT trace and TSS dumps can be transferred via RSF to be analyzed remotely by the PST CE.

Intermittent Error Messages or Messages Lost

Intermittent error messages or messages lost without alarm or BER-created, may come from an intermittent hardware failure of the LIC card or of the CSC card (data bit failure).

For that kind of symptom, run diagnostics to isolate the FRU:

- A LIC card hardware failure affects only the one to four lines of this LIC.
- A CSC card hardware failure, affects all lines attached.

Wrap Tests Controlled from the Host

Below are the different wrap test possibilities from the TSS to the terminal.

The wrap tests at the DCE (or NTT) cable level are part of the line functions and are described in the *3745 Advanced Operations Guide, SA33-0097*.

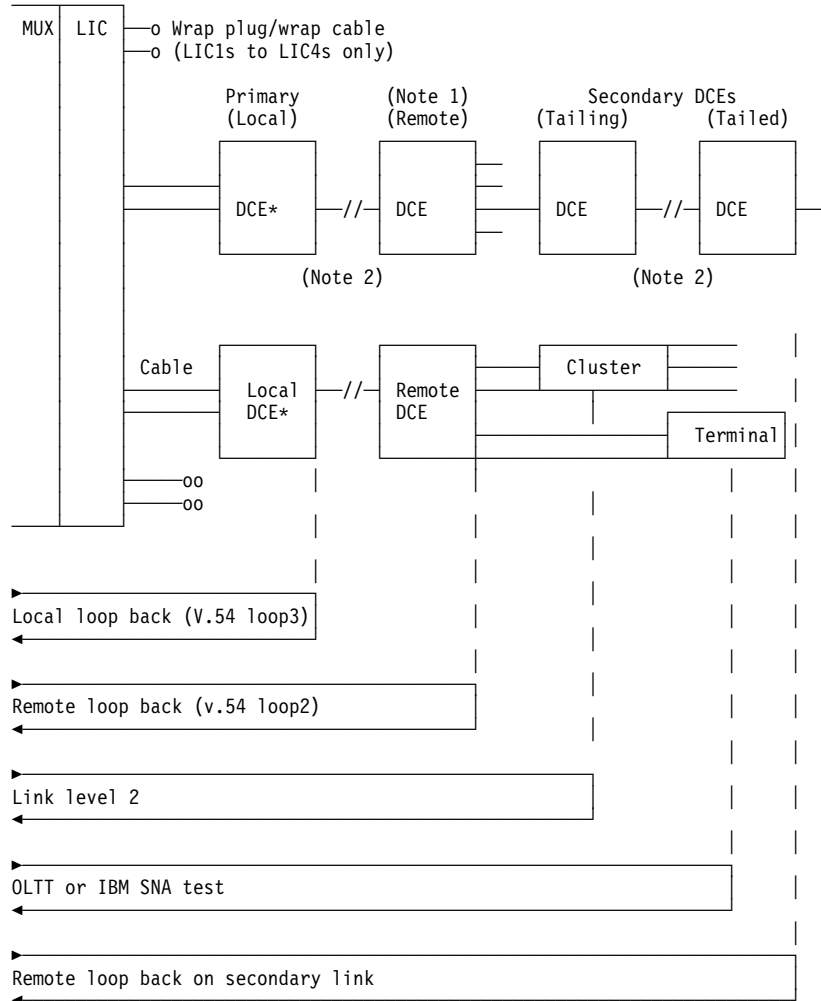

* Stand-alone for LIC type 1 to LIC type 4
Integrated for LIC type 5 and LIC type 6.

Notes:

1. The primary DCE is equipped with the data multiplexing feature or FIFO feature.
2. The telecommunication line is a 4-wire non-switched or switched line.

Wrap Tests Controlled from the MOSS

Below are the wrap tests controlled from the MOSS.

The wrap tests at DCE (or NTT) cable level are part of the line functions and are described in the *3745 Advanced Operations Guide*, SA33-0097.

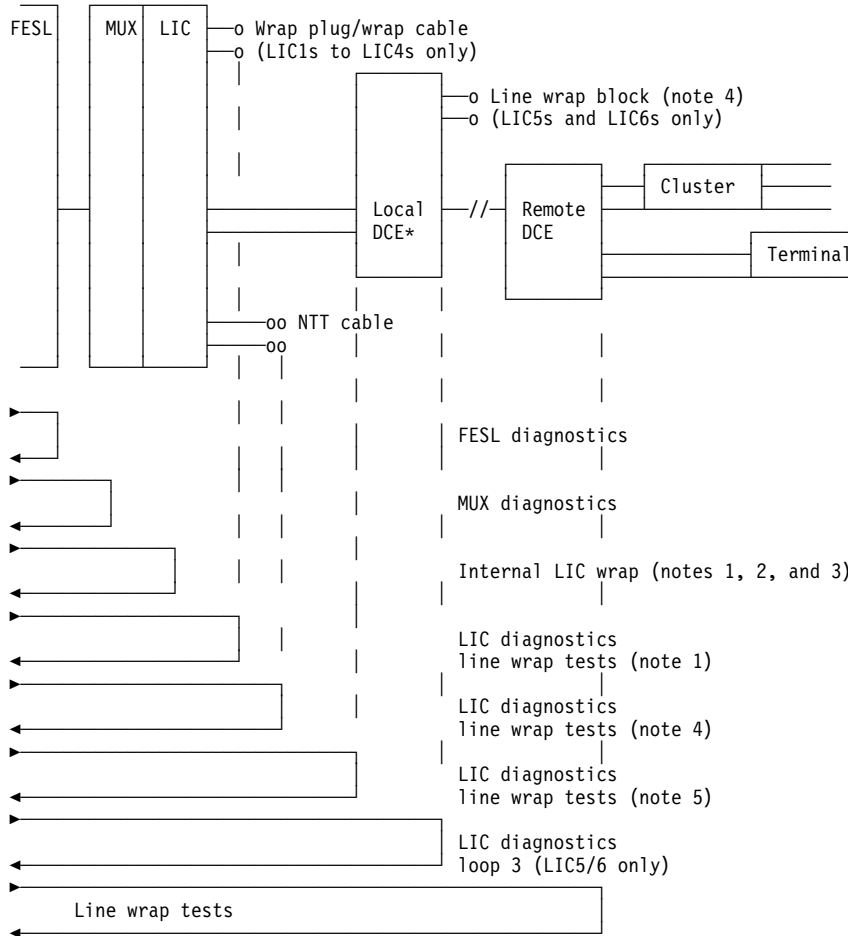

* Stand-alone for LIC type 1 to LIC type 4
Integrated for LIC type 5 and LIC type 6.

Notes:

1. A line position can be plugged with a line cable, with a wrap plug (LIC type 1, 2, 4) or with a wrap cable (LIC type 3).
When the TSS diagnostics are run, the hardware for a selected line is:
 - Tested up to the LIC drivers.
 - Fully tested if a wrap plug or a wrap cable is present on the selected line.
Plugging a wrap plug or wrap cable selects the section 'RC'.
2. During LIC wrap mode operation, the transmit data line and the control lines are not deactivated at the DCE interface (the DCE may be power ON or OFF).
3. Although this is not a user-activated test, an 'echo-check' mechanism (inline) checks the transmitted data in wrap mode.
4. For manual intervention routines, refer to *Maintenance Information Procedures*, SY33-2070.

5. If the cable is NTT with the connector switch set to 'operate', the test indicator (TI) signal is not forwarded to the connected DCE, so that the received pattern differs from the expected one.

Problem Determination Aid for LIC Type 5 and LIC Type 6

Wrap Tests Controlled from the Host

To test the DTE part of a LIC type 5 and LIC type 6, these tests are the same as for LICs type 1 to LICs type 4. See page 4-93.

Wrap Tests Controlled from the MOSS

To test the DTE part of LICs type 5 and LICs type 6, these tests are the same as for LICs type 1 to LICs type 4 (see page 4-94). In addition, the following tests are available:

- Wrap test up to DCE output (with or without line wrap block).
- Self-test (which occurs before 'control lead wrap' command takes place).
- LIC line analysis procedures (LLAP).

See the *Advanced Operations Guide*, and the *Problem Determination Guide* for details.

Manual Tests Controlled from the PKD

To test the DCE part of the LIC type 5 and LIC type 6, all the following tests are manually initiated from the PKD:

Manual Test	Data Disruptive	LIC Type 5	LIC Type 6
Local loop back	Yes ¹	*	*
Remote loop back	Yes ¹	*	
Local self-test	Yes ¹	*	*
Local status	No	*	
Remote self-test	Yes	*	
Remote status	Yes	*	
Digital test (transmit/receive test)	Yes ¹	*	*
Analog test (line analysis)	Yes	*	
LIC line analysis procedures (LLAP)	Yes	*	*

Notes:

1. The above tests run continuously until keying 'EXIT'. See the *Connection and Integration Guide* for details.
2. The process of the 'status bits' from the PKD is independent from the LPDA-2.

They are:

- Alarm tone received (remote DCE power loss)
- Alarm tone received (remote DCE failure)
- Carrier loss

- DCE re-initialization.

Local Loop Back (Loop 3)

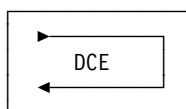

The DCE transmitter is wrapped to the DCE receiver, through the whole analog front-end section, except the line driver and receiver.

Receiver is set compatible with the transmitter, that is, for a multipoint control DCE, the receiver is set to multipoint tributary.

This test is a CCITT loop 3 wrap. It is the host's responsibility to send data under RFS control, and check receive data when CD is ON.

Remote Loop Back (Loop 2)

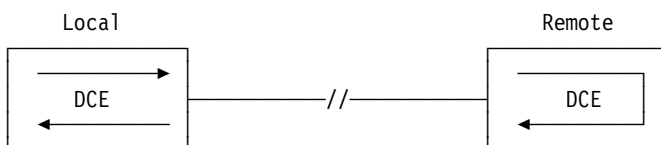

The DCE modem performs a digital loop, sending back the data it is receiving from the line. It is executed in CCITT mode only.

This test is a CCITT loop 2 wrap. It is the host's responsibility to send data under RFS control, and check receive data when CD is ON.

Local Self-Test for LIC Type 5

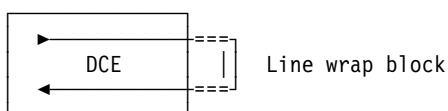

A line wrap block may be plugged into the line interface to allow line interface checking.

If the line wrap block is not plugged when 'local self-test' is selected from the PKD, a 'remote power loss' indication may appear at the remote DCE.

During the test execution, TI is raised at the local DTE interface, CD and RFS are dropped, and the data traffic through the DCE is interrupted.

DSR is dropped if DTR was OFF; otherwise DSR is kept ON.

During the test, the same sequence of operations is continuously repeated. The number of such cycles already performed since the beginning of the test is continuously displayed and incremented. Whenever an error is encountered, the test

stops, the number of cycles is preserved, and an error code may be displayed by pressing the 'GO' key.

If during a self-test, the remote DCE sends an alarm tone, this tone is ignored by the DCE in self-test.

Local Self-Test for LIC Type 6

This tests checks the following components/functions:

- Microprocessor
- ROS
- Internal and external RAM
- NVRAM (RAM part and configuration parameters)
- Read/write registers
- DTE module
- Line loop circuitry
- SDLC adapter
- Alarm signal (transcode test)
- CSU (stress test).

This test is automatically performed at each power ON. In this case, a check of the CMOS modules LSSD string hardware is added.

If an error is found during the tests of the configuration parameters in the NVRAM (checksum error which could be due to a blank area), then:

1. A default configuration is transferred from the RAM in the NVRAM.
2. The indication is recorded for a future LPDA-2 report if applicable.
3. The LIC type 6 is put in idle mode.
4. A warning is displayed.

Remote Self-Test

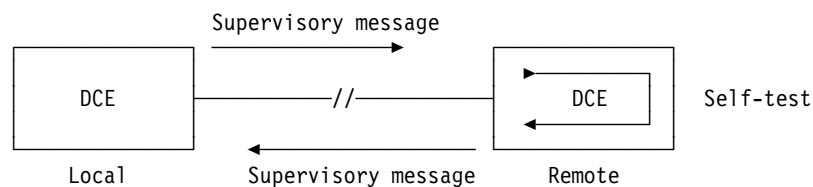

A supervisory message is sent from the local DCE to the remote (along with the DCE address). On reception of this message, the addressed DCE starts a self-test (less than 5 s) and sends back the result of the test in a supervisory message.

During the test execution, 'WAIT' is displayed on the local and the remote DCEs, TI is raised, RFS and CD dropped at the local and remote DTE interfaces, and the DATA traffic through the DCEs is interrupted.

DSR drops at the local DCE, if DTR is OFF.

At the end, a report is displayed on the local DCE and normal background information on the remote DCE.

If the request causes the remote DCE to fail, the alarm tone is sent, and a report is displayed.

If a non-productive time out occurs after the request, a report is displayed.

Local Status

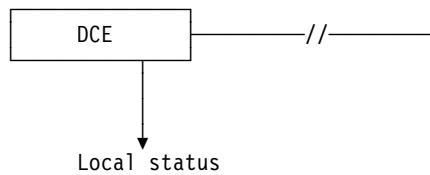

When initiated on the local DCE, the following information is displayed:

- Local line status (current quality, number of hits within the last 15 mn, warnings logged, current receive level)
- Local DTE interface status and activity.

Data traffic through the DCE is not interrupted. Normal operation take place at the DTE interface and TI is **not** raised. Then this test displays line quality and received level, until the 'STOP' key is pressed, or a 30 s time out is reached.

Any LPDA-2 command issued to the DCE from the DTE is ignored (TI is kept OFF).

Remote Status

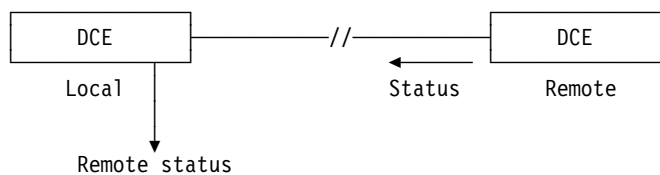

When initiated on the local DCE, along with the remote DCE address, the following information is received (within 5 s maximum) and displayed at local DCE in the following sequence:

- Remote line status (current quality, number of hits within the last 15 mn, warnings logged, current receive level).
- Remote DTE interface state and transition since the last request.

During execution, TI is raised, RFS and CD dropped at the local and remote DTE interfaces, and the data traffic through the DCE is interrupted.

At local and remote DCE, DSR drops if DTR is OFF; otherwise, DSR is kept ON.

Digital Test (Transmit/Receive) for LIC Type 5

Loop test with a tributary station is performed in chopped carrier mode and half-duplex protocol. This protocol allows different inbound and outbound speeds in the control DCE of a multipoint network.

For each test 16 blocks (256 bytes each), are transmitted in each direction. The blocks missed or in error, are counted as erroneous.

In point-to-point, the test is run in continuous carrier operation.

During the test execution, TI is raised, RFS and CD dropped at the local and remote DTE interfaces, and the data traffic through the DCE is interrupted.

DSR drops at the remote DCE, if DTR is OFF.

This test loops on local and remote error counters, until the 'STOP' key is pressed.

Digital Test (Transmit/Receive) for LIC Type 6

This test, which is not protocol-transparent, can be selected only if LPDA-2 is enabled. During this test, local and remote DSU/CSUs exchange predefined bit patterns.

Analog Line Analysis Test

Causes the DCE, after about 10 s, to display some parameters of a telecommunication line between two DCEs (defined as local 'L' and remote 'R').

At test initialization some parameters are already available, because they are derived from data signal and continuously carried out during normal transmission, these values are inserted into line analysis report.

The other parameters are measured during the test itself:

- Data driven parameters:

- Received level 'RL'
- Minimum received level (last 15 mn) 'MRL'
- Number of impulse hits (" ") 'HIT'
- Number of line breaks (" ") 'LBK'

Larger than 10 dB below average value, for a duration longer than 10 ms (typical values).

- Impairments measured during test:

- Line round trip delay, 'RTD'

Measured at local side, is the difference between command sending and acknowledgment receiving times. The measure does not include the DCEs passthrough delay.

- Non linear distortion 'H2' and 'H3'
- Signal-to-noise ratio 'S/N'

Measured from a 1004 Hz tone, into voiceband.

- Phase jitter 'PJ'

Phase modulation imposed by the channel to a 1004 Hz tone. Peak-to-peak phase jitter is measured in a 300 Hz bandwidth.

- Frequency shift 'FS'.

LIC Line Analysis Procedures (LLAP)

The LLAP is a set of tests initiated manually from the PKD and which are automatically chained. They are intended to test a communication facility: the line itself and the two DCEs.

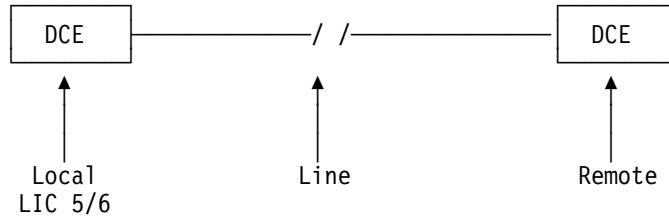

The following areas are successively tested :

- Local self-test
- Local self-test with telephone wrap plug
- Remote self-test
- Local/remote configuration compatibility
- Received and transmitted data activity on both DCEs
- Received line signal quality.

Note: Devices beyond the remote DCE (such as tailed DCEs and lines) are not tested.

Detailed LLAP procedures are described in the *Problem Determination Guide*.

TSS Interface Cables

For details on interface cables and connectors, see the *External Cable References*, SY33-2075.

Chapter 5. High Performance Transmission Subsystem (HPTSS)

The HPTSS in 3745 Models 130, 150, 160, and 170 Data Flow	5-3
The HPTSS in 3745 Model 17A Data Flow	5-4
Introduction	5-5
System Environment	5-5
HSS Packaging	5-5
Line Addressing	5-6
HSS Commands	5-7
Interface Types	5-7
HPTSS Data Flow	5-8
CSP Microcode Summary	5-8
Internal Interconnections	5-10
CSP-to-IOC Bus	5-10
FESH to CSP	5-10
FESH to DMA Bus	5-11
Communication Scanner Processor (CSP)	5-11
Front-End Scanner High-Speed (FESH)	5-12
Transmit Layers	5-12
Receive Layers	5-13
Modem-Out Layer	5-13
Modem-In Layer	5-13
DMA Manager Layer	5-14
CSP Layer	5-14
Scanner Status After the IML	5-14
Reset FESH	5-15
Transmit Operation	5-15
Microcode Functions	5-15
FESH Hardware Functions	5-15
Receive Operation	5-17
Microcode Functions	5-17
FESH Hardware Functions	5-17
Modem Interface Management	5-19
Modem-In Management	5-19
Modem-Out Management	5-20
Modem Retrain	5-21
Time Out Values	5-22
Customization Parameters	5-22
Error Detection and Reporting	5-23
Program/Hardware Checks	5-23
Hardware Error Detection and Reporting	5-23
DMA Interconnection Errors Detected by FESH (Register X'10')	5-24
CSP Interconnection Errors	5-27
FESH Internal Checkers	5-28
Line Interface Check	5-28
Error Status	5-28
Miscellaneous Status Fields	5-31
Status Control Field (SCF) Bit Definition	5-31
Secondary Status Field (SES) Bit Definition	5-31
Line Communication Status (LCS)	5-31
Initial Status Field (ISF) Bit Definition	5-32

Final Status Field (FSF)	5-33
Diagnostic Facilities	5-37
Problem Determination Aid	5-37
NCP Buffer Prefix Validity Checking in Receive	5-37
Problem Isolation and Network Management	5-38
External Wrap Facility	5-38
Communication Interfaces	5-40
FESH-DCE Interface	5-40
Cable Diagrams	5-41
Clocking	5-42
Local Attachment	5-42

The HPTSS in 3745 Models 130, 150, 160, and 170 Data Flow

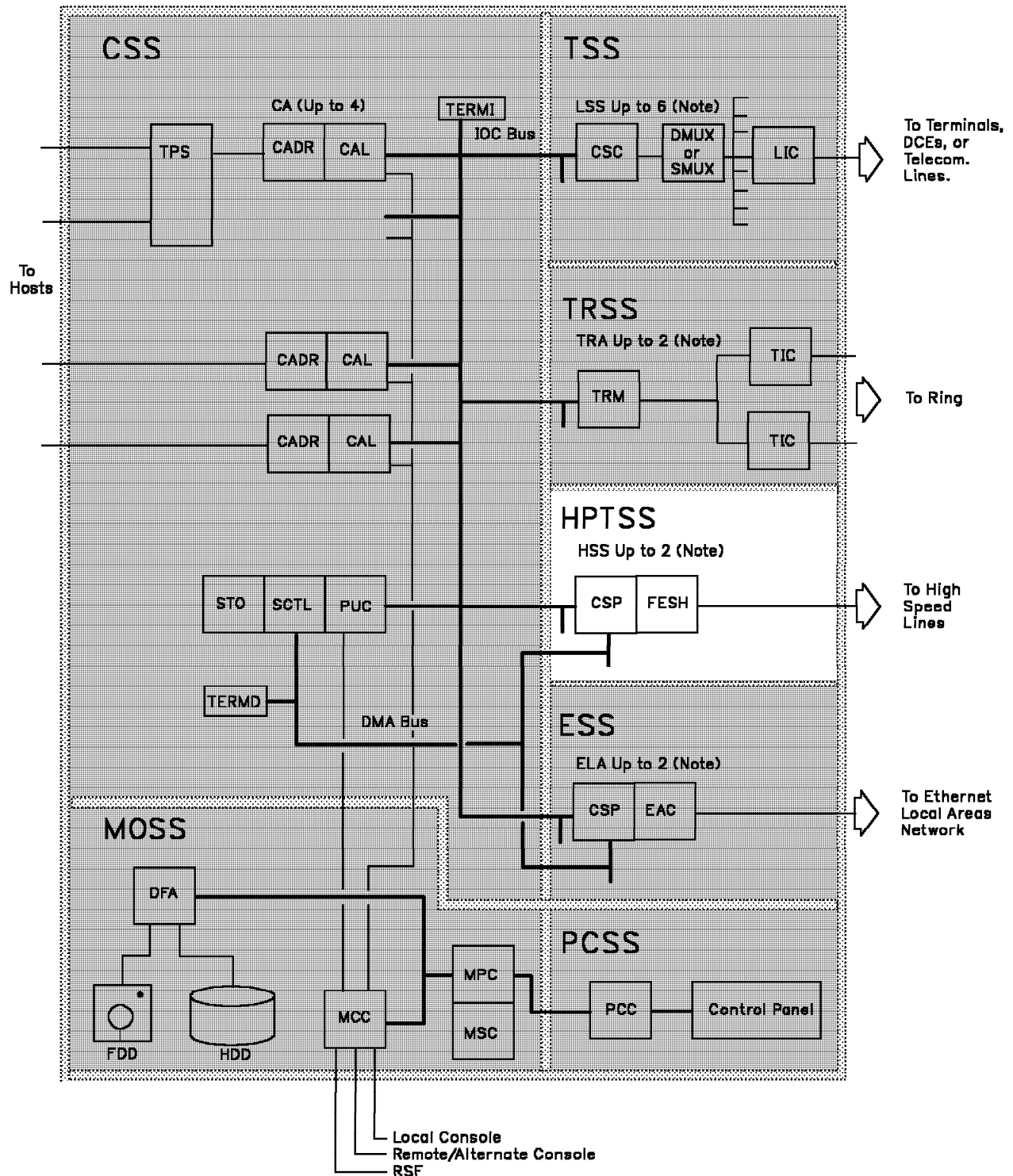

(Note) The number of LSS+HSS+ELA does not exceed 6

The HPTSS in 3745 Model 17A Data Flow

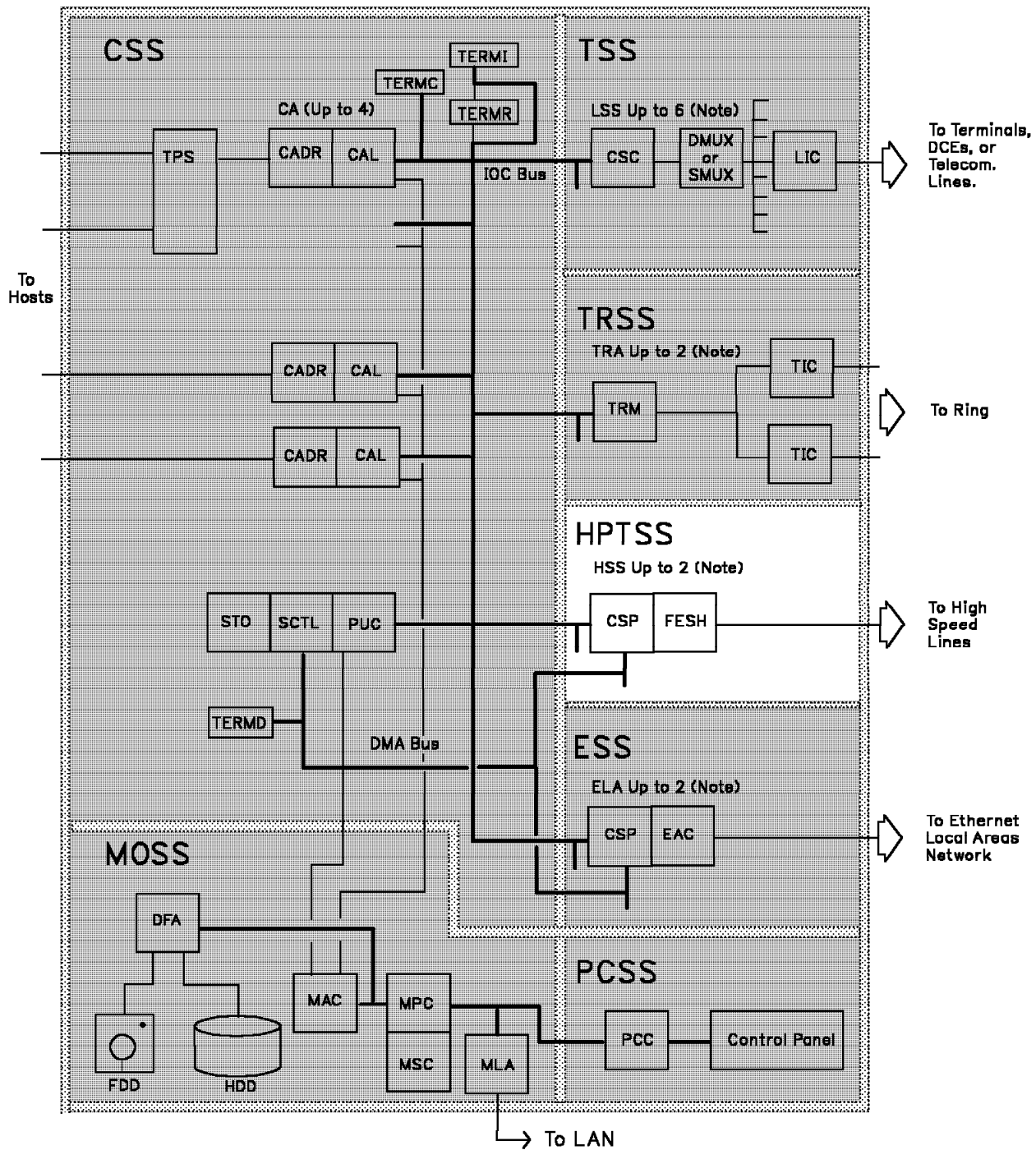

(Note) The number of LSS+HSS+ELA does not exceed 6

Figure 5-1. The HPTSS 3745 Model 17A Data Flow. For model 17A, DMA and IOC buses are connected to the CBC in the 3746-900. This MLA card links the MOSS to the Service Processor through a LAN.

Introduction

The high performance transmission subsystem (HPTSS) is a combination of one or several high-speed link scanners (HSSs) and NCP for the 3745.

The HSS is capable of clear channel, duplex, leased-line, HDLC/SDLC transmission using satellite, Transfix, and any other transmission link (fiber, direct attachment of 3745, 3725, and so on) requiring high-speed data transmission up to 2.048 Mbps. The HSS is also capable of operating with Frame Relay traffic. Included are modifications on the NCP / ESS interface to improve the transmit and receive command performance. This is referred to as the Frame Relay Performance Enhancement (FRPE).

This point-to-point non-switched connection can be attached to any network with the proper network adapter like data communication equipment (DCE) or network communication terminal equipment (NCTE).

The HSS operates with the Network Control Program (NCP) and is transparent to the SDLC data traffic.

System Environment

Since the HSS is transparent to the data, the NCTE or DCE must conform to the network standards. The HPTSS adapters (HSSs) can operate as secondary to the network clock connected to a network. When operating as a secondary, the HSS operates with any clock speed up to 2.048 Mbps.

The HSSs can also be directly connected back-to-back without a network.

When directly attached to each other, the adapters can operate at any one of the three speeds set by the NCP: 245.76 kbps, 1.47456 Mbps or 1.8432 Mbps. The connection to a 3725 is limited to 245.76 kbps.

The HSS provides two separate V.35 or X.21 interfaces to a network.

However, only one V.35 or X.21 interface to the NCTE or DCE can be active and enabled at a time.

HSS Packaging

The handling and management of such a high-speed data link is achieved by two cards:

- One communication scanner processor packaged on one card, the CSP card identical to those of the low-speed scanner (LSS) but with a different CSP microcode load module (Refer to “CSP Microcode Summary” on page 5-8).
- One high-speed front-end scanner packaged on one card, the FESH card.

For board and card locations, refer to the *Maintenance Information Procedures* manual, SY33-2070.

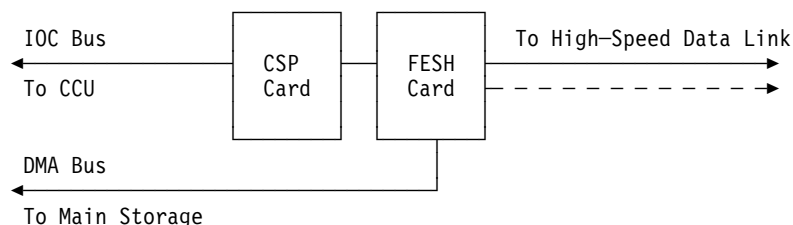

Up to two HSSs (coupled CSP/FESH cards) may be installed on the basic board of the base frame, to control up to two high-speed data links at one time.

On each FESH, a fan-out (standard feature) allows two high-speed data links to be connected at the tail gate to that FESH. But only one of them must be active at a time.

No line interface coupler card (LIC) needs to be installed as for the lines connected to the low-speed scanner (LSS).

Line Addressing

Each HSS supports a maximum of two line addresses. However, only one line at a time may be active in the control program and only one line can be defined using the LKP function.

With two possible HSSs, the maximum number of lines is 4. Line numbers 1028 through 1031 are dedicated for HSS use.

The two lines associated with a particular HSS are addressed by the TD1 field of the IOH. TD1 bit 6 selects one of the two lines. TD1 bit 7 selects either the transmit or the receive interface of the line. TD1 bit 7=0 selects the transmit interface the TD1 bit 7=1 selects the receive interface.

Line Adapter and Port Number		Scanner Line	Line Address	Board Card and Connector Position	Tailgate Position
3	Port 2	1028	404	01G-A1U-J1	01Q-C0-J2
3	Port 1	1029	405	01G-A1U-J2	01Q-C0-J1
4	Port 2	1030	406	01G-A1S-J1	01Q-D0-J2
4	Port 1	1031	407	01G-A1S-J2	01Q-D0-J1

HSS Commands

Commands are set in TD0 of the start line or start line initial instructions. The following NCP commands are supported by the HSS:

Commands	Codes (Hex)
Set mode	01
Enable	02
Disable	03
Change	06
Flush data	09
ResetD	0B
ResetN	0C
SDLC transmit control	10
SDLC transmit data	11
SDLC receive	13
SDLC receive continue	14
Trace	2C
Stop trace	2D
Halt	F0
Halt immediate	F1
Dump Control blocks (no status)	F4
Dump Control blocks (status)	F5

The following MOSS command is supported by the HSS:

Commands	Codes (Hex)
Wrap	2E

Interface Types

Two types of line interface are available at the exit of the FESH card: (Refer to "Communication Interfaces" on page 5-40 for more details)

1. V.35
2. X.21 leased (including French Transfix).

They allow the 3745 to be connected to:

- U.S. T1 type line
- European high-speed lines (CEPT lines)
- Satellites
- In-plant transmission link for direct-attached adapters.

HPTSS Data Flow

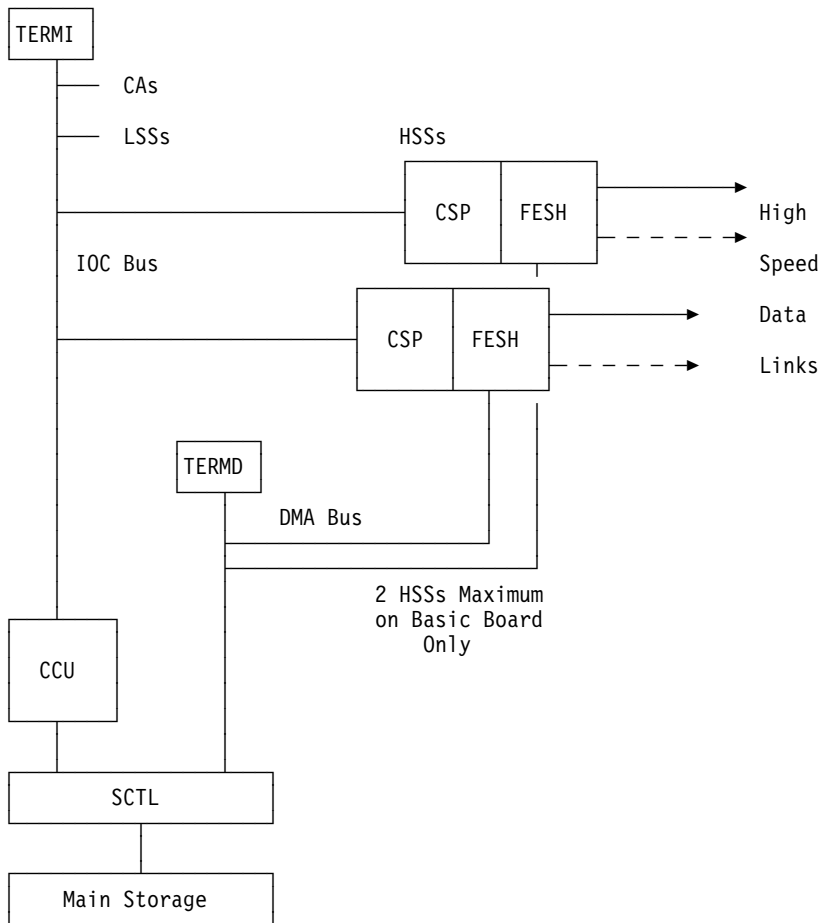

Figure 5-2. HPTSS Data Flow

CSP Microcode Summary

The HSS requires a different CSP microcode load module than the LSS to take advantage of the hardware buffer management for supporting speeds up to 2.048 Mbps.

Listed below are the main microcode functions supported by the HSS.

- Supported line speed: up to 2.048 Mbps
- Supported line interfaces: V.35 and X.21 (called X.21 Transfix in France) leased line
- SDLC/HDLC duplex protocol on point-to-point leased line

A network adapter may be required, such as DCE or network communication terminal equipment (NCTE).

- Echo suppression
- Frame up to 64 kbytes long (SNA maximum size)
- CSP ROS common with other microcode load modules
- SDLC address compare performed by FESH
- NCP buffer prefixes automatically handled by FESH via DMA bus (except for SIT buffers)
- The HSS transfer of data between adapter and NCP differs from the LSS:
 - When the LSS transfers data to the NCP buffers, via the IOC bus, it uses the cycle steal mechanism.

- When the HSS transfers data to the NCP buffers, via the DMA bus, it uses the FESH hardware.
- One PIO per SDLC frame for transmit
- One or several PIOs per SDLC frame are possible for receive
- IOC cycle steal is used for command parameters and status, IML, dump, and SIT trace data.
- Frame Relay duplex protocol attached as a DTE to a Frame Relay network, or as part of the Frame Relay network as a DCE.
- Multiple Frame Relay frames with one transmit PIO.
- One PIO per received Frame Relay frame.
- Use of a SNAP header format table to place Frame Relay headers and data in the proper alignment for NCP in their receive buffers.

Main Differences with LSS

- Buffering of the receive and transmit frames is done in a FESH buffer instead of CSP storage.
- SDLC transmit continue command not supported.
- SDLC receive monitor command not supported.
- No multiplexing (only one line).
- HSS microcode deals with buffer prefixes only with scanner interface trace (SIT). The remaining buffer prefix handling is done by the FESH.
- CCU storage access for NCP buffer data is done through DMA instead of IOC cycle steals as in LSS.

However, IOC is still used for the following:

1. Dump, IML, diagnostics.
2. Sending status (followed by CCU level 2 interrupt) when FESH, DMA or SCTL error has to be reported.
3. Facilities (Refer to “Problem Determination Aid” on page 5-37) invoked from the operator console (MOSS) to:
 - a. Perform diagnostics.
 - b. Access FESH registers and random access memory.
4. IOH transfer between NCP and CSP.
5. MOSS exchange with HSS.

Internal Interconnections

As shown in "HPTSS Data Flow" on page 5-8, each HSS interconnects with the communication subsystem (CSS) and the MOSS via the IOC bus and the DMA bus.

CSP-to-IOC Bus

This connection is used for:

- Communication with the NCP (through the same IOH high level commands as the other LSS scanners)
- MOSS command exchange
- HSS IML
- Diagnostics.

The physical interconnection between the HSS CSP and the CCU is identical to that between the LSS CSP to the CCU (Refer to the Chapter "Transmission Subsystem").

For board and card locations, refer to the *Maintenance Information Procedures* manual, SY33-2070.

NCP-HSS Microcode The CCU uses IOH and IOHI to exchange data, commands and statuses with the HSS CSP in the same way as with the LSS, but cycle steal is not used when the FESH is running.

CLDP-HSS Microcode The controller load/dump program (CLDP) is used in a remote 3745 to interconnect the CCU and the HSS CSP microcode. The main functions performed are:

- IPL of the remote 3745
- Dump of the remote 3745

The CLDP never:

- Issues SDLC transmit continue or receive monitor commands
- Uses data areas, but NCP buffer pointers for both transmit and receive operations.

FESH to CSP

The physical interconnection between the FESH and the CSP is identical to that of the internal interconnection between the FES function and the CSP of the LSS.

For board and card locations, refer to the *Maintenance Information Procedures* manual, SY33-2070.

Microcode to FESH The picocode is loaded from the CSP in each layer of the FESH RAM at IML time. The FESH-to-CSP interconnection is activated and controlled via external registers and control words (CW). A CW is built by the CSP microcode and specifies the actions to be performed by the FESH. The CW is cycle stolen by FESH, then executed. The FESH informs the CSP microcode when the action is completed.

Data Transmission The CSP microcode can issue the following commands to the FESH:

- Start transmit initial
- Start transmit
- Soft stop transmit (For example; it causes the FESH to transmit the error sequence, which is a MOSS init parameter from the NCP)
- Hard stop transmit (For example; it forces the transmit data line to a mark level all ones).

Data Reception The CSP microcode can issue the following commands to the FESH:

- Start receive
- Start receive continue
- Stop receive
- Flush the current frame.

Data and Modem Management The CSP microcode can issue the following commands to the FESH:

- Start modem monitor
- Start modem-out
- Start data management

FESH to DMA Bus

This connection is used for direct CCU storage access and specifically:

- NCP buffer prefix exchange
- Data transfer between the high-speed line and main storage
- Parameters and status exchange between the NCP and the HSS microcode.

Communication Scanner Processor (CSP)

The HSS CSP hardware is identical to that of the LSS CSP (Refer to the Chapter "Transmission Subsystem" for details).

Front-End Scanner High-Speed (FESH)

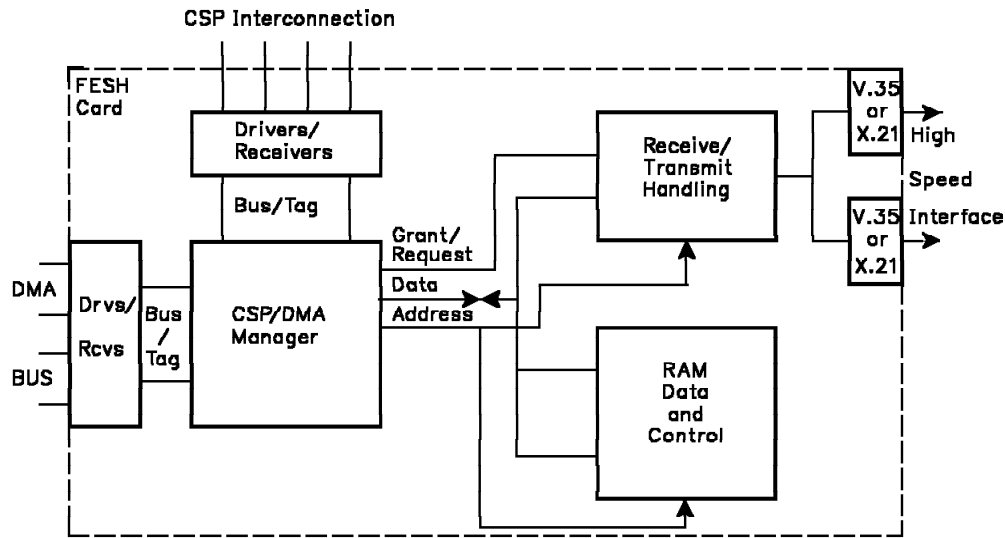

Figure 5-3. FESH Data Flow

The transmit/receive handling of the FESH is functionally organized in layers as follows:

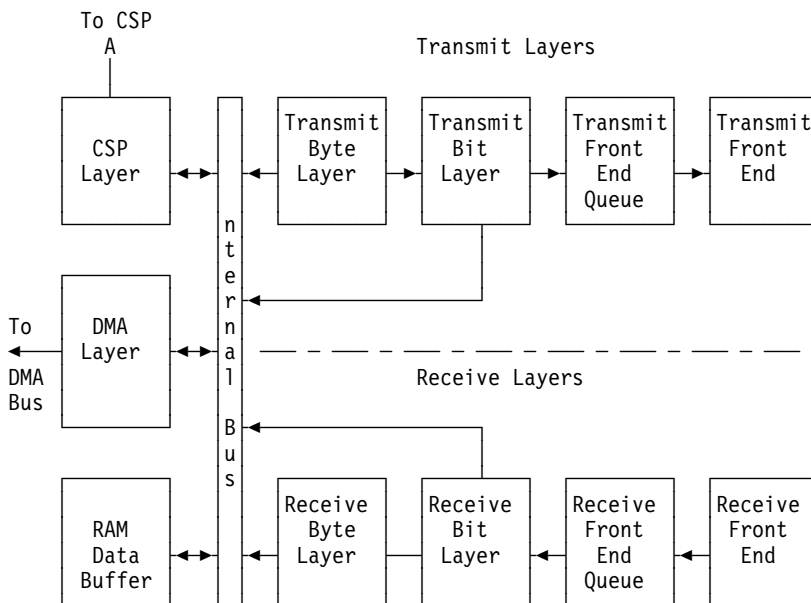

Figure 5-4. Transmit and Receive Layers

Transmit Layers

The transmit layers are composed of:

- The front-end circuits which perform the following functions:
 - Serialization of data
 - Flag generation
 - Zero insertion
 - CRC generation.
- The transmit bit layer which:

- Handles byte transfer between transmit front-end buffers and the FESH RAM.
- The transmit byte layer which:
 - Handles NCP buffer prefixes for transmission.
 - Interconnects with the CSP layer (external registers and control words).
 - Handles chaining thru NCP buffers for SDLC transmits.
 - Handles chaining thru NCP buffers for each frame relay frame and chaining between frames to transmit.

Receive Layers

The receive layers are composed of:

- The front-end circuits which perform the following functions:
 - Deserialization of data
 - Zero deletion
 - Flag detection
 - Early flag detection
 - Abort detection
 - Idle detection
 - Overrun detection
 - CRC calculation error detection
 - Address compare/satellite echo suppression
 - Interconnection with receive queue buffer.
- Receive bit layer:
 - Handles byte transfer between receive front-end buffer and FESH RAM.
- Receive byte layer:
 - Handles NCP buffer prefixes for receive
 - Interconnects with CSP layer (external registers and control words).
 - Handles chaining thru NCP buffers for SDLC receives.
 - Handles chaining thru NCP buffers for frame relay frame receives. Also, use the SNAP header format table to determine the offset and maximum counts to use for the first two buffers in the receive chain for frame relay. Provide the actual count used in the receive buffer prefix.

Modem-Out Layer

The modem-out layer:

- Interconnects with the CSP layer control word (CW).
- Activates output modem control leads according to the modem-out CW prepared by the CSP microcode.

Modem-In Layer

The modem-in layer:

- Interconnects with the CSP layer (control word and external registers).
- Performs input modem control lead status confirmation.
- Reports input modem control lead changes and X.21 steady states according to the modem-in CW prepared by the microcode and stored in the FESH RAM.

DMA Manager Layer

The DMA manager layer:

- Interconnects on one side with:
 - FESH RAM
 - Data management buffer
- Interconnects on the other side with the DMA bus.
- Handles the DMA bus protocol.
- Performs data transfer from/to CCU main storage, to/from transmit/receive/data management buffers.
- Handles priorities of DMA bus requests from transmit/receive data management layers.

CSP Layer

The CSP layer:

- Interconnects on one side with the CSP storage and microcode.
- Interconnects on the other side with the various FESH layers via CSP external registers and cycle steal operations.
- Handles the protocols of CSP external registers and cycle steal operations.
- Handles cycle steal requests from transmit/receive/data management/modem-in/out layers on a priority basis.

Scanner Status After the IML

At the end of scanner IML it is possible to get from the CCU storage, the status of the scanners associated with their mailbox.

The 16-byte mailboxes are located from CCU storage address 3F8000.

The status of the scanners just IMLed are in the last two bytes of the mailbox. These values must be displayed before any mailbox exchange between the CCU storage and the corresponding scanner (for example: CCU functions).

Below are the possible statuses of the scanner after an IML:

Values	Description
X'nnFF'	No answer from scanner following the MOSS command 'nn'
X'C900'	Normal status IML OK
X'C901'	FESH picocode failed
X'C902'	FESH card and picocode level not compatible
X'C904'	FESH card not installed

Figure 5-5. Values of the Last Two Bytes of the Mailboxes after IML

Reset FESH

All latches are reset, the DMA and modem interfaces are disabled, the card is kept in 'freeze mode' (FESH not operational) until the CSP loads the microcode in those storage locations which are not reset.

Transmit Operation

Microcode Functions

The microcode:

- Handles NCP transmit commands through PIO operations on the IOC bus.
- Gets transmit parameters and sends transmit status from/to the NCP via the DMA bus.
- Builds the transmit control word (CW) to be sent to the FESH.
- Indicates to the FESH transmit layer (external register setting) the:
 - Transmission coding mode (NRZI or non-NRZI) at set mode
 - Start of transmit initial
 - Start of transmit
 - Stop of transmit operation (hard and soft).

FESH Hardware Functions

Transmit Initial Command The transmit initial command is used between the CSP and FESH hardware to perform a wrap test on the X.21 interface. The NCP issues a wrap command to the FESH with modifier bits indicating the type of wrap to be performed. Then, the CSP issues the transmit initial command with the loop bit ON to the FESH, to support X.21 network testing, or to send a data pattern other than flags between SDLC frames.

On reception of a start transmit initial command from the microcode, according to a control bit (loop bit), the FESH sends in 'non-zero insert mode' to the transmit line:

- Loop bit OFF:
 - An initial character sequence (7 characters maximum) prepared by the microcode at initialization time.
 - Then, the SDLC frame with the receipt of the transmit command (Refer to the "Transmit Command" on the next paragraph).
- Loop bit ON:
 - The initial character sequence (7 characters maximum)
 - Then sends *the last two characters of the sequence continuously* until the microcode sets the start transmit command or the stop transmit command (used by the X.21 wrap command from the CSP to the FESH).

Transmit Command On reception of a start transmit command, the FESH transmit layer cycle steals the transmit control word prepared by the microcode in CSP storage.: When the control word is loaded, the transmit byte layer:

- For SDLC, cycle steals the A/C fields prepared by the microcode in CSP storage.
- If the SDLC frame contains A/C fields only, the transmit byte layer starts the transmission.
- If the SDLC frame contains an I-field, the FESH begins a DMA operation to load the I-field from the CCU storage to the FESH RAM via the DMA bus.
- For frame relay, begin a DMA operation to load the transmit data from the CCU storage to the FESH RAM via the DMA bus.

Note: The maximum size of an A/C field is four bytes.

The bit layer machine and the byte layer machine operations are overlapped so that the transmission of data can continue while data is being obtained from the CCU via the DMA interconnection.

This overlap of operations continues until a zero buffer pointer is detected.

- When a zero buffer pointer is detected the bit layer instructs the front-end to send the CRC and ending flag, followed by the ending sequence specified at set mode (line at mark or continuous flags).
- If frame relay, look for another frame to transmit. If there is one, continue as if starting a new frame. Continue as in the previous bullet until all frames are transmitted.
- The byte layer also sets the end of transmit bit in the transmit status register and generates a level 2 interrupt to the CSP.

During the transmission over the line, the hardware may detect that no data has been loaded in the external RAM whereas the FESH bit layer requests a new buffer (DMA transfer up to the buffer count not completed), in that case the hardware:

- Sets the underrun and the end transmit bits in the transmit status register.
- Raises a level 2 interrupt to the CSP.
- Sends the transmission error sequence initialized at set mode.

Soft Stop Transmit Command On reception of this command, the hardware:

- Stops transmitting the data.
- Stops any transmit DMA transfer in process.
- Sends the transmission error sequence initialized at set mode.

Hard Stop Transmit Command On reception of this command, the hardware:

- Stops transmitting data.
- Stops any transmit DMA transfer in process.
- Puts the line at mark.

Receive Operation

Microcode Functions

The microcode:

- Handles NCP receive commands through PIO operations on the IOC bus.
- Gets receive parameters from the NCP.
- Sends receive status from/to the NCP through data management exchanges on the DMA bus.
- Prepares the receive control word (CW) for the FESH:
 - The CSP cycle steals the storage address of the received SDLC frame address/control fields.
 - If a non-I frame is to be transmitted, the number of bytes of the A/C field is indicated(4 bytes maximum).
- Indicates to the FESH (external register setting) the:
 - Transmission coding mode (NRZI or non-NRZI) at set mode
 - Start of receive command
 - Receive continue command
 - Stop of receive operation command
 - Flush command.

FESH Hardware Functions

Receive Command When the FESH is enabled it always:

- Monitors for flag (flush other characters).
- Performs address compare.
- On flag recognition, starts accumulating received characters in the receive queue buffer.
- Performs zero deletion.
- Performs CRC accumulation (The two CRC characters are not stored in the receive queue buffer).
- On flag recognition, checks the CRC.
- Stores the receive ending conditions in the receive queue buffer and then in external register X'10' for the microcode:
 - End of receive CRC OK
 - End of receive CRC bad
 - Flag OFF boundary
 - Abort (not followed by idle)
 - Idle
 - Overrun.
- Accumulates multiple frames in the receive buffer queue.
- If receive queue full:
 - Indicates overrun as ending condition in receive queue.
 - Flushes further incoming characters of the frame on which the overrun occurred.
 - Ignores subsequent data and flags until the CSP issues a receive command.

Receive Flow On reception of a receive command from the microcode, the FESH receive layer:

- Cycle steals the receive control word (CW) prepared by the microcode in CSP storage.

When the CW fetch is completed, the receive byte layer:

- Cycle steals the A/C field into CSP storage starting at the address specified in the receive CW.

If the ending condition is reached (no I-frame) the byte layer:

- Generates a level 2 interrupt to the CSP.

If no ending condition is detected in the receive queue (I field), the following operations are performed.

Receive Operation For I-Frame:

The receive operations are overlapped so DMA operations are done in parallel with the extraction of the data characters from the transmission line.

The process is continued until the ending condition is detected.

End of Receive:

When an ending condition is detected in the receive queue, the byte layer sends the address of the last NCP buffer used, plus the residual byte count of the last buffer, in CSP storage, and generates a level 2 interrupt to the CSP.

Receive Continue Command (SDLC only) During the receive flow, the byte layer detects the end of message:

- Stops reading characters from the receive queue, but the FESH continues receiving characters from the line.
- Raises an interrupt to the CSP and indicates to the microcode that a new buffer pool is needed.
- Waits for start receive continue from the microcode.
- On reception of start receive continue from the microcode, the hardware resumes the normal process.

Flush End of Frame Command When receiving I-frames to be flushed, a 'frame reject' frame (FRMR) can be received and must not be flushed. For this purpose, the NCP issues a receive command to get the A/C field of the received frame.: In that case the FESH performs an action similar to the receive continue process and:

- Stops reading characters from the receive queue after having sent the A/C fields into CSP storage.
- Raises a level 2 interrupt to the CSP and indicates to the microcode that a new buffer pool is requested.
- Waits for start receive continue from the microcode in case of FRMR frame, or for a flush end of frame command.

Flush Command On reception of this command, the hardware reads and flushes the remaining data characters of the frame out of the receive queue, until an ending condition is reached. This ending condition is reported to the microcode.

Stop Receive Command On reception of the stop receive command from the microcode, the hardware clears out the contents of the receive queue buffer.

Modem Interface Management

Modem-In Management

To manage the DCE input leads, the microcode:

- Prepares a CW in CSP storage.
- Starts the process by sending the start modem monitoring command to the FESH.

The modem-in layer monitors the modem input leads.

On a modem control lead change, according to the CW, and after possible lead state confirmation, the modem-in layer interrupts the microcode (level 2 interrupt) which can then get the modem input lead status at the time of the change.

After a modem change has been reported to the microcode, the hardware does not report a new change until the microcode sends a new modem-in monitoring command.

Confirmation parameters are defined in the configuration data file and are loaded in the FESH at initialization time.

V.35 Modem-In Lead State Confirmation On V.35 lines, the FESH is capable of monitoring:

- Data set ready (DSR)
- Clear to send (CTS)

However, in normal operation, the CSP microcode only monitors the DSR and CTS leads.

The FESH modem-in layer starts a count before delivering the new modem-in value to the CSP, in order to avoid unwanted interrupts caused by modem-in leads bouncing, or specific DCE behavior.

The confirmation delay is adjustable by the customer, through the CDF function, to adapt to the DCE characteristics.

DSR Confirmation:

Confirmation is performed on DSR going ON and OFF.

The confirmation delay is specified for each signal in a 3-bit parameter field loaded by the microcode. A specific timer starts each time the associated signal switches. The change is confirmed when the timer elapses.

Parameter Value	Confirmation Delay
0 0 0	No delay
0 0 1	1 ms
0 1 0	4 ms
0 1 1	16 ms
1 0 0	32 ms
1 0 1	64 ms
1 1 0	128 ms
1 1 1	256 ms

Note that the actual confirmation delays can be greater than the above values due to the fact that the timers restart at each signal change.

CTS State Confirmation:

The CTS state confirmation is set in indirect register X'09'.

The transmit clock and the transmit data requests made to the bit layer are gated by CTS in the FESH, in order to perform data transmission only when CTS is ON (refer to "Modem-Out Management" and "Modem Retrain" on page 5-21 for explanation). However, this gating can be disabled by the microcode.

CTS drop reporting can be controlled by the microcode.

One timer step value is available:

- 400 ms step

If the timer value is zero (default value), CTS drop is reported without delay.

If this value is not zero, the hardware handles CTS drop according to the timer value. If the timer expires (25.2 s maximum) before CTS drops, a modem-in change is reported.

X.21 Modem-in Lead State Confirmation In X.21, the modem-in microcode layer immediately reports to the microcode any change of the X.21 steady states and performs, in parallel, the confirmation of the following steady states which are detected by the FESH hardware:

	I	R
Clear	OFF	0
Controlled Not Ready (CNR)	OFF	0/1 (16-bit time)
Controlled Ready (CR)	OFF	1
Ready for Data (RD)	ON	X (don't care)
Local Wrap (LW)	OFF	X'0F' data received (16-bit time)
Remote Wrap (RW)	OFF	X'33' data received (16-bit time)

To confirm any state, the hardware verifies that the state remains unchanged during a count of 16-bit times.

When a state is confirmed, a modem-in change is reported to the microcode with the indication steady state ON.

DCE Clock Failure The hardware monitors the receive and transmit DCE clocks of each line to detect clock failures.: If one or both DCE clocks disappear during a period of time exceeding 2.5 s, the FESH reports a clock failure to the microcode in indirect register X'11' (no level 2 interrupt is sent to the CSP).

Modem-Out Management

To manage the DCE output leads, the microcode prepares a CW in CSP storage and starts the process by setting the send modem-out command to the FESH.

On reception of this command, the hardware activates the output leads according to the contents of the CW.

The microcode can, at any time, read the modem-out lead register which contains the output leads activated by the hardware.

Modem Retrain

The term 'modem retrain' is used here to mean the temporary inability of a modem to respond to requests from the attached business machine (DTE). On V.35 lines, this typically occurs when two modems lose carrier synchronization. While 'retraining' the carrier, they are unable to provide service.

On X.21 lines, a 'retrain' means that the network or DTE places the line under test and during this time, the line is unable to provide service.

V.35 Modem Retrain 'Modem retrain' is detected on V.35 lines as a drop of clear to send (CTS). When this occurs:

1. The FESH starts a timer derived from the set mode enable time out value.
2. The FESH continues any transmission until the end of message is reached.
3. If a transmission is in progress when CTS drops, and the retrain timer has not expired, the following ending status is sent to the CCU when the transmission completes:
 - SCF = X'22' (underrun/data transmitted)
 - SCF = X'20' (underrun)
 - SES = X'80' (modem retrain)
 - LCS = X'00'
4. If CTS does not recover, and the retrain timer expires while a transmission is in progress, the ending status sent to the CCU is:
 - SCF bit 3 = 1 (modem check)
 - LCS = X'E2' (CTS dropped)

If CTS does not recover, but there is no transmission in progress, the error will be detected and reported on the next transmit command as:

- SCF bit 3 = 1 (modem check)
 - LCS = X'F2' (CTS failed to come up)
5. Data reception is not affected.

X.21 Modem Retrain On X.21 lines, modem retrain is entered when a DCE uncontrolled not ready or DCE controlled not ready steady state is detected. When this occurs:

1. The CSP microcode starts a 20 second timer.
2. The FESH continues any transmission until the end of message is reached.
3. If a transmission is in progress when the retrain starts, the following ending status is sent to the CCU when the transmission completes:
 - SCF = X'22' (underrun/data transmitted)
 - SCF = X'20' (underrun)
 - SES = X'80' (modem retrain)
 - LCS = X'00'
4. If data reception is in progress when the retrain starts, the incoming frame is flushed (to avoid filling the NCP buffers) and the receive command is ended with the following status:
 - SCF = X'04' (end of message)
 - SES = X'10' (data check)
 - LCS = X'00'
5. If the DCE does not return to a 'ready' or 'ready for data transfer' state before the time out expires, the following ending status is sent to the CCU:
 - SCF bit 3 = 1 (modem check)
 - LCS = X'EE'

Time Out Values

The following is a list of the various timer values used by the HSS along with their sources:

- Enable time out** Taken from the set mode data, it is used during enable command execution and also during transmit command execution (to monitor CTS, if it is down).
- Disable time out** Taken from the set mode data, it is used during disable command execution to allow the modem, time to respond to the changes on the modem-out leads.
- Reply time out** Taken from the set mode data, it is used during receive command execution to monitor for a reply to a transmission.
- DSR confirmation** A MOSS init value, it confirms a steady state on DSR for the stated period.
- X.21 modem retrain** A fixed 20-second value.
- V.35 modem retrain** The enable time out value is used if it is less than or equal to 25.2 seconds. A retrain timer of 25.2 seconds is forced if the enable time out exceeds this value. If the enable time out is not a multiple of 400 ms, the modem retrain timer is rounded to the next 400 ms increment.
For example:

Enable time out	Resulting retrain value
0 ms	0 ms
100 ms	400 ms
400 ms	400 ms
25.2 s	25.2 s
40 s	25.2 s

Customization Parameters

Using the CDF Display/Update option 1 at the MOSS console, the CE or the customer can have access to the HSS parameters. The CE or the customer can choose two parameters: the DMA size (see note 3 hereunder) and the DSR integration timer.

The DMA size (see note 3 hereunder) is a function of the number of HSS line adapters installed. A DMA size of 64 is correct for one HSS line adapter installed.

The DSR integration timer is a function of the manufacturer's equipment attached to the network. Normally 16 ms is adequate.

However, the CE or the customer must read the manufacturer's installation guide to determine if 16 ms can be used.

The following parameters are default values for the HSS port:

- DMA size (see note 3 hereunder) (2 to 64, even values only): 64
- Error sequence: 7FFF
- DSR integration timer (0, 1, 4, 16, 32, 64, 128, 256): 16

Notes:

1. The DMA size and error sequence are valid for attachment to the X.21 or V.35 interface for the SDLC protocol.
2. The integration timers are valid only for the V.35 interface.
3. DMA size (length of burst. Depending on the 3745 microcode level, this field may no longer be displayed and modifiable. Its default values are set as follows:

64 for receive operations

253 for transmit operations.

For frame relay, the DMA burst size parameter is not used. The DMA burst size used by the FESH is dependent on the NCP buffer size.

Error Detection and Reporting

Program/Hardware Checks

In addition to the program/hardware errors reported in the command status via level 2 interrupts, the CCU may be notified by a CCU level 1 interrupt that a program or hardware check occurred.

To obtain the error information, the control program issues a get error status instruction, which transfers a two-byte error status to the CCU.

The control program also resets the check and the interrupt, and performs the recovery actions. The following conditions may cause a level 1 program or hardware check:

1. CCU/HSS problems:

- IOH/IOHI instruction not supported.
- IOH/IOHI rejected because there is already an outstanding command on the interconnection. For example, a second transmit command has been sent while a transmit command is already outstanding.
- IOH/IOHI rejected because a set mode command has not yet been received for that line.
- Abnormal conditions detected during I/O operations on the IOC bus. These errors may be detected by the CCU or by the HSS. Errors are related to CCU storage and address checks, invalid sequences, and timed-out IOH/IOHI instructions.

2. HSS problems:

- Invalid interrupts.
- Microcode-detected program failures. (These set the microcode check bit in the error status and cause the NCP to issue a get microcode check instruction.)
- CCU level 2 interrupt stack overflow.
- CSP or FESH hardware check (for example parity or address check).

After receiving a level 1 interrupt from the FESH, the CSP microcode, builds the error status, freezes the FESH, and waits for the get error status IOH.

Once the get error status has been answered, the CSP enters the disconnect/stop environment and ignores all IOH instructions generated by the NCP. Re-IML of the CSP microcode is required to return to an operational state. The only exception to this sequence of events is a level 1 interrupt caused by a command reject.

Refer to "Error Status" on page 5-28 for the error status description.

Hardware Error Detection and Reporting

Two types of error:

- DMA and modem interface errors which raise the level 2 interrupt to the CSP.
- Errors which raise the level 0 interrupt to the CSP.

Internal Box Error (IBE) Reporting The internal box errors generate box event records (BERs). For details on BERs, refer to the "Box Event Records (BER)" Chapter.: The IBEs can be divided into three categories:

1. CSP and FESH internal errors or events (similar to the errors defined for the CSP/FES in the LSS):
 - Adapter interconnection check
 - CSP interconnection error
 - FESH failing to answer
 - No interrupt from FESH
 - Invalid interrupt from FESH
 - Command rejected
 - Trace already active (event, not error)
 - FESH internal error
 - Local attach clock failure
 - AIO error
 - Line not accessible (one of the two possible lines is already active)
2. DMA errors detected by the FESH:
 - DMA parity error during write or read
 - DMA time out during write or read
 - DMA burst count error
 - DMA interconnection errors for improper DMA tag sequence.
3. Errors detected in the SCTL card:
 - Storage internal error
 - SCTL internal error
 - DMA internal error
 - DMA logical error
 - DMA storage protect/address exception
 - DMA interconnection error in read or write (a)
 - DMA parity check. (b)

Notes:

1. The following errors can occur concurrently:
 - a and b
2. All the above-listed errors are reported to the NCP via a level 2 interrupt and associated status area as an LCS and ELCS code (Refer to "Line Communication Status (LCS)" on page 5-31 and "Extended Line Communication Status (ELCS) (Initial Status=B'110') for HSS" on page 5-35 for code description).
3. The SCTL errors and the FESH DMA interconnection errors are mutually exclusive. There is no double-reporting of errors.

DMA Interconnection Errors Detected by FESH (Register X'10')

DMA Tag Sequence The FESH circuitry monitors the sequence of the DMA interconnection signals from the SCTL card.: An error is reported when the tag sequence does not occur properly.

DMA Data Bus Parity Checker This parity checker verifies the validity of the data received/sent, from/to the DMA data bus byte 0 and byte 1 by the FESH.

DMA Time Out One hardware timer is implemented to detect possible time out conditions on the DMA bus. The duration of the timer is in the range of 100 ms to cover a complete transfer operation on the DMA bus.

DMA Burst Count Checker This checker verifies that the transfer is satisfactorily completed on the DMA bus when the burst count in the FESH reaches zero.

SCTL Card Detected Errors Reported By FESH The SCTL card has internal checkers which detect the following error conditions which may occur during a DMA transfer initiated by an HSS (Refer to the figure "Line Error Hexadecimal Code" next):

Line Error Hexadecimal Code	SCTL Error Conditions					
	a	b	c	d	e	f
0	Normal mode (no error)					
1	x					
2		x				
3			x			
4				x		
5					x	
6						x
7						

Figure 5-6. Line Error Hexadecimal Code

- SCTL error detection:
 - a. DMA internal error
 - b. DMA logical error
 - c. DMA storage protect/address exception error
 - d. Storage unrecoverable error or control error
 - e. DMA interconnection error
 - f. DMA parity check

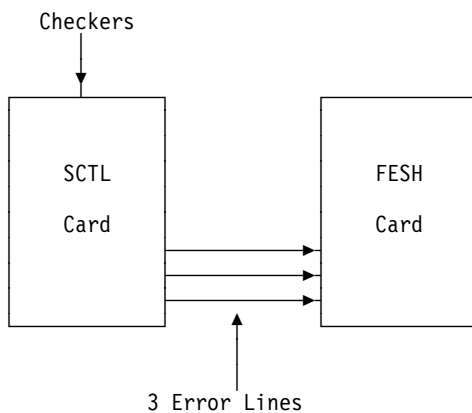

Reporting Reporting DMA errors is done by issuing a level 2 interrupt to the CSP. The nature of the error is set into an LCS/ELCS (Refer to "Line Communication Status (LCS)" on page 5-31 and "Extended Line Communication Status (ELCS) (Initial Status=B'110') for HSS" on page 5-35 for code description).: When any of the above checkers becomes active:

1. The hardware:
 - Stores the corresponding error condition in an error register X'10' and X'11'.
 - Interrupts the CSP microcode.
2. The CSP microcode
 - Stops the transmit and receive operations in process.
 - In case of transmit, puts the transmit data line at mark.
 - In case of receive, stops the receive command and modem monitoring.

DMA Bus Errors Reported by the FESH They are reported by the FESH through a level 2 interrupt and then both interface are disabled by the microcode. The CSP microcode fills the LCS field of the PSA status with a status byte telling the reason for the error (Refer to “Line Communication Status (LCS)” on page 5-31 and “Extended Line Communication Status (ELCS) (Initial Status=B'110') for HSS” on page 5-35 for code description).

The microcode then raises CCU level 2 interrupt.

Line interfaces are started again by the CSP microcode when the NCP sends the proper SDLC command sequence.

CSP Interconnection Errors

The CSP communicates with the FESH through the external registers located in the FESH (register range X'0D' to X'17').

The FESH completes the operation with the 'acknowledge' signal to the CSP if no error conditions were detected.

The FESH monitors the CSP interconnection for the following errors:

- Interconnection error signal from the CSP
- Bidirectional cycle steal data bus parity error
- External register address and select out parity error
- Data out odd parity error during an external register write operation.
- External register address invalid.

If an error occurs in the external register address because of a parity error or because the external register does not exist in the FESH, the 'acknowledge' signal is not sent to the CSP.

Also, if the data bus parity is incorrect during an external register write, the 'acknowledge' signal is not sent to the CSP.

When 'acknowledge' is not returned to the CSP by the FESH, the CSP sets the adapter interconnection check bit ON (external register X'03' bit 6 = 1) and terminates the operation.

The FESH does not report any error condition.

Parity errors occurring on the cycle steal interconnection can be detected by the FESH or by the CSP.

If the FESH detects a parity error on the data bus during a cycle steal write, the FESH sets a level 2 interrupt to the CSP with the CSP interconnection error bit ON (external register X'10' bit 3=1) after completing the operation.

The parity checking on the cycle steal address bus and the CSP data bus during a cycle steal or external register read operation is performed by the CSP.

When the CSP detects a parity error, the CSP sets the adapter interconnection check in CSP register X'03' and activates the 'cycle steal error' line.

When the FESH detects this signal, the cycle steal operation ceases and the FESH activates a level 2 interrupt to the CSP.

The CSP interconnection error bit is set ON in FESH external register X'10'.

Detection of this error causes a level 2 interrupt to the CSP.

If an NCP transmit or receive operation is in progress, it continues until the CSP microcode stops reception of data for the receive command, or stops transmission of data and sets the transmission line to mark.

FESH Internal Checkers

Data Parity Checkers All the microcode (DMA layer, CSP layer, bit-layer, byte-layer) and data are checked for parity when the FESH internal buffers are read or written.

NCP Buffer Handling Logic Checker In order to check that the hardware logic which calculates the NCP buffer data area address from the NCP buffer prefix is working properly, the transmit and receive byte layer microcodes perform a predetermined calculation during inactivity periods. If there is a mismatch between the result of the calculation and the predetermined result, the FESH hardware reports an internal error condition.

Reporting When any of the above checkers becomes active:

- The FESH:
 - Stores the corresponding error condition in an error register.
 - Interrupts the CSP microcode at level 0.
- The CSP microcode:
 - Stops the transmit and receive operations in process.
 - In case of transmit, puts the transmit data line at mark.
 - In case of receive, stops the phase monitor.

Line Interface Check

A driver check function is implemented on the line interfaces of the FESH (V.35 / X.21).

When a driver check is detected, the hardware:

- Sets the driver check bit in the transmission status register.
- Interrupts the CSP.

No other action (no line interface disabling) is taken by the hardware.

Error Status

Error Status Byte 0

Bit	Type 1	Type 2	Type 3
x... ..	R/W (IOH)	R/W (AIO)	Always ON
.x.. ..	I/O bus check	I/O bus check	Invalid lev.0 interr.
..x. ..	Not used	Cycle steal grant	Invalid lev.1 interr.
...x ..	I/O bus tag I/O	I/O bus tag I/O	Invalid lev.2 interr.
.... x...	Halt	Halt	Microcode check
.... .x..	TA	Not used	CS/CCU L2 stack overf.
.... ..x.	TD	TD	Reject: command on cmd
.... ...x	Not used	Not used	Disconnect state

Error Status Byte 1

Bit	Type 1	Type 2	Type 3
x...	TA select	Not used	Command reject
.x..	Not used	Cycle steal select	Invalid output IOH type
..x.	Not used	Not used	<div style="display: flex; align-items: center;"> <div style="border-left: 1px solid black; border-right: 1px solid black; height: 100%; margin-right: 5px;"></div> <div style="margin-left: 5px;"> <p>See note below</p> </div> </div>
...x	Not used	Line interface address bit 0	
.... x...	Not used	Line interface address bit 1	
.... .x..	Not used	Line interface address bit 2	
.... ..x.	Not used	Line interface address bit 3	
.... ...x	Invalid input IOH	Line interface address bit 4	Adapter interconn. check
.... ...x			

Note: Next comes the decoding of bits 0 to 7 when command reject occurs.

Bit	Normal Command Reject	Trace Command Reject	Invalid Output IOH
x... ..	Command reject	Command reject	Always OFF
.x... ..	Always OFF	Always ON	Invalid output IOH
..x.	} Line interface address (0 to 3F)	Not used	} Line interface address (0 to 1F)
...x		Not used	
.... x...		} Slot number (0 to F)	
.... .x..			
.... ..x.			
.... ...x			

Four types of error may be reported:

- Type 1** Error detected by the CCU during PIO. A halt is send to the CSP, which results in a CCU or MOSS level 1 interrupt.
- Type 2** Error detected by the CCU during AIO. A halt is send to the CSP, which results in a CCU or MOSS level 1 interrupt.
- Type 3** Internal logical errors detected by the CSP microcode. A CCU level 1 or MOSS level 4 interrupt is set.
- Hard Stop** A CSP microprocessor check has been encountered. The CSP hardware responds with the error status.

The following tables shows the detailed responses that may be presented to a get error status command:

Hard Stop Error Status (Detected by CSP Hardware)

Byte 0

Bit	Meaning
* * * * *	Not used
. x . .	Control store data check
. x .	LSR or external register parity check
. x	Internal check
	} Only if processor check

Byte 1

Bit	Meaning
x	Unexpected adapter acknowledgment
. x	Control store write data check
. . x	Processor check
. . . x	External register address check
. . . . x	Control store address check
. x . . .	LSR address check
. * *	Not used

Miscellaneous Status Fields

Three status fields, the status control field (SCF), the secondary status field (SES), and the line communication status field (LCS), have so many different meanings, dependant on the type of line control used, that they are grouped here for easy reference.

Status Control Field (SCF) Bit Definition

The bits of the SCF byte describe the progress of the operation being executed.

Bit	Meaning
x	Halt/abort
. x	Service request
. . x	Scanner underrun/overrun
. . . x	Modem check
. . . . x	Data stored
. x . . .	End of message (EOM)
. x . .	Data transmitted occurred
. x	Receive sequence

Secondary Status Field (SES) Bit Definition

The bits of the SES byte identify errors encountered during the execution of the command. When any bit is ON in this byte, the service request bit (bit 1) in the SCF must be OFF, except for 'modem retrain' in NCP BSC.

Bit	Meaning
x	Modem retrain
. x	Idle detection (SDLC) or format exception (NCP BSC, EP BSC)
. . x	LPDA reply received, but TI failed to come up /transient error
. . . x	Data check (SDLC, NCP BSC, EP BSC)
. . . . x	Flag off boundary (SDLC) or bad PAD (NCP BSC)
. x . . .	In phase (EP BSC)/TI ON (NCP BSC & SDLC)
. x . .	DLE error (NCP BSC)
. x	Early flag (SDLC)/length check (NCP BSC)

Line Communication Status (LCS)

The bits of the LCS byte contain statuses applicable to the line being serviced. The byte is divided into three fields as shown below:

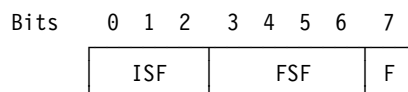

ISF = Initial status field
 FSF = Final status field
 F = Leading graphics / timeout during X.21 clear

The indicator field (bit 7) specifies whether or not, leading graphics were the first characters received.

Initial Status Field (ISF) Bit Definition

The ISF (LCS bits 0 - 1) indicates essentially the type of line control that is used. The ISF is decoded as follow:

NCP BSC Receive Only: See paragraphe "Initial Status = B'0xx'" on page 5-33 for more explanation.

ISF	FSF	F	
0 1 2	3 4 5 6	7	Meaning
0 0 0	Control mode, no text received (receive only)
0 0 1	Text mode , STX is first character
0 1 0	Transparent text mode, DLE STX are first char
0 1 1	Header mode, SOH is first character

Special: See paragraphe "Initial Status = B'100' (Special)" on page 5-33 for more explanation.

ISF	FSF	F	
0 1 2	3 4 5 6	7	Meaning
1 0 0	Special status

Errors: See paragraphe "Initial Status = B'110' (Internal Box Error)" on page 5-34 and paragraphe "Initial Status = B'111' (Hardware Error)" on page 5-36 for more explanation.

ISF	FSF	F	
0 1 2	3 4 5 6	7	Meaning
1 1 0	Internal box error
1 1 1	Hardware error

Final Status Field (FSF)

The FSF (LCS bits 3 - 6) gives further status information. The encoding is based upon the ISF configuration and is defined as follows:

Initial Status = B'0xx'

ISF	FSF	F	Meaning
0 1 2	3 4 5 6	7	
0 x x	0 0 0 0	x	Timeout occurred after reception has begun and ISF is not 000
0 x x	0 0 1 1	x	ENQ received
0 x x	0 1 0 0	x	EOT received
0 x x	0 1 0 1	x	DLE/xxx was received (xxx=any valid second character)
0 x x	0 1 1 0	x	Wrong ACK received
0 x x	0 1 1 1	x	NAK received
0 x x	1 0 0 1	x	ETX received
0 x x	1 0 1 0	x	ETB received
0 x x	1 1 0 1	x	RVI received
0 x x	1 1 1 0	x	Positive ACK (0 or 1) received
0 x x	1 1 1 1	x	WACK received

Initial Status = B'100' (Special)

ISF	FSF	F	Meaning
0 1 2	3 4 5 6	7	
1 0 0	0 0 0 0	x	Timeout (nothing received); ACR, COS, DLO, or PND failed to drop; X.21 timeout on ready for data
1 0 0	0 0 0 1	x	Ending condition on start/stop
1 0 0	0 0 1 0	x	X.21 timeout during clear
1 0 0	0 0 1 1	x	386x/58xx test control active/X.21 timeout on proceed to select
1 0 0	0 1 0 0	x	DLE-EOT disconnect sequence received
1 0 0	0 1 0 1	x	Lost data
1 0 0	0 1 1 0	x	Poll entry too long
1 0 0	1 1 0 0	x	EOT transmitted
1 0 0	1 1 0 1	x	X.21 call progress signal (CPS) error
1 0 0	1 1 1 0	x	Disconnected/X.21 DCE clear received
1 0 0	1 1 1 1	x	Connected

Notes:

1. When a special status occurs, the line is set to the disable state.
2. For X.21, if 'DTE clear' or 'DCE clear' confirmation is required, the 'X.21 timeout during clear' flag (bit 7) is added to the final status to indicate the result of the clear operation. Bit 7 is set to zero if the clear was successful, and to one if it was not.

Initial Status = B'110' (Internal Box Error)

ISF	FSF	F	
0 1 2	3 4 5 6	7	Meaning
1 1 0	0 0 0 0	x	AIO error
1 1 0	0 0 0 1	x	Adapter check
1 1 0	0 0 1 0	x	Scanner interconnection error
1 1 0	0 0 1 1	x	Scanner failed to answer
1 1 0	0 1 0 0	x	Scanner internal error
1 1 0	0 1 0 1	x	Multiplex failure
1 1 0	0 1 1 0	x	Transient counter overflow
1 1 0	0 1 1 1	x	LIC / ICF error
1 1 0	1 0 0 0	x	No interrupt from scanner
1 1 0	1 0 0 1	x	Command rejected
1 1 0	1 0 1 0	x	Trace already active
1 1 0	1 0 1 1	x	Scanner error reporting path check
1 1 0	1 1 0 0	x	Invalid level 2 interrupt
1 1 0	1 1 0 1	x	Modem already in test mode
1 1 0	1 1 1 1	x	Line not accessible

Notes:

1. For NCP operations, the line is set to the disable state.
2. For NCP operations on duplex lines, the command on the failed interface is ended; the LCS indicates the cause of the error, and a level 2 interrupt is raised to the CCU. The command on the other interface is cleared; no ending status is set, and no interrupt is raised to the CCU.
3. For EP operations, the line is set to the NO-OP state.
4. After hardware error, the only commands accepted for that line is 'enable', 'monitor incoming call', or 'dial' (if autocal interface).

Initial Status = B'110' (Internal Box Error HSS): The code is the value of the LCS bits 0 to 7 (fields ISF, FSF, F).

Code Description

- C0** AIO error indicates a hardware error during an adapter-initiated operation (cycle-steal).
- C2** Adapter interconnection check indicates a FESH hardware error.
- C4** CSP interconnection error indicates a CSP/FESH interconnection hardware error.
- C6** FESH failed to answer to a microprogram-initiated operation.
- C8** FESH internal error indicates hardware error in the FESH detected by the FESH itself.
- CE** Local attach clock failure (F5 only).
This is returned as an F5 command status if the local attach clock has failed while in use.
- D0** No interrupt from FESH indicates that the FESH has failed to respond to a microcode request.
- D2** Command rejected indicates that the command issued by the control program has been rejected by the CSP.
- D4** Trace already active indicates that the SIT is already running on this interface.
- D8** Invalid FESH level 2 interrupt indicates that an unexpected CSP level 2 interrupt from the FESH has occurred.
- DC** ELCS is valid.
- DE** Line not accessible indicates that one of the two possible lines is already active and a set mode is received for the other line.

Extended Line Communication Status (ELCS) (Initial Status=B'110') for HSS: When the LCS = X'DC', additional statuses, as on internal box errors, may be found in byte 4 of the status area. These additional statuses are:

Code Description

- 02 (a)** SCTL/DMA internal error
- 04 (e)** SCTL/DMA interconnection error
- 06** Combination of (f) and (g)
- 08 (3)** DMA time out on write
- 0A (1)** DMA interconnection error in write
- 10 (c)** SCTL/DMA storage protect/address exception
- 12 (b)** SCTL/DMA logical error
- 14 (f)** DMSW main bus parity check
- 16** Combination of (f) and (h)
- 18 (4)** DMA time out on read
- 1A (2)** DMA interconnection error on read
- 22 (d)** Storage unrecoverable error/SCTL internal error
- 24** Combination of (e) and (f)
- 28 (g)** DMSW parity check on primary/secondary bus
- 2A (5)** DMA bus driver fault
- 34** Combination of (e), (f) and (g)
- 3A (6)** DMA burst count error
- 44** Combination of (2), (e), (f) and (g)
- 4A (h)** DMSW driver fault
- 5A** Combination of (1), (e), (f), and (g)
- 6A** Combination of (2) and (g)
- 7A** Combination of (2) and (h)
- 9A** Combination of (5), (e), (f) and (g)
- AA** Combination of (6) with any of (a) through (h)
- BA** Combination of (1) through (6) with any of (a) through (h) which are not listed above.

Initial Status = B'111' (Hardware Error): Detailed descriptions of hardware errors:

ISF	FSF	F	Meaning
0 1 2	3 4 5 6	7	
1 1 1	0 0 0 1	x	CTS dropped during command/modem retrain
1 1 1	0 0 1 1	x	RLSD failed to drop on disable command (not used by NCP)
1 1 1	0 1 1 1	x	DSR dropped during command/ external clock error (F5)
1 1 1	1 0 0 1	x	TI/CTS failed to come up
1 1 1	1 0 1 0	x	DSR failed to come up
1 1 1	1 0 1 1	x	No cable installed or wrong cable
1 1 1	1 1 0 0	x	TI/DSR and/or CTS failed to drop (on disable and transmit data commands on half-duplex lines without duplex facilities
1 1 1	1 1 0 1	x	X.21 disconnected DCE clear receive, with or without timeout
1 1 1	1 1 1 0	x	Autocall check

Notes:

1. For NCP operations, the line is set to the disable state.
2. For NCP operations on duplex lines, the command on the failed interface is ended; the LCS indicates the cause of the error, and a level 2 interrupt is raised to the CCU. The command on the other interface is cleared; no ending status is set, and no interrupt is raised to the CCU.
3. For EP operations, the line is set to the NO-OP state.
4. After hardware error, the only commands accepted for that line is 'enable', 'monitor incoming call', or 'dial' (if autocall interface).

Initial Status = B'111' (Hardware Error HSS): The code is the value of the LCS bits 0 to 7 (fields ISF, FSF, F).

Code Description

- E2** CTS dropped indicates clear to send failed during transmission.
- EE** V.35 DSR dropped/X.21 DCE not ready, or external clock failure indicates that DSR failed for V.35 connection, or that the DCE is not ready for an X.21 connection in response to an F5 command.
- F2** CTS failed to come up. Clear to send did not rise after request to send was set.
- F4** DSR failed to come up. Data set ready did not rise after data terminal ready was set.
- F6** No cable installed. There is no cable connected to the modem.
- F8** DSR/CTS failed to drop on a disable. On a disable command, data set ready or clear to send did not drop.
- FA** X21 DCE not ready. An X.21 DCE not ready state was detected.

Note: In all cases of internal box errors and hardware errors, the line is disabled by the CSP. The command on the failed interface is ended (LCS contains the error and a level 2 interrupt request is raised to the CCU).

The command on the other interface is cleared without any ending status or level 2 interrupt request to the CCU.

After such an error the only commands that are accepted on the line are 'set mode' or 'enable'.

Diagnostic Facilities

Refer to the *3745 Diagnostic Descriptions* manual, SY33-2059, for more details.

Problem Determination Aid

The following tools are provided to help define which area is failing:

1. Scanner interface trace (SIT) and checkpoint trace
2. Line interface display (LID).
3. LSS functions from the MOSS service menu (Refer to the *Service Functions* manual, SY33-2069).

Microcode Service Aid The FESH registers, the microcode RAM locations and the external data control RAM locations can be accessed, using the following facilities (Refer to the *Service Functions* manual, SY33-2069, and *Advanced Operations Guide* manual, SA33-0097):

1. Alter/display
2. CSP address compare
3. CSP dumps.

These facilities, invoked from the operator console, help in analyzing/modifying the contents of the HSS storage and registers (CSP and FESH).

Programming Support for Problem Determination It includes, as for LSS microcode:

1. Error detection
2. Error collection
3. Error reporting.

Types of error tracked are:

- CSP/IOC bus interconnection errors
- CSP internal errors
- CSP/FESH interconnection errors
- DMA/SCTL errors
- FESH errors
- FESH-to-line interface errors.

NCP Buffer Prefix Validity Checking in Receive

This test is performed by the microcode for the first buffer only, by using the parameters coming from the PSA.

Problem Isolation and Network Management

External Wrap Facility

After a power-ON reset, the interface defaults to the 245.76 kbps clock speed if the cable ID bits specify local attach.

The interface is neither selected nor enabled after a power-ON reset.

A different clock selection can be made by the NCP at set mode time with indirect register X'11'.

The FESH also provides an external interface wrap facility by inserting a wrap plug at the tail gate connection. Commands initiating the wrap are sent from the MOSS console.

Notes:

1. The wrap plugs are described in the *External Cable References* manual, SY33-2075.
2. The procedure to perform a wrap test at the tail gate, using a wrap plug, is described in the *IBM Maintenance Information Procedures (MIP)*.

The cable ID bits are changed by the wrap plug. The X.21 or V.35 signals are wrapped as specified by the interface ID bit (indirect register X'06' bit 1) and the clock defaulted to the clock speed selected by the NCP at set mode during a wrap.

The external clock is under microcode control as specified by external register X'11'.

Wrap Mode at DCE Level The wrap is started from the MOSS console.: The diagnostics can perform a wrap function from the transmit to the receive interface on the logic side of the line drivers/receivers, at a speed of 1.966 Mbps or at a speed controlled by the diagnostics.

The following figure illustrates the problem determination and testing configuration for V.35/X.21 network attachment.

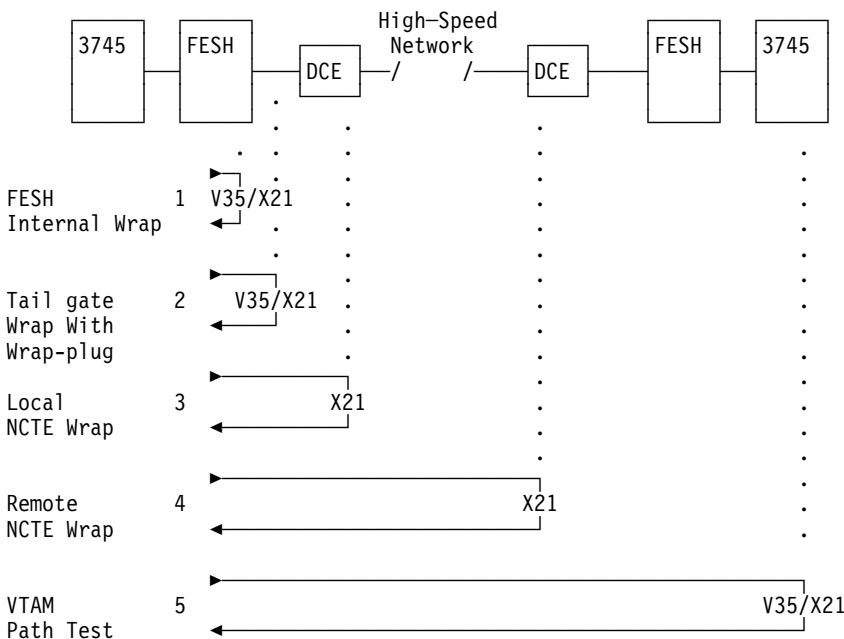

Note: Test is also available from the right hand side.

Figure 5-7. V.35/X.21 Configuration Showing Wrap Tests or Loop Tests 1 to 5

Manual V.35/X.21 Wrap or Loop Tests The manual wrap or loop tests are initiated from the MOSS console.
(Loop test 3 and 4 are for X.21 only).

Internal Wrap	Or Loop Test 1 checks the ability of the HSS to transmit and receive, up to the output of the FESH card.
Tail Gate Wrap	Or Loop Test 2 in addition to loop test 1 checks the cables between the FESH card and the tail gate. A wrap plug is required.
Local NCTE Wrap Test	Or Loop Test 3 checks the transmit and receive ability of the 3745, up to the first network communication terminal equipment (NCTE).
Remote NCTE Wrap Test	Or Loop Test 4 checks the transmit and receive ability of the 3745, up to the second NCTE and including the communication media.
VTAM Path Test	Or Loop Test 5 checks the transmit and receive ability of the two controllers.

Communication Interfaces

The HSS interfaces external high-speed data links to either the 3745 or the 3725:

- Remotely via DCE attachment
- Locally via direct attachment to another HSS or LIC type 3/4 on the 3725.

The physical and logical interfaces are either:

- CCITT V.35 or,
- CCITT X.21 leased (including French Transfix).

The high-speed data links access the HSS directly through the FESH via the tail gate without a LIC card.

FESH-DCE Interface

The FESH is physically able to support two interfaces. However, only one interface can be active and communicating, while the other interface is disabled.

The NCP controls the enabling and disabling of each interface.

On reception of the line address activation from the NCP, the microcode sets the corresponding bit in the FESH to select the proper port.

To determine which interface was selected by the hardware (V.35 or X.21) on the selected port, the microcode reads the cable ID in the FESH.

The FESH is also capable of supporting different electrical interfaces.

Each of the two physical interfaces can independently support the following interfaces to the network communication terminal equipment (NCTE):

V.35
X.21

Any combination of physical interfaces are supported. The physical interface is identified by cable ID signals in the cable. The following combinations are possible:

- Two V.35 interfaces
- Two X.21 interfaces
- One V.35 and one X.21 interface

NOTE: Before unplugging the cable from the tail gate or DCE, ensure that the line is not active by disabling the interface, using VTAM commands.

Failure to perform this step can cause an FESH adapter check.

Two V.35 Cables Connected (Example)

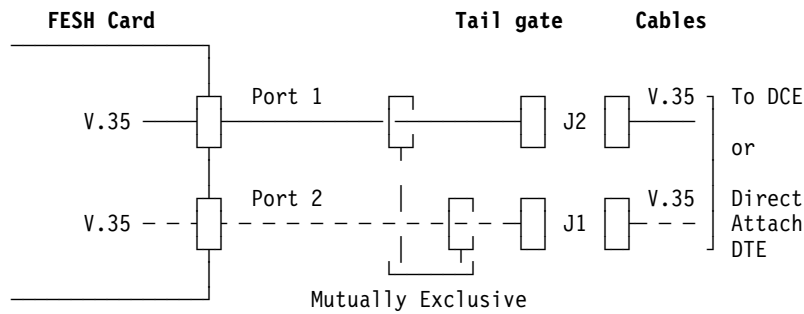

Two X.21 Cables Connected (Example)

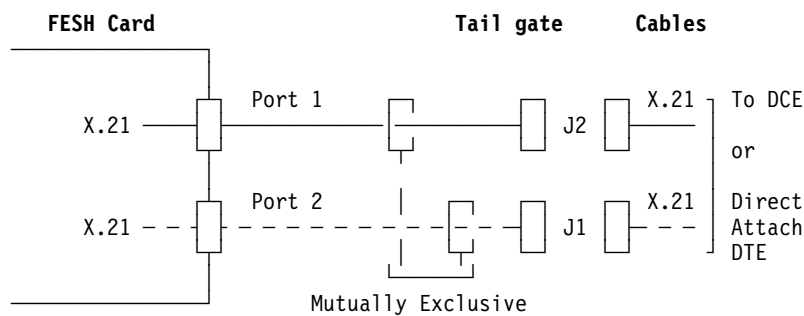

One V.35 and One X.21 Cables Connected (Example)

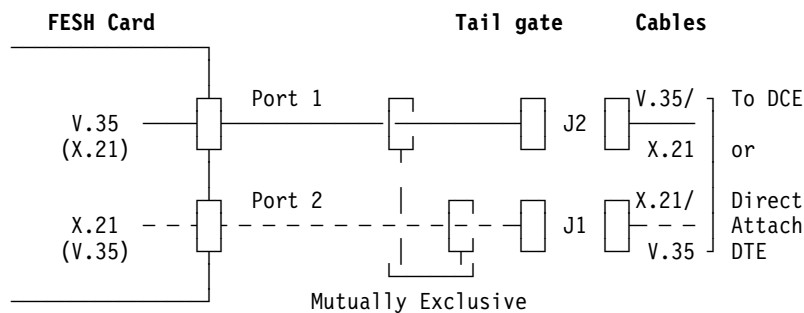

The FESH supports the CCITT standard V.35 interface. All interface signals conform to the electrical specifications as stated in the various CCITT standards.

X.21 Interface The HSS supports the 1987 CCITT X.21 standard for transmitting data at speeds up to 2.048 Mbps.

Cable Diagrams

DCE interface signals exit the FESH using two top card connectors, one for interface 1 and one for interface 2.

Each interface cable contains the V.35, X.21, and cable ID signals to the 3745 tail gate.

All balanced signals use twisted pairs from the tail gate to top card connector.

Unbalanced signals use a twisted pair of wires with one signal wire and one ground wire to eliminate any noise problems.

The **external cable** attached to the tail gate determines the physical interface supported, using the cable ID bits and the V.35 or X.21 identifier.

The FESH hardware gates the appropriate drivers and receivers to the network adapters.

Cable Length Limitations For cable length limitations, refer to *External Cable References*, SY33-2075.

Clocking

Because of the high transmission speeds and propagation delays in the cable, the transmit clock received from the DCE or NCTE is re-driven and sent to the DCE or NCTE in synchronization with the data.

Local Attachment

The HSS supports direct attachment (no DCE) with another HSS using the X.21 or V.35 interface.

When directly connected together, one FESH is designated as local attach by the cable ID bits and automatically provides the receive clock to the other FESH.

The other FESH attaches in DCE mode with the external clock supplied by the local attach HSS. Three attachment speeds are offered as specified in indirect register X'11'.

1. 1.8432 Mbps
2. 1.47456 Mbps
3. 245.76 kbps

Chapter 6. The Token-Ring Subsystem

The TRSS in 3745 Models 130, 150, 160, and 170 Data Flow	6-2
The TRSS in 3745 Model 17A Data Flow	6-3
Token-Ring Network	6-4
IBM Token-Ring Network	6-4
Cabling System (Ring)	6-5
Token-Ring Adapter	6-5
Access Protocol	6-7
Major System Components	6-7
The Token-Ring Adapter in the 3745	6-10
Introduction	6-10
Packaging	6-10
Token-Ring Interface Coupler (TIC) Card	6-12
TIC Data Flow	6-12
The Front End	6-13
The Protocol Handler	6-13
The Message Processor	6-13
TIC Bus Interconnection Control	6-14
Receive Operation	6-14
Transmit Operation	6-15
Token-Ring Multiplexor (TRM) Card	6-15
IOC Bus Interconnection	6-16
Summary of the IOC Bus Interface Signal Lines	6-17
TIC Bus Interconnection	6-17
Summary of the TIC Bus Signal Lines	6-18
TRM Arbitration Mechanism	6-18
TRA Resets	6-19
Power ON Reset and Tag Reset	6-19
Programmed Reset	6-19
TIC Reset	6-19
Diagnostic Section TAOA	6-19
Error Detection and Reporting	6-20
TRM Level 1 Error Status Register	6-20
TRM Level 2 Error Status Registers	6-22
MOSS Error Status Register	6-24
TIC Adapter Check Register	6-24
Problem Determination Aid	6-27
Token-Ring Wrap Tests	6-27

The TRSS in 3745 Models 130, 150, 160, and 170 Data Flow

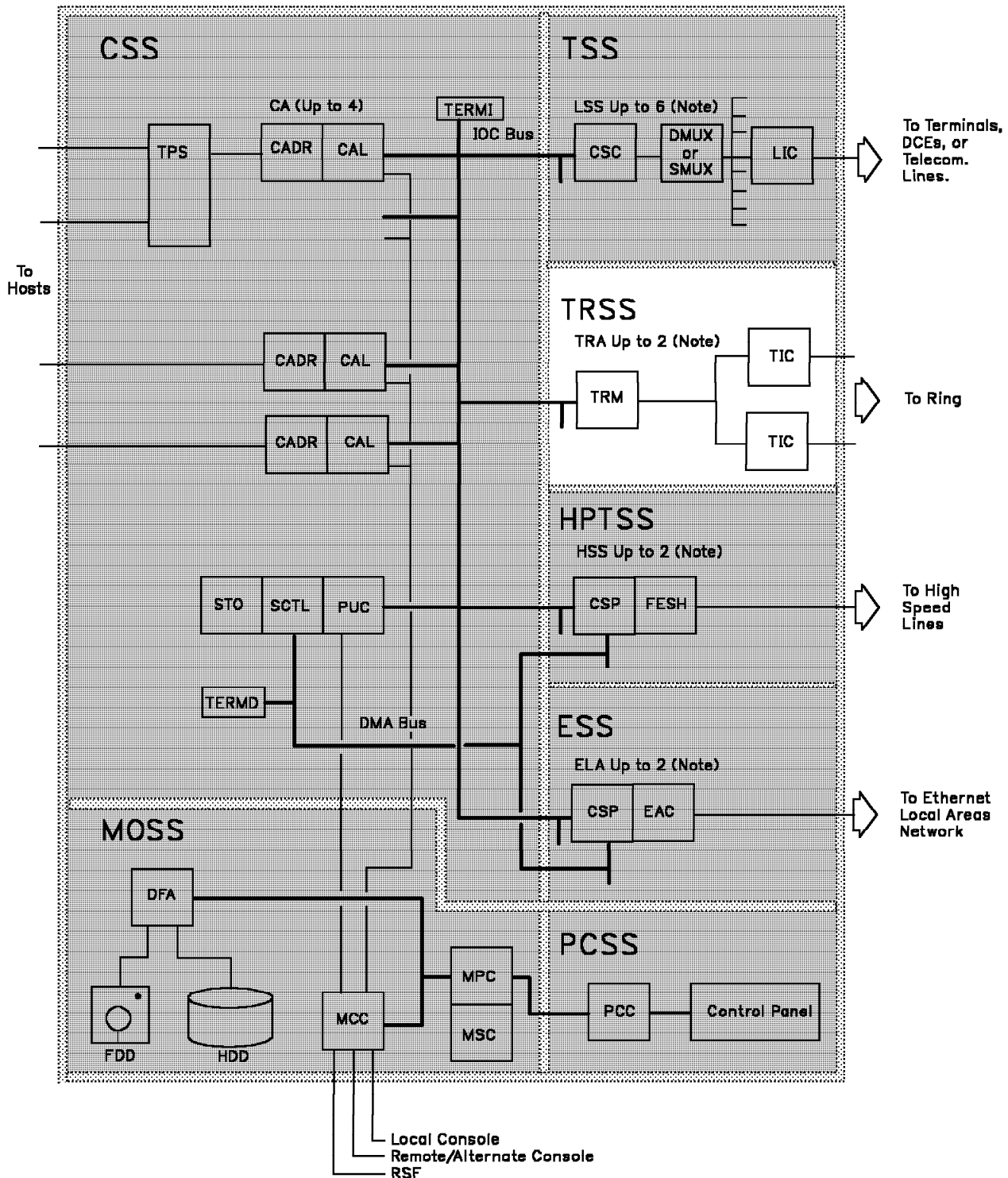

(Note) The number of LSS+HSS+ELA does not exceed 6

The TRSS in 3745 Model 17A Data Flow

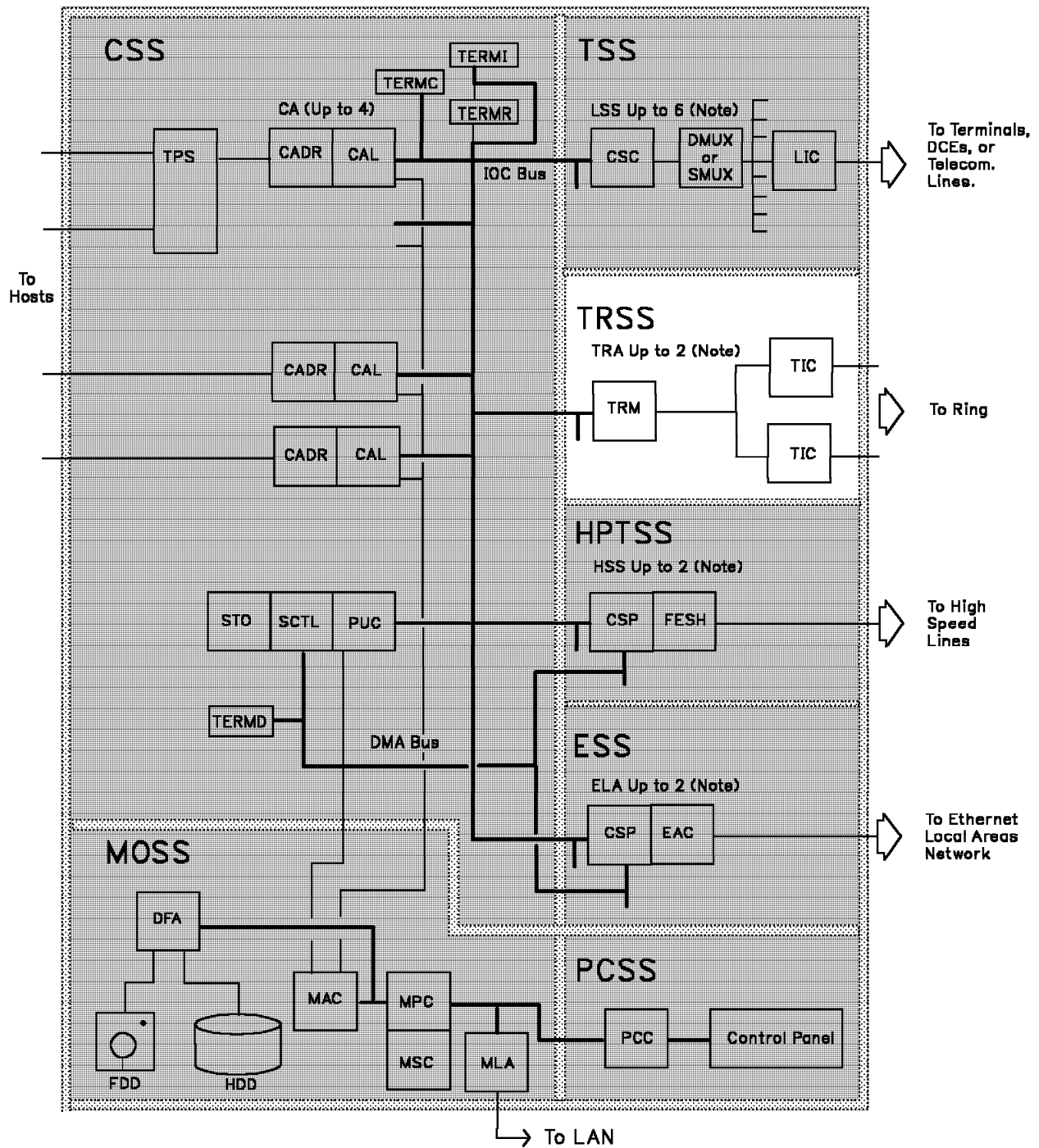

(Note) The number of LSS+HSS+ELA does not exceed 6

Figure 6-1. The TRSS in 3745 Model 17A Data Flow. For model 17A, DMA and IOC buses are connected to the CBC in the 3746-900. This MLA card links the MOSS to the Service Processor through a LAN.

Token-Ring Network

The token-ring networks are designed specifically to provide an integrated approach to communications in a particular location.

In case of large companies with multiple, widely separated sites, individual token-ring networks will almost always be interconnected.

In a token-ring network the data rate is much higher than is possible using common carrier communications.

A token-ring network can replace switched and non-switched telephone lines and also allow voice communications over the same cabling system that carries data communications.

The token-ring complies with the recommendation 802.5 of IEEE and the ISO 8802/5.

IBM Token-Ring Network

It is an information transport system that provides high-speed (4 Mbps or 16 Mbps) connection between users within a single building complex through the implementation of a common:

- Cabling system
- Communication adapter
- Access protocol

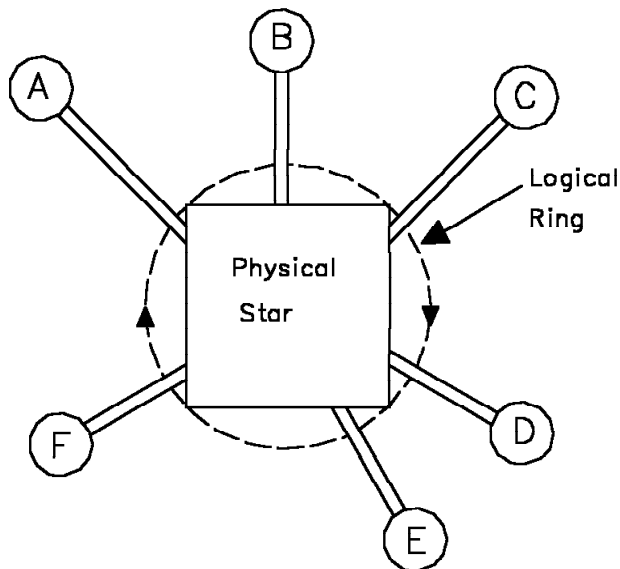

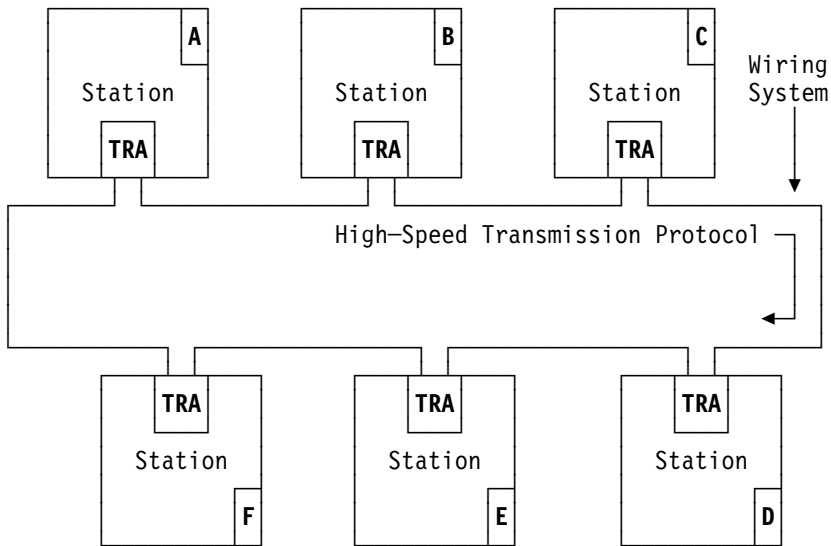

Legend: TRA : Token-ring adapter
 Station : Can be controller, display/keyboard terminal, node...

Figure 6-2. Token-Ring network Configuration Example

Cabling System (Ring)

Several transmission media may be used together:

- IBM Cabling System (twisted-pair of copper wire)
- Telephone communication facilities
- Optical fiber.

Token-Ring Adapter

The adapter in the 3745 has the following functions:

- Frame and address recognition
- Token generation
- Error checking and logging
- Buffering (transmit and receive)
- Time out controls
- Connect the product to the token-ring network.

For Example

The 3745 is connected to the IBM Token-Ring network through the token-ring interface coupler card (TIC). A cable composed of two pairs of copper wires (transmit and receive pairs), connects the controller to the multistation access unit (MSAU) through a wall connector.

The cable running from the controller or a station to the MSAU, is called a lobe.

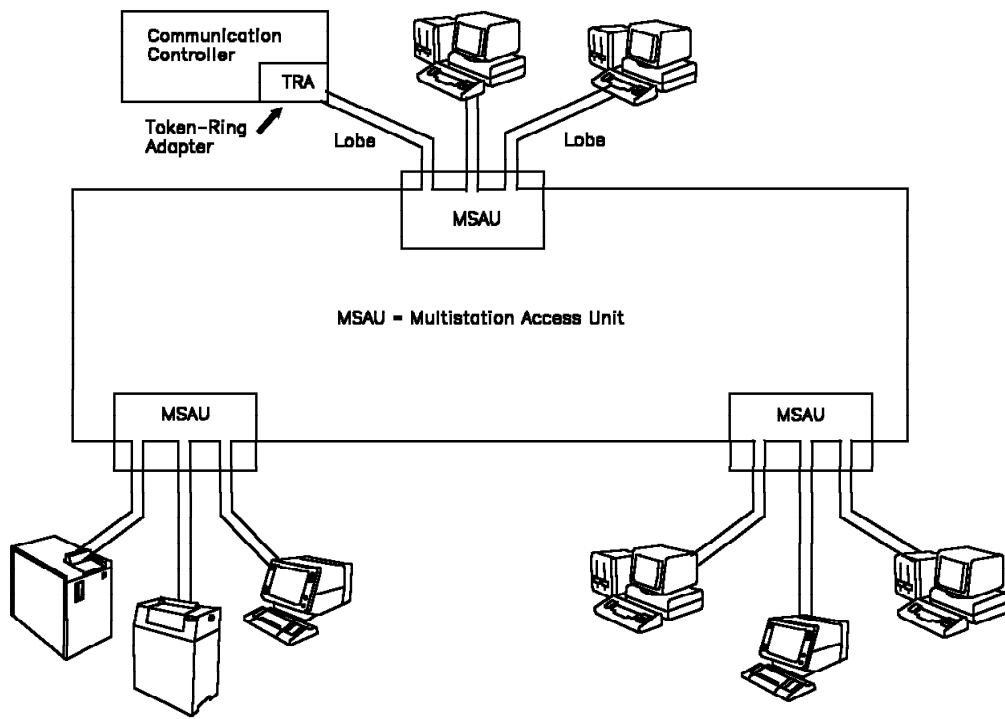

Figure 6-3. Example of Lobes

Multistation Access Unit The multistation access unit (MSAU) provides insertion service to the main ring for its attached lobes. Nodes or stations are attached to the lobes. The multistation access units that include electronic or electro-mechanical switching elements, are shown below:

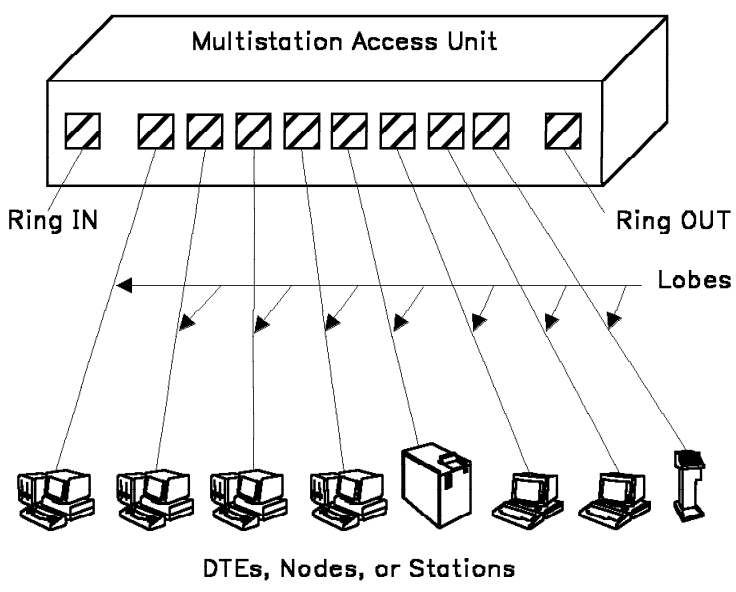

Figure 6-4. Multistation Access Unit

Access Protocol

A token is a short message. It travels around a communication ring that allows attaching different systems to the communications facilities provided by that ring. When a token is used for transmission by an attachment, it is known as a frame. Actually, a token is a very short frame (3 bytes) that has no addressing, message, or error-checking capabilities. Those are added when the token becomes a true frame.

General Frame Format

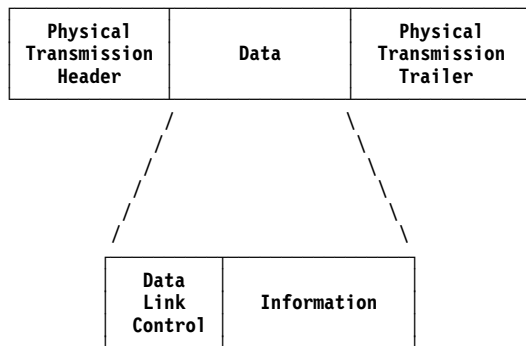

Figure 6-5. Frame Format

Once a station is physically attached to a ring, it first synchronizes itself to the data patterns passing through it over the ring.

Token-Ring Access Control Protocol

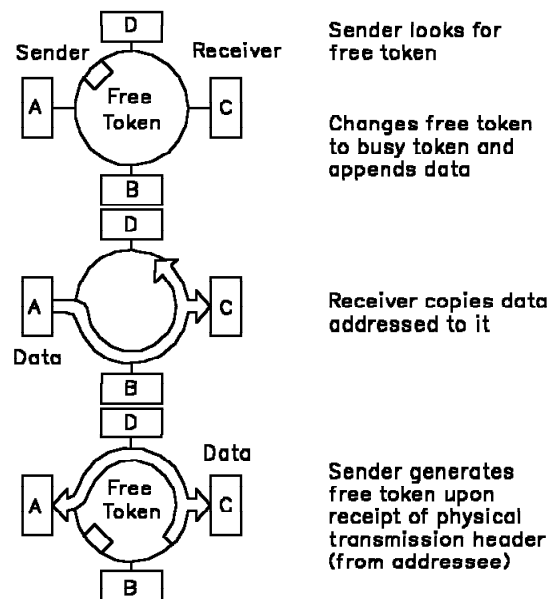

Figure 6-6. Token-Ring Access Protocol Example

Token-Ring Encoding The differential Manchester protocol is used as means to transmit information around the ring, to all devices connected to that ring and power-ON.

Major System Components

Nodes A node may be one of the following machines:

- Communication controller
- Intelligent workstation
- Keyboard/display terminal
- Printer
- Terminal control unit
- Processor
- Facsimile device
- Personal computer
- Protocol converter.

Interface Couplers Each node has its own token-ring interface coupler card to gain access to the token-ring network or ring.: The 3745 has up to eight token-ring interface coupler cards type 2 (TIC2) which can work at 4 or 16 Mbits.

Bridges A bridge is a high-speed switching device that allows linking multiple rings and maintaining a physical ring separation.

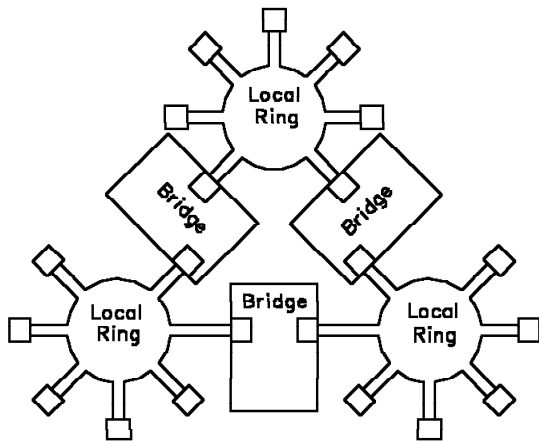

Figure 6-7. Ring-to-Ring via Bridge Example 1

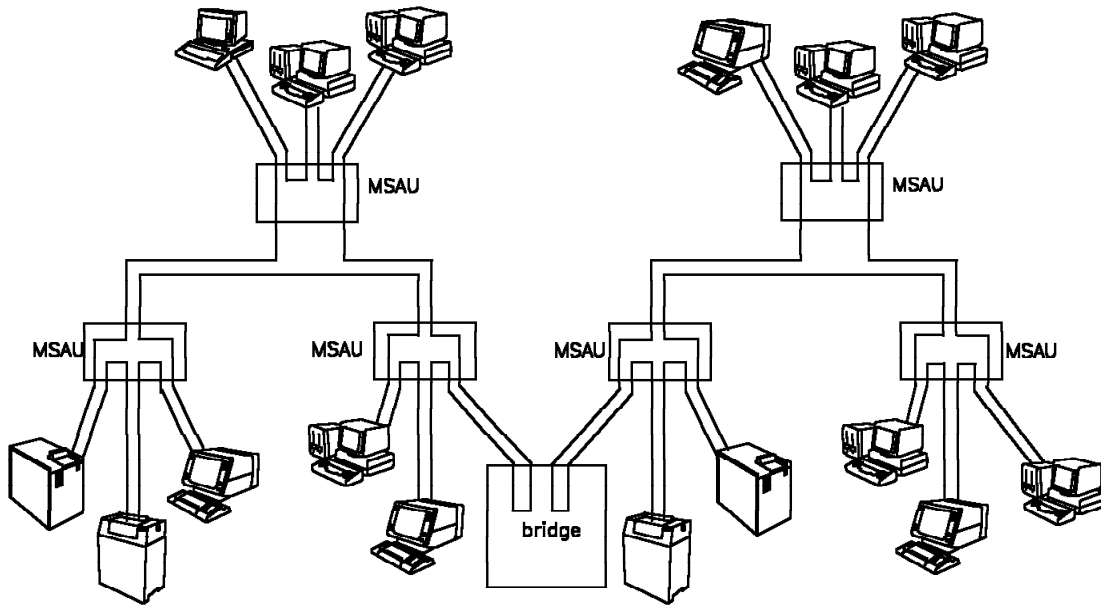
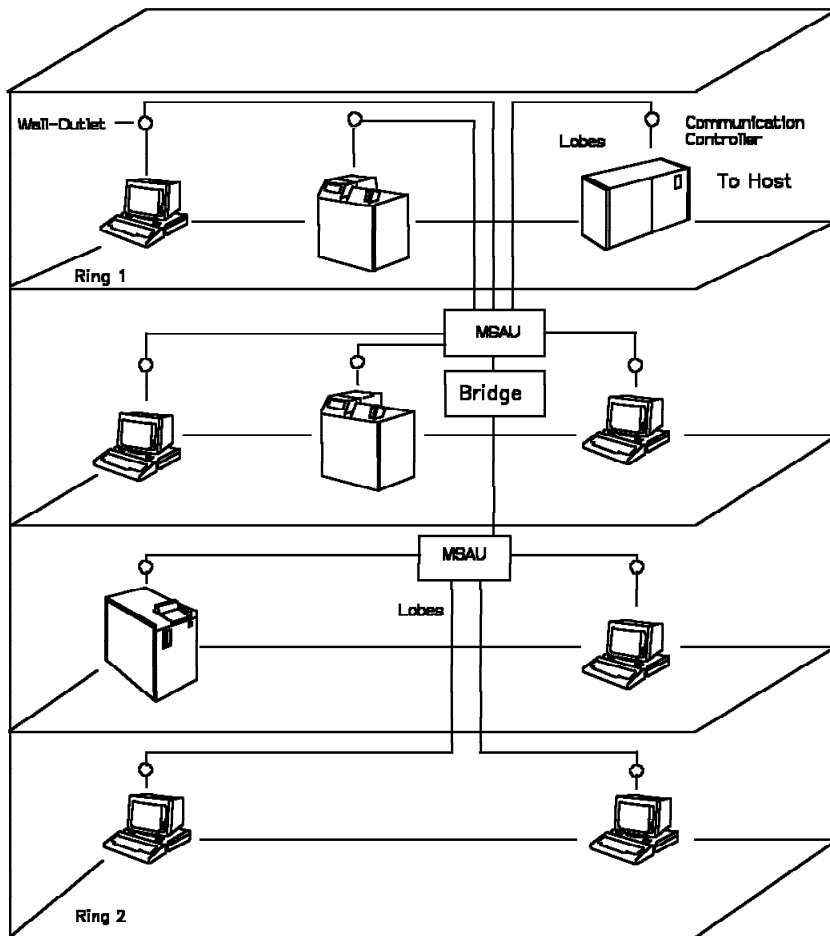

Figure 6-8. Ring-to-Ring via Bridge Example 2

Typical Multi-Floor Wiring



The Token-Ring Adapter in the 3745

Introduction

The token-ring subsystem (TRSS) allows connection to an IBM Token-Ring network which uses the token-ring protocol.

The TRSS in a communication controller is controlled by the NCP token-ring interconnection function.

The hardware is based on a processor-driven card named token-ring interface coupler card (TIC) and the token-ring multiplexer card (TRM). There are two types of TIC: TIC type 1 (TIC1) and TIC type 2 (TIC2). TIC1 runs at ring-speed of 4 Mbps only. TIC2 runs at a ring-speed of 4 Mbps or 16 Mbps (the speed is set through software).

The combination of a TRM and the associated TICs (up to two) is called a token-ring adapter (TRA). The TICs installed with a TRM must both be either TIC1's or TIC2's. A mixture of TIC types with the same TRM is not allowed. The combination of all the TRAs in a controller is called the TRSS.

One token-ring network can be accessed by each TIC card.

Packaging

Only one TRA may be installed on the basic board of the Models 00A and 00C and up to two TRAs in the Model 00B. Each TRA may control up to two token-rings. The TRM interconnects with the input/output control bus (IOC bus) and it is accessed from the CCU with a unique address as for the scanner. The two TIC cards are connected to the TRM by a bidirectional bus called the TIC bus.

For board and card locations, see the *Maintenance Information Procedures* manual, SY33-2070.

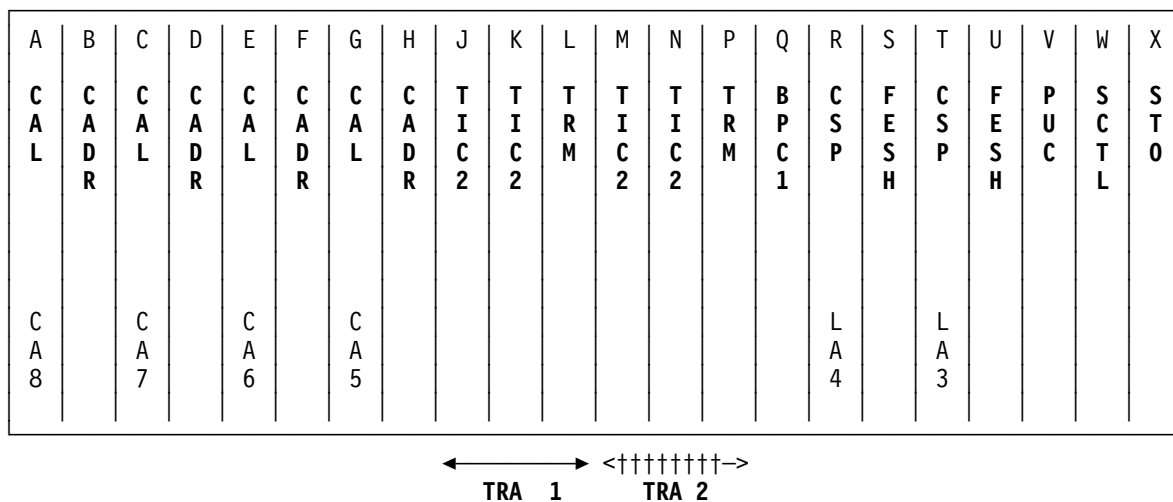

Figure 6-9. Basic Board Model 130

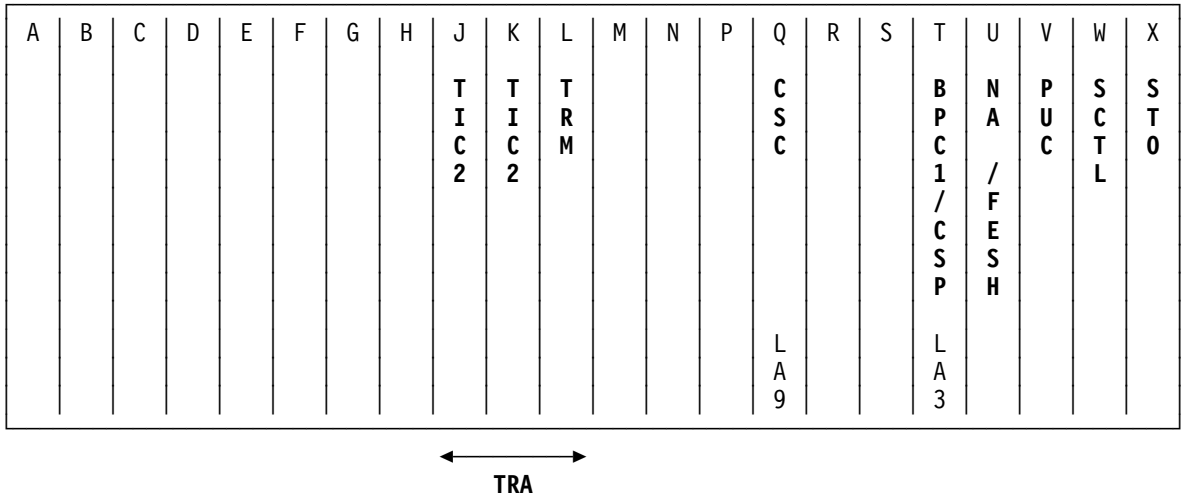

Figure 6-10. Basic Board Model 150

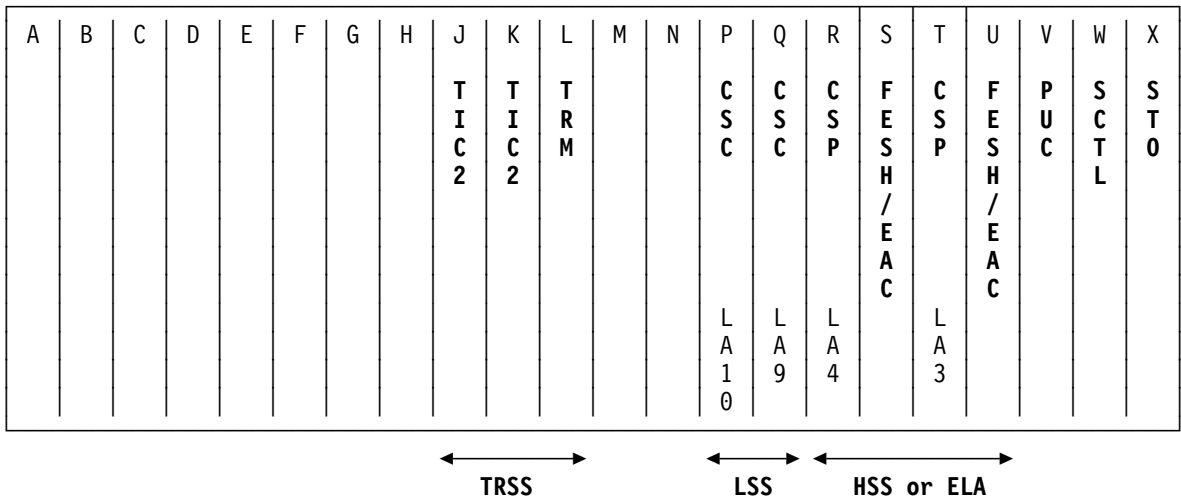

Figure 6-11. Basic Board Model 160

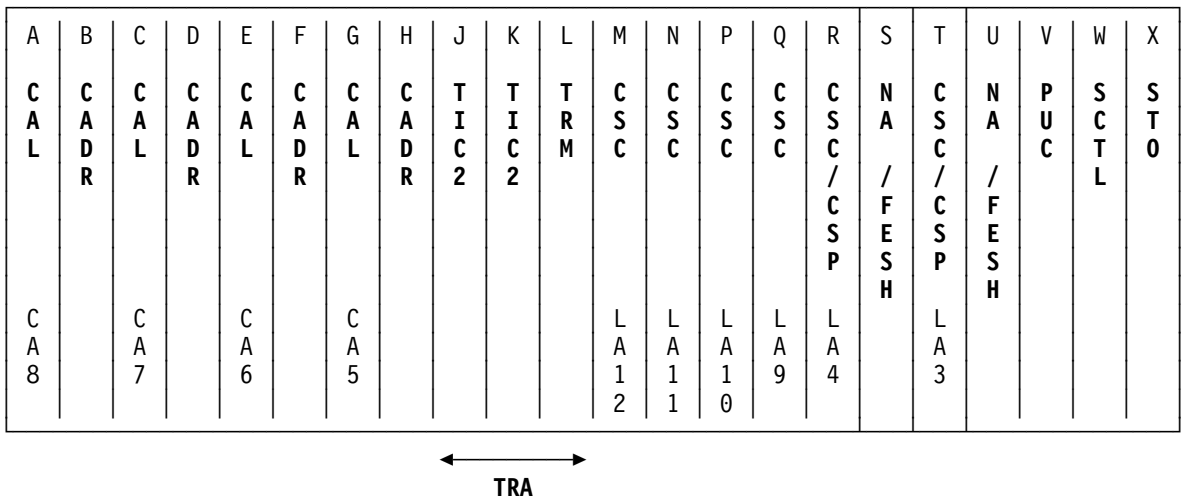

Figure 6-12. Basic Board Model 170

Token-Ring Interface Coupler (TIC) Card

The TIC card has a low profile connector for connection to the ring.

The card consists of four high-level functional areas.

- The front end that interfaces to the ring
- The protocol handler
- The message processor
- The TIC bus interconnection control.

TIC Data Flow

The TIC can perform the following operations on the data stream that passes through it on the ring:

1. Repeat the received data without copying it.
2. Repeat and copy the received data.
3. Change the state of single bits in the received data before retransmitting it.
4. Originate the transmission of data.
5. Remove from the ring messages that it has previously transmitted.

The next figure shows the relationship between the message processor and the other functional areas of the TIC card.

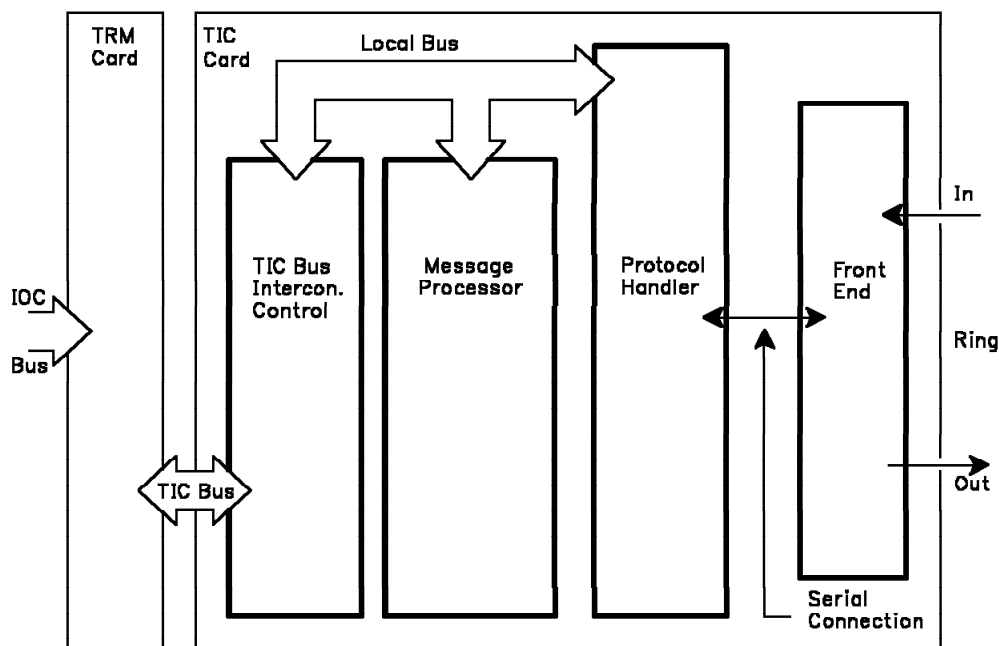

Figure 6-13. TIC Card Data Flow

The Front End

The front end is the direct interface with the transmission line of the ring.

The front end transmits and recovers Manchester-encoded data as it passes around the ring.

The front end synchronizes itself with the received data stream and develops a clock which is boundary-aligned to the bit stream.

The bit stream, along with the derived clock, is passed to the protocol handler.

The front end requires monitoring and control by the protocol handler.

The Protocol Handler

The protocol handler acts as the logical interconnection between the front end and the local bus.

It prepares received data for processing by the microcode operating in the microprocessor of the message processor.

It also prepares data that has been assembled by the microprocessor for transmission through the front end onto the ring.

It decodes addresses for recognizing received messages and strips messages from the ring that have been previously transmitted.

It checks that the ring is active and operational.

These logs are used to isolate the faulty element in the IBM Token-Ring network.

The protocol handler controls and maintains the low-level bit and byte protocols on the ring.

The Message Processor

The message processor acts as the master control element for the protocol handler and the TIC bus interconnection control in the TIC card. Interaction with these functional areas is across an 18-bit local bus. The message processor is the general name for the microprocessor (microcode and the hardware). It consists of the following items:

- A microprocessor
- Static random access modules (RAM) for message data
- Static random access modules (RAM) for parity
- Read-only storage modules (ROS) for microcode.

The microprocessor uses the random-access memory (RAM) as workspace when processing instructions.

The message processor can set up control conditions or interrogate status across the local bus using MMIO-type operations.

Data is accessed and stored in the RAM by the protocol handler and TIC interconnection control using direct memory access protocol.

The RAM is also used as buffer space for messages to be passed from the ring to the TIC bus interconnection, and messages to be passed from the TIC bus interconnection to the ring.

Access to the buffer space by the protocol handler and the TIC bus control is also controlled by the microprocessor.

Transfers into and out of the RAM are performed using direct memory access (DMA) protocols.

TIC Bus Interconnection Control

The TIC interconnection control provides a mechanism for transferring data between TIC storage (RAM) and CCU storage, via cycle steal. It operates in halfword bus mode.

The function performed by the TIC bus interconnection control can be visualized as a double interface DMA controller with a 128-byte hardware store-and-forward buffer. The 128-byte buffer can logically connect either to the TIC bus interconnection control or to the local bus, but not to both at the same time.

When DMA data transfer is occurring at the TIC bus interconnection control, the TIC is the bus master, and the data can flow in only one direction (read or write) at a time.

In addition to its DMA function, the TIC bus interconnection control can also transfer data to or from TIC storage.

This function is intended for adapter initialization and to obtain TIC status.

Receive Operation

On receive, data is taken from the ring into the front end, where it is reshaped into distortion-free digital signaling elements.

The front end synchronizes itself with the received data stream and develops a clock which is boundary-aligned to the bit stream.

This bit stream, along with the derived clock, is passed to the protocol handler.

The protocol handler converts the encoded data stream into coding usable by the adapter.

By counting received clock pulses, the protocol handler assembles the bit stream into halfwords units.

Parity is generated on the received data de-serialized from the ring to check data validity through the adapter.

During the receive sequence, cyclic redundancy check (CRC) calculation is begun on the received data.

The destination address is compared against the stored values in the protocol handler to determine if the message is to be copied by the adapter. If so, the protocol handler conditions itself to begin the copy, and transfer is started to the message processor.

The destination and source addresses, the physical control field, the data portions, and the CRC characters of the in-progress received message are now passed to the message processor in sequence.

When the end of the CRC-protected field is received, the previously received CRC characters are compared to the calculated CRC.

- If there is a match, message reception is considered complete by the protocol handler.
- If there is a mismatch on the CRC check, the message processor is signalled that the message should not be considered valid.

The message processor assembles into multi-byte blocks the information received from the protocol handler.

When that assembly is complete, the message processor begins a transfer into CCU storage. These segment transfers continue until the complete message has been transferred.

When the transfer is completed, the message processor completes the receive operation by reporting the status of the transfer to the CCU.

Transmit Operation

Data flow during transmit operations is essentially the reverse of that during receive operations.

The message is accumulated by the CCU in CCU storage, and the message processor is set up with the storage location and length information. The message processor then does a storage-to-storage transfer of the message, including the destination and source addresses, from CCU storage to the message processor.

The message processor signals the protocol handler to begin transferring the message from the message processor resident storage into the hardware buffers of the protocol handler.

When the protocol handler senses that a transmission is pending, it begins the transfer into its buffers. After enough characters have been buffered, the protocol handler searches for a free token on the ring. When one is found, the token is changed to a busy token.

The control characters are generated, and transmitted.

Sequential transmission out of the buffers continues with the destination and source addresses.

When the entire information field has been transferred, the protocol handler inserts the CRC characters that have been accumulated in the message.

The protocol handler begins to remove (strip) any data from the ring that is being received.

The incoming data stream is searched for a match of the source address with the address of the TIC .

After a match is found and transmission is complete, the TIC encodes and transmits a free token on the ring.

The transmission of the free token is followed by a continuous transmission of idle characters.

The TIC also begins repeating the received data stream, and the transmit operation is considered complete.

Token-Ring Multiplexor (TRM) Card

The TRM card handles the operations between the CCU and the token-ring interface couplers (TICs).

On one side, the TRM interconnects the CCU and the MOSS through the IOC bus, and on the other side, the TRM interconnects the TICs through the TIC bus.

The TRM functions are:

- Receive and re-drive the lines toward the IOC bus
- Provide the clocking generation
- Perform the daisy chain continuity for the IOC bus serial lines
- Convert PIO operations into MMIO operations
- Convert DMA operations into cycle steal operations
- Can generate three different types of interrupt

- Check the validity of the transactions between the CCU or the MOSS and the TICs.

To perform these functions, several registers are located in the TRM:

- Buffer and the extended buffer
- TIC control register
- Interrupt request and bus request register
- Diagnostic register
- Level 1 error status register
- Level 2 error status register
- MOSS error status register.

IOC Bus Interconnection

The IOC bus interconnection allows communication between the TRAs and the CCU (NCP), or between the TRAs and the MOSS.

The IOC bus signal lines go to/from the TRM card bottom connector I/O pins.

See Chapter 3, "Buses and Switching" for more information.

Summary of the IOC Bus Interface Signal Lines

Signal Line Names	Mnemonic	Initiated by	PIO/TRM	AIO	Interrupt
Card present IN	+ PREIN	Adp.before	X	X	
Card present OUT	+ PREOUT	TRM	X	X	
Cycle steal request high	+ CSRH	TRM		X	
Cycle steal grant high	+ CSGH	CCU		X	
Cycle steal grant high previous	+ CSGHP	CCU		X	
Cycle steal priority line	+ CSPRY	TRM/adapt.		X	
CSG through tag	+ CSGT	TRM		X	
IOC data bus	+DO - +D15	TRM/CCU	X	X	X
End of chain	+ EOC	TRM		X	
Halt	+ HALT	CCU	X	X	
Input/output	+ I/O	CCU	X	X	
Interrupt request removed	+ IRR	TRM	X	X	
Interrupt to MOSS	+ITMOSS	TRM	X	X	X
Level 2 priority line	+L2PRY	TRM/adapt.			X
Level 2 serial select line in	+L2SSLIN	Adp.before			X
Level 2 serial select line in previous	+L2SSINP	Adp.prev.			X
Level 2 serial select line out	+L2SSL0U	Adp.prev.			X
Modifier	+ M	TRM		X	
Parity valid	+ PV	TRM	X	X	
Parities	+P0,+P1	TRM/CCU	X	X	X
Power on reset	- POR	Power blck			
Reset	+ RESET	Switch			
TA	+ TA	CCU	X		
TD	+ TD	CCU	X	X	
Valid halfword	+ VH	TRM	X	X	X
Valid byte	+ VB	TRM		X	

Figure 6-14. Summary of the IOC Bus Interconnection Signal Lines

TIC Bus Interconnection

The TIC bus is a bidirectional bus which connects the TRM card to the TIC cards via the card bottom connector I/O pins and the board.

Three types of operation are used on this interface:

- Direct memory access (DMA)
- Memory mapped input/output (MMIO)
- Interrupt acknowledgement (IACK).

DMA Operation The DMA operation allows transferring a burst of data between the TRM and the TIC.: During DMA operations, the TIC controls the bus and the TRM is the tributary unit.

MMIO Operation The MMIO allows access to the registers of the IOC interconnection control of the TIC.

Interrupt Acknowledge (IACK) Operation Interrupt acknowledge (IACK) cycles are used to access a vector in the TIC when the TIC requests an interrupt to the TRM. The vector indicates the cause of the interrupt.

Summary of the TIC Bus Signal Lines

Signal Line Names	Mnemonic	Initiated by	PIO/MMIO	DMA	Interrupt
Address bus	+A1, +A2, +A3 - +A23, +APL, +APH, +APX, +A0	TRM, TIC	X	X	
Data bus	+D0 - +D15, +DPL, +DPH	TRM, TIC	X	X	X
Address strobe	- AS	TRM, TIC	X	X	X
Card select(2)	- CS	TRM	X		
Read/write	- RNW	TRM, TIC	X	X	X
Upper data strobe	- UDS	TRM, TIC	X	X	X
Lower data strobe	- LDS	TRM, TIC	X	X	X
Data transfer acknowledge	- DTACK	TRM, TIC	X	X	X
Bus error	- BERR	TRM		X	
Bus request(2)	- BR	TIC		X	
Bus grant(2)	- BGR	TRM		X	
Bus busy	- BBSY	TIC		X	
Bus release	- BRLS			X	
Interrupt request (2)	- IR	TIC			X
Interrupt acknowledge(2)	- IACK	TRM			X
Reset (2)	- RESET	TRM			
System clock	+ BCLK	TRM	X	X	X
System last Transfer	- SLT	TIC		X	

Figure 6-15. Summary of the TIC Bus Signal Lines

TRM Arbitration Mechanism

Since two TIC cards can be attached to the TRM, the TRM can simultaneously receive up to two bus requests for DMA, and up to two interrupt requests from the TIC cards.

The arbitration logic comprises two scan wheels, one for bus requests (BR), the other for interrupt requests (IR). Each wheel in turn can point to either of the two attached TICs.

TRA Resets

Three functions are implemented to reset the TRA (TRM and TICs) or a part of the TRA:

1. The power-ON/tag reset function
2. The programmed reset function
3. The TIC reset function.

Power ON Reset and Tag Reset

These resets are activated in two ways:

1. By the power-ON reset line coming from the power blocks.
2. By the reset tag coming from the switch card.

It completely resets the TRA:

- All requests on the IOC bus are deactivated.
- The TRM reset bit is forced ON in the TRM control register (which indicates a reset has been done).
- The TIC reset bits are forced ON (and the reset leads on the TIC bus) in the TIC control register.
- All the interrupts and their associated statuses are reset.
- The disconnect bit and the CCU PIO disable bit are reset.
- The entire control logic is forced to idle state.
- The BR and IR scan wheel is pointed to the TIC 1.
- More generally, all other functions and all other registers are forced in their inactive state.

Programmed Reset

The programmed reset is initiated by a PIO (IOH or MIOH). It allows the program to reset the TRM without resetting the attached TIC(s) and the connect or disconnect state of the TRM.

The result is the same as the hardware reset except the TIC reset bits, the disconnect mode latch, and the CCU PIO disabled latch are left in their current state.

TIC Reset

The program can perform a selective reset of the TIC by setting or resetting the TIC control register TIC reset bit. The reset bits are connected to the TIC reset leads on the TIC bus. The reset lead is active as long as the reset bit is ON in the TIC control register. The TIC reset lead causes the TIC to disconnect itself from the ring and perform a reset.

Diagnostic Section TA0A

The TRM must be 'disconnected' before running the diagnostic section TA0A. The 'disconnect' command must be performed after each power-OFF to power-ON.

Error Detection and Reporting

TRM Level 1 Error Status Register

TD Field

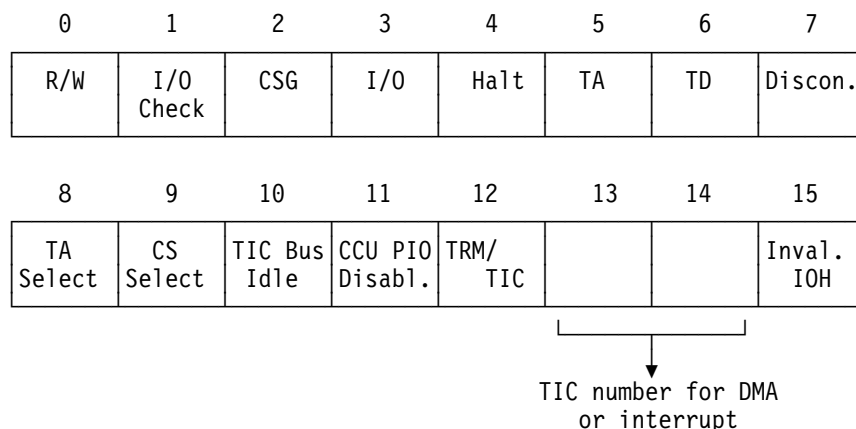

Level 1 interrupts can be generated by the:

- TRM on disconnect
- IOC on time out, bus-in parity, CSCW, storage protect or address exception errors.

Error reporting using IOC level 1 interrupts is limited to errors occurring on the IOC bus and errors detected by the IOC.

TRM internal errors and the TIC interconnection errors found during PIO/MMIO, DMA/CS, or read interrupt vector operations, are reported by a level 2 interrupt for the appropriate TIC.

The pattern in the level 1 status register for a disconnect level 1 interrupt has the following value B'1000000100000000'.

When the CCU IOC logic detects an error, it raises the halt tag.

When the TRM detects the halt tag, it sets the level 1 status register with the exception of bits 7 and 11.

Bits 7 and 11 reflect the status of the indicated latches when the get level 1 error status register PIO is executed.

During an IOC level 1 interrupt, bits 0-3, 5-6, 8-10 and 12-15 are valid only if bit 4 is ON.

- Bit 0** This bit (R/W bit) is ON if a read PIO/AIO is being executed. It is OFF if a write PIO/AIO is being executed. The R/W bit is always ON for a disconnect level 1 interrupt. It is valid only if bit 8 or 9 is ON for an IOC level 1 interrupt.
- Bit 1** This bit (I/O check) is ON if the TRM detects a parity error on the IOC bus when the halt tag is activated.
- Bit 2** This bit (CSG) is ON if the CSG tag in the TRM is active when the halt tag is activated.
- Bit 3** This bit (I/O) is ON if the I/O tag in the TRM is active when the halt tag is activated.
- Bit 4** This bit (halt) is ON if the TRM has detected the activation of the halt tag on the IOC.
- Bit 5** This bit (TA) is ON if the TA tag into the TRM is active when the halt tag is activated.

- Bit 6** This bit (TD) is ON if the TD tag into the TRM is active when the halt tag is activated.
- Bit 7** This bit (disconnect) is ON if the TRM is in disconnect mode when the read level 1 error status register PIO is executed.
- Bit 8** This bit (TA select) is ON if the TRM has recognized its address (with good parity) and the PIO has not completed when the halt tag is activated.
- Bit 9** This bit (CS select) is ON if the TRM has trapped CSG for an AIO and the AIO has not completed when the halt tag is activated.
- Bit 10** This bit (TIC bus idle) is ON if the TRM detects that the TIC bus is idle when the halt tag is activated.
- Bit 11** This bit (CCU PIO disable) is ON if the TRM is disabled for CCU PIOs when the read level 1 error status register is executed.
- If the TRM is CCU PIO disabled, the level 1 error status register can be successfully read only by an MIOH.
- Bit 12** This bit (TRM/TIC) is ON if an AIO or a get line ID PIO is being executed by the TRM when the halt tag is activated.
- If this bit is ON, it means that bits 13 and 14 are valid.
 If this bit is OFF, it means that the error cannot be associated with any particular TIC.
- Bits 13 and 14** Bits 13 and 14 are used to encode the TIC number for some errors.
- During a cycle steal operation, bits 13 and 14 are used to identify the TIC that was doing the DMA operation when the halt tag was received. They also indicate the originator of the level 2 interrupt for an error during a get line ID PIO. These bits are valid only if bit 12 is ON.
- 00=TIC 1
 01=TIC 2
- Bit 15** This bit (invalid IOH) is ON if the TRM decodes an invalid PIO type when the halt tag is activated. This bit is valid only if bit 5 is ON.

TRM Level 2 Error Status Registers

The TRM provides two level 2 status registers (one per TIC).

The level 2 status information is set by the TRM when an error is found in the TRM (not on the IOC bus), an error is detected on the TIC interconnection, or the TIC requests an interrupt.

This information can be read by the program through a get TRM level 2 error status command. The error or status is reset if the PIO read operation completes with no errors. After the status is successfully read, the TRM is able to log another error or status.

FORMAT 1 (Error Detected by TRM)

TD Field Byte 0 (Byte 1 not Used)

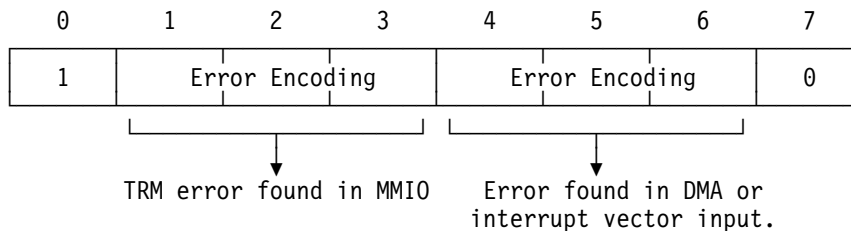

Error Encoding:

0 0 0 No error
0 0 1 TRM internal
0 1 0 TIC interconnection type 1
0 1 1 TIC interconnection type 2

Internal The TRM is suspected.

Type 1 The working TIC is suspected.

Type 2 All TICs can be suspected (idle state error).

This error encoding is performed by the TRM using the checkers in the TRM (See "Error Detection and Reporting" on page 6-20).

The status provides two independent error fields:

1. PIO/MMIO operations which require program retry
2. Operations which do not require program retries:
 - DMA (TIC retries automatically)
 - Input interrupt vector (TRM automatically retries)

Both fields can be significant at a given time.

When a field is set, another error will not be set in the same field until it is reset by a successful 'get TRM level 2 error status'.

A DMA or input interrupt vector operation is retried automatically when the error in the level 2 error status register is reset by a successful 'get TRM level 2 error status' PIO.

FORMAT 2 (Interrupt Request by the TIC)

TD Field Byte 0 (Byte 1 not Used)

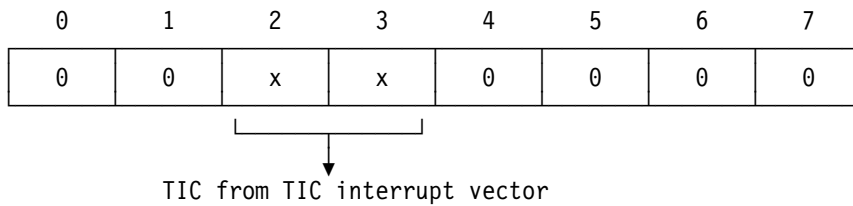

Format 2 is used when a TIC requests an interrupt.

The contents of this register will be:

- B'00100000' for the SCB clear vector.
- B'00010000' for the adapter check vector.
- B'00000000' or B'00110000' for the other TIC vectors.

NCP initializes the TIC interrupt vectors to

- B'xx10xxxx' for SCB clear.
- B'xx01xxxx' for adapter check.
- B'xx00xxxx' or B'xx11xxxx' for the remainder.

A format 1 entry will cause the type B line ID to be used.

A format 2 entry with bits 2 and 3 = B'10' or B'01' will also use the type B line ID. All other cases use the type A line ID (See next paragraph "Line Identification (Line ID) Generation" for type line ID definitions).

If the level 2 error status register contains a format 2 entry and the TRM detects an error that requires logging a format 1 entry, the TRM will overlay the format 2 entry.

After the format 1 entry is read and reset, the interrupt vector will again be fetched from the TIC and the format 2 entry set in the register again.

Line Identification (Line ID) Generation When the CP receives a level 2 interrupt, it places a PIO get line ID command on the IOC bus.: This command is decoded by all adapters. However only one, according to the level 2 interrupt priority mechanism, will answer with a line ID.

For adapters set to the same priority, the first adapter on the IOC bus will be serviced first.

The line ID allows the program to identify the requesting adapter and to process the interrupt.

There are 2 different line IDs per TIC:

- Type A. For the TIC interrupts for which the system status is cycle-stolen to the CCU.
- Type B. For the TIC interrupts for which the system status is not cycle-stolen to the CCU (SCB clear or adapter check) and interrupts generated for TRM-detected errors.

The get line ID command resets the level 2 interrupt and the TRM is now free for another operation including an interrupt (IR) from another TIC.

The CCU interrupt code sequence ends with a reset interrupt PIO/MMIO to the concerned TIC.

The TIC will lower its interrupt line and this will allow the TRM to treat another interrupt coming from the same TIC. In its turn the TIC is free for other operations.

MOSS Error Status Register

Format 1 is used for errors detected by TRM in MOSS PIO/MMIO operations or in direct memory access (DMA) operations (TIC to CCU storage).

TD Field Byte 0 (Byte 1 not Used)

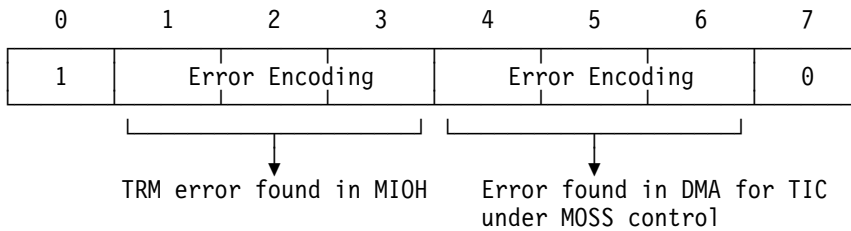

Error encoding:

- 0 0 0 No error
- 0 0 1 TRM internal
- 0 1 0 TIC interconnection type 1
- 0 1 1 TIC interconnection type 2

Internal The TRM is suspected.

Type 1 The working TIC is suspected.

Type 2 All TICs are suspected.

The MOSS error status register is used to log errors associated with MOSS operations. If a MOSS control bit in the TIC control register is ON, all MMIO and DMA errors for that TIC will be logged in the MOSS error status register.

If the TRM is connected, all MIOH/MMIO errors will be logged in the MOSS error status register.

If the TRM is disconnected and the associated MOSS control bit is OFF, all MMIO and DMA errors for a TIC are logged in the normal level 2 error status register.

Format 2 is not used for the MOSS error status register.

TIC Adapter Check Register

The adapter check interrupt is generated when the TIC has encountered an unrecoverable hardware or microcode error. In this case the TIC is waiting for a reset.

The reason for the TIC check is located in 8 bytes beginning at address X'05E0'. The TIC check status is defined as follows:

X'5E0' (TIC adapter storage)

Byte 0 and 1	Byte 2 and 3	Byte 4 and 5	Byte 6 and 7
Adapter check	Parameter 0	Parameter 1	Parameter 2

Each bit of the TIC adapter check gives the error type and the contents of parameters 0 to 2 give additional information. More details are given in the following table.

TIC Adapter Check Register Decoding Byte 0

Bit	Error Type	Error Description	Parameters 0-2 Contents
x...	MMIO parity error	Data parity error between CCU and TIC	Contents is ignored
.x...	DMA abort read	DMA read operation abort for time out or parity error or bus error	Parm 0=0000 time out error 0001 parity error 0002 bus error Parms 1-2 contain the failing CCU address + or - 6 Bytes
..x.	DMA abort write	DMA write operation abort	Same as for DMA abort-read
...x	Illegal OP code	Illegal OP code detected	Parm 0 = TIC register 13 Parm 1 = TIC register 14 Parm 2 = TIC register 15
.... x...	Parity error	Local bus parity error detected by TIC processor	Same as for illegal OP code
.... .x..	Parity error external	Local bus parity error detected by TIC during operation with CCU	Same as for illegal OP code
.... ..x.	Parity error - IOC bus interf.	Local bus parity error detected by TIC during operation with CCU	Same as for illegal OP code
.... ...x	Parity error PH (protocol handler)	Local bus parity error detected by TIC during operation with the protocol handler	Same as for illegal OP code

TIC Adapter Check Register Decoding Byte 1

Bit	Error Type	Error Description	Parameters 0-2 Contents
x...	Parity error receive	Local bus parity error detected by TIC during receive operation	Parm 0 = buffer address
.x..	Parity error transmit	Local bus parity error detected by TIC during transmit operation	Parm 0 = buffer address
..x.	Ring underrun	DMA underrun detected during ring transmit	Parms 0-2 are ignored
...x	Ring overrun	DMA overrun detected during receive operation	Parms 0-2 are ignored
.... x...	Invalid interrupt	Unrecognized error interrupt was generated	Parm 0 = TIC register 13 Parm 1 = TIC register 14 Parm 2 = TIC register 15
.... .x..	Invalid error interrupt	Unrecognized error interrupt was generated	Parm 0 = TIC register 13 Parm 1 = TIC register 14 Parm 2 = TIC register 15
.... ..x.	Invalid XOP	Unrecognized transmit operation request was generated	Parm 0 = TIC register 13 Parm 1 = TIC register 14 Parm 2 = TIC register 15
.... ...x	Program check	TIC processor program check detected	Parm 0 = ABEND code Parm 1 = Address location that detected the error

Problem Determination Aid

Token-Ring Wrap Tests

Using NCP Under NCP a wrap test is performed at each TIC open command processing as a first step before inserting itself into the ring. The TIC internal lobe media test, tests the ring up to and including the logic (relay contact normally closed) pertaining to the position of the IBM 8228 MSAU or equivalent where the lobe connector is plugged-in (the 8228 is a wiring concentrator). It also tests the ring up to the point where it is unplugged before the 8228. (that is, at the tailgate, at the wall connector, and so on.)

The lobe media test is only invoked on the open command and is not performed as a result of the reset or initialization commands.

Note that a disconnected cable during the lobe media test will cause a lobe wire fault check to appear in both the display token-ring status function and the ring status field (field E) of the token-ring interconnect function. (Refer to the *Problem Determination Guide*, GA33-0096.)

When a lobe wire fault is detected the TIC will be frozen and the status will remain unchanged until the next open is issued.

Using TRA Diagnostics Using the TRA diagnostic routine TG01, a wrap test is also performed up to and including the 8228 or up to the point at which the ring is unplugged before the 8228.

Diagnostic Section TA0A: The TRM must be 'disconnected' before running the diagnostic section TA0A. The 'disconnect' command must be performed after each power-OFF to power-ON. However, no open commands are issued by the diagnostic routine so a lobe wire fault will not be detected.

Chapter 7. Channel Adapter (CA)

The CA in 3745 Models 130, 150, 160, and 170 Data Flow	7-2
The CA in 3745 Model 17A Data Flow	7-3
Introduction	7-4
Buffer Chaining Channel Adapter (BCCA)	7-4
Packaging	7-4
Supported Features	7-5
Non-Supported Features	7-5
Configuration	7-5
CA Operating Environment	7-8
Modes of Operation	7-8
Host Unit Control Word (UCW)/Host I/O Configuration Data Set (IOCDS)	7-8
Overall Operation	7-9
Data Transfer Methods (PIO and AIO)	7-9
CA Instructions	7-9
CA States	7-9
CA Interrupt Requests	7-10
Accessing CA Registers	7-10
Channel Interface Tag Signals Used by the CA	7-11
Autoselection	7-12
Autoselection Mechanism	7-12
Autoselection (AS) Chain	7-12
Autoselection Error	7-13
Cycle Steal	7-14
Cycle Steal (CS) Chain	7-14
Removing a CA from the Cycle Steal Chain	7-14
CA/MOSS Connection	7-15
Interrupt Requests	7-16
Level 1 Interrupt Request	7-16
Level 3 Interrupt Request	7-16
Two-Processor Switch (TPS)	7-17
TPS/TCS Mode	7-17
Loosely Coupled Host Attachment	7-17
Alternate Path Host Attachment	7-17
Alternate Path Host Operations	7-18
Presentation of Status	7-19
Effect of System Reset	7-19
Effect of Selective Reset	7-20
Channel Stop	7-21
Interface Disconnect	7-21
I/O Error Alert	7-21
Testing and Checking Hardware	7-22
Autodiagnostics	7-22
Functions Provided by Diagnostic Program	7-22
CA Interface Wrap Plugs	7-23
CA Services	7-24
CA Interface Display	7-24
CA Initialization	7-24
Initialization First Part (Checkout)	7-24
Initialization Second Part	7-25
Initialization Third Part (Chaining)	7-25

The CA in 3745 Models 130, 150, 160, and 170 Data Flow

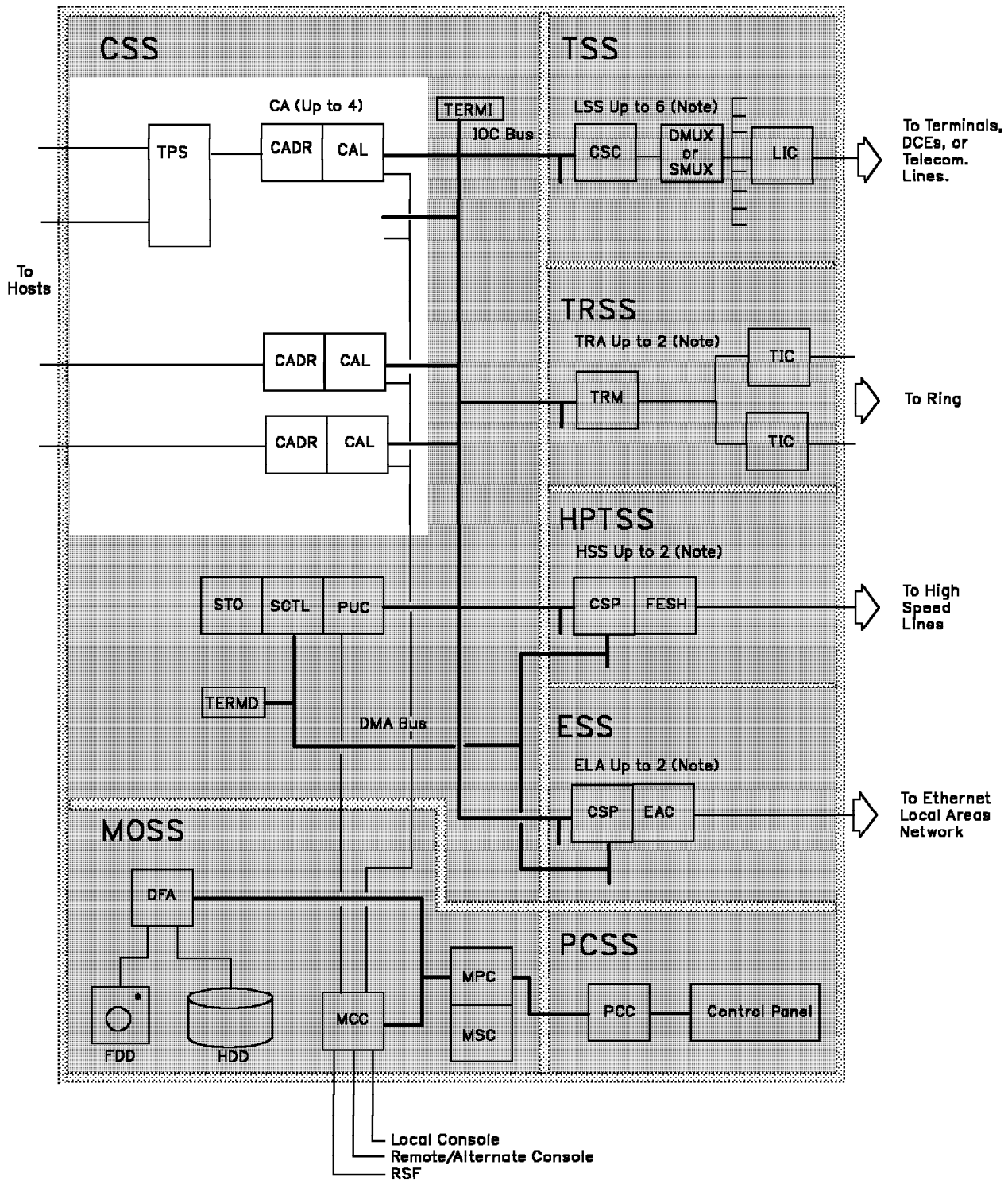

(Note) The number of LSS+HSS+ELA does not exceed 6

The CA in 3745 Model 17A Data Flow

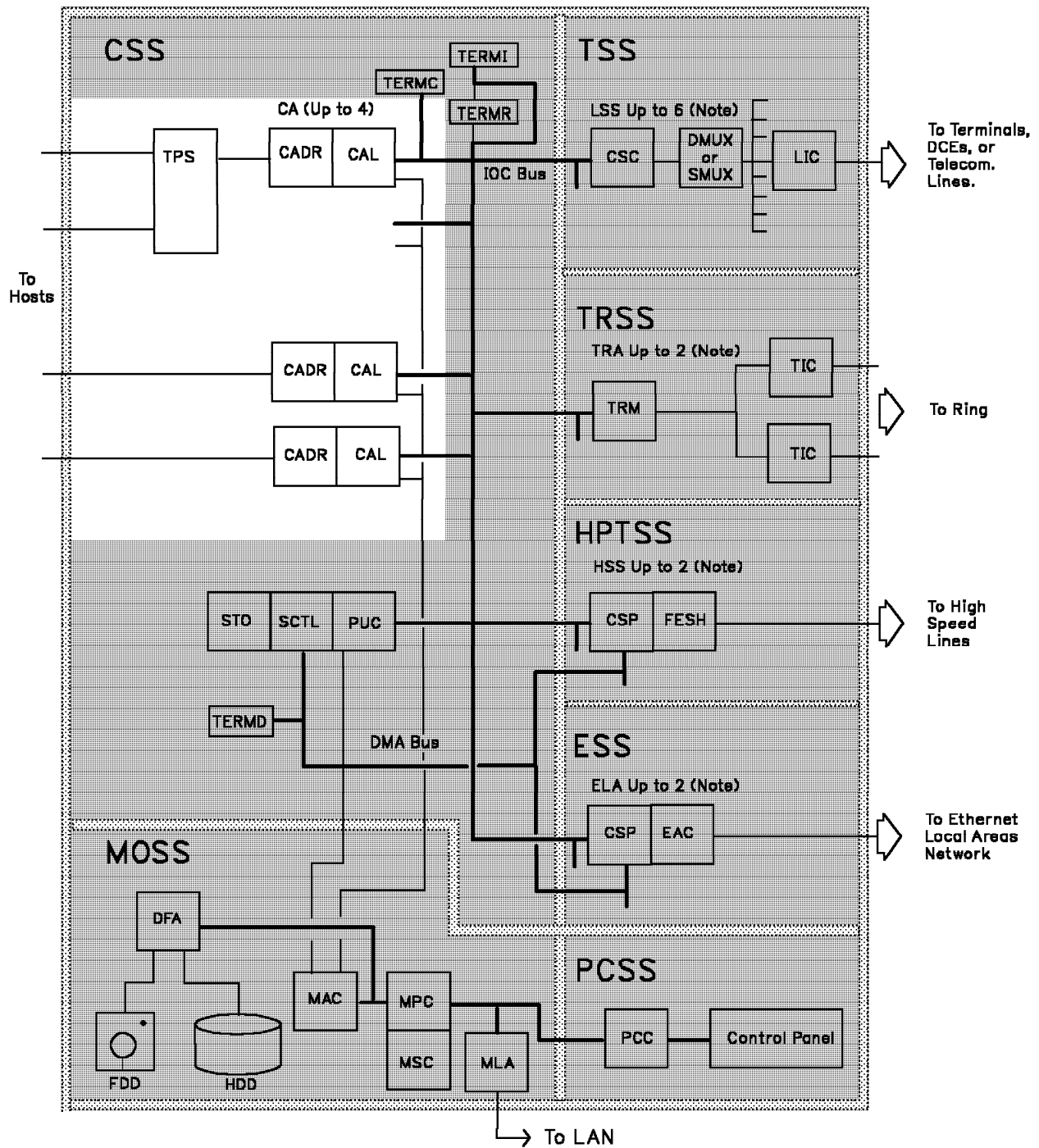

(Note) The number of LSS+HSS+ELA does not exceed 6

Figure 7-1. The CA in 3745 Model 17A Data Flow. For model 17A, DMA and IOC buses are connected to the CBC in the 3746-900. This MLA card links the MOSS to the Service Processor through a LAN.

Introduction

The microcoded CA attaches the 3745 Communication Controller to one or more System 308X/309X/4341/4361 (for **CADS** only) /4381/9370/ES/9000 host processors via selector, block multiplexor, or byte multiplexor channels.

The 3745 supports the channel adapter data streaming (CADS) (CA type 6), and the buffer chaining channel adapter (BCCA) (CA type 7).

From the 3745 MOSS console, an operator can:

- Enable/disable a CA
- Reset a CA
- Display a CA status
- Display CA storage and registers
- Display CA initialization parameters
- Enter/modify CA initialization parameters
- Get a CA dump
- Start/stop a CA trace
- Allow CA concurrent maintenance.

Buffer Chaining Channel Adapter (BCCA)

The **BCCA** is a new type of channel adapter which improved the performance capability. The BCCA is based on CADS design and improves the CADS throughput and channel efficiency. Without NCP intervention, the BCCA handles buffer chaining in write channel program, and both buffer chaining and PIU chaining in read channel program.

BCCA and CADS may be mixed in the 3745. The BCCA operates in native mode only under the Network Control Program (NCP), it does not support the Partitioned Emulation Program (PEP).

The BCCA acts as a CADS when buffer chaining mode is not set, except that it does not support ESC mode.

Note:

In the following pages, specifics of a **type 7 CA** will be indicated by **BCCA**. **CA** stands for **CADS** and **BCCA**.

Packaging

One CADS or BCCA is packaged on one channel adapter logic (CAL) card, and one channel adapter driver/receiver (CADR) card (see Figure 7-3 on page 7-6). See page YZ 052 for CA board and I/O bus test points.

A built-in two-processor switch (TPS) feature is available. The TPS allows a single CA to connect two separate host channels (TCS mode), or two channels of a single host (TPS mode). A CA can have two host interfaces (TPS operative) by adding a second CADR card. Only odd-numbered CAs support the TPS feature (see Figure 7-2 on page 7-6). If a CA is equipped with the TPS support, the next CA cannot be installed. A bypass card assuring serial line continuity must be installed instead.

Refer to Figure 7-4 on page 7-7 for a diagram of components and interconnections.

Supported Features

The following features are supported by **CADS** and **BCCA**:

- I/O error alert
- Two-processor switch (TPS)
- High speed transfer (Data in/Data out)
- Data streaming with selectable speeds for 1 MB, 2 MB, 3 MB or 4.5 MB channel speed. These values are the host channel speeds, not the actual transfer rates which are much lower. (The 3745 may be connected to a 4.5 MB channel attachment even if operating at its own speed. In this case, it must be attached beyond the last control unit on the I/O interface which is capable of the 4.5-MB data-transfer rate.)

WARNING: Data streaming cannot be used when the 3745 is connected to systems 308X or 43XX. When a CA defined with the data streaming option is connected to a host which does not support data streaming, abend code 300A is issued.

Non-Supported Features

The following features are not supported:

- Bus extension
- Command retry
- Suppress data (interlock transfer)
- Dynamic reconnection

Configuration

Four channel interfaces are available by means of the IOC BUS. The maximum configuration is four CAs without TPS, or two CAs with TPS. Thus, a maximum of 4 channel interfaces may be installed on a 3745, numbered from 5 to 8.

The Control Program (CP) addresses the CAs by way of the IOC BUS as shown in the following table (Table 7-1):

CP Address	Channel Addressed
000	CA 5
001	CA 6
010	CA 7
011	CA 8

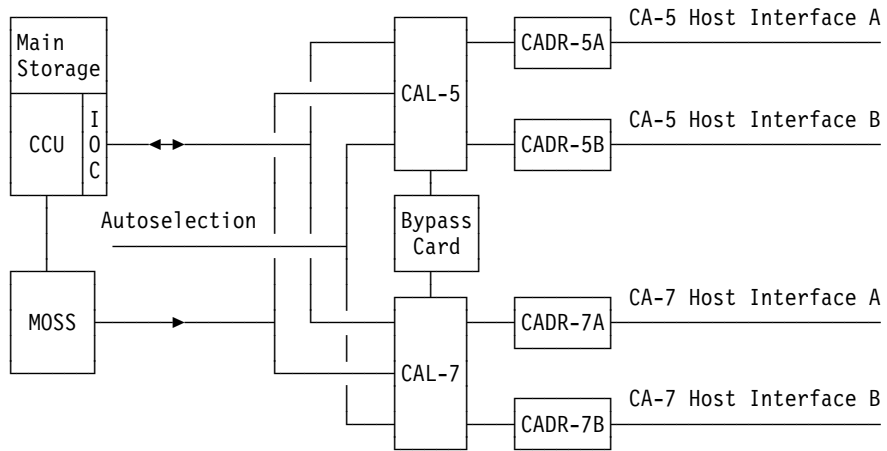

Figure 7-2. CA Configuration with TPS Feature

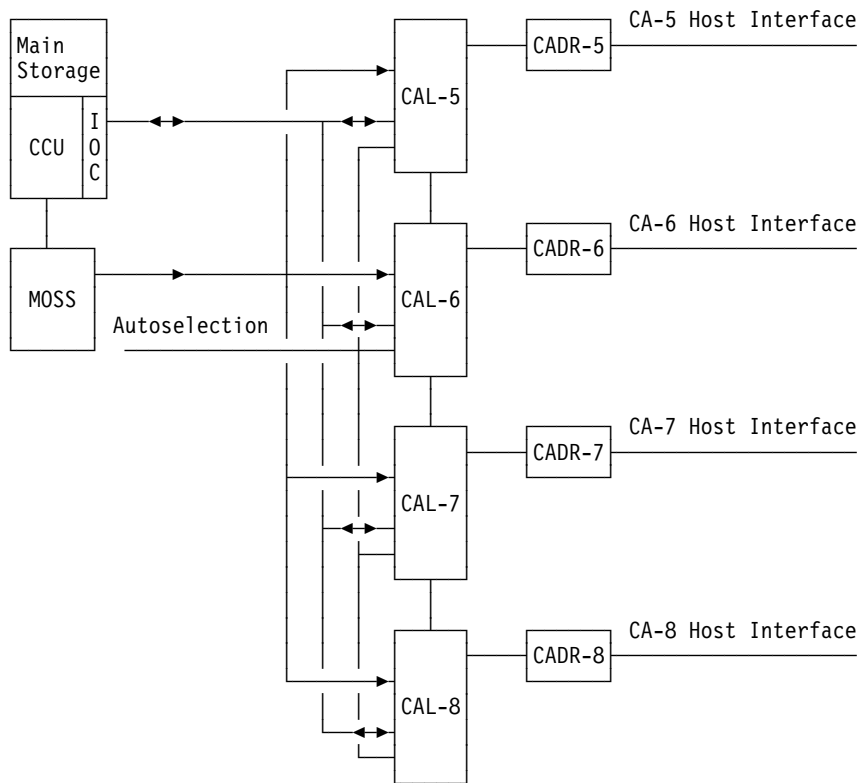

Figure 7-3. CA Configuration without TPS Feature

CA Operating Environment

The CA is used by the 3745 control program (NCP or PEP) to communicate with an application program in the host(s) through various telecommunication access methods.

Physically, channel interface tags and buses attach the CA to the host channels, and IOC buses attach internally the CA to the CCU.

Modes of Operation

The CA can run in either native subchannel (NSC) mode or in emulation subchannel (ESC) mode. The CA operates in the following modes:

- NSC with the Network Control Program (NCP)
- NSC and ESC simultaneously with the Partitioned Emulation Program (PEP)

Notes:

1. With PEP, the NSC is used for loading and dumping.
2. Initial program load (IPL) must always be done in NSC mode.
3. **BCCA** works only in native mode (NCP).

NSC Mode

The NSC mode is supported for all types of host channel (byte multiplex, selector, or block multiplex), and allows servicing any number of lines using only one host subchannel address. Line address decoding is handled entirely by the NCP.

ESC Mode

The ESC mode is supported for byte multiplex channels only, and allows the controller to emulate the 2701 Data Adapter Unit, 2702 Transmission Control, and 2703 Transmission Control using existing host programs and subchannel addresses. This mode requires the Partitioned Emulation Program (PEP) in the 3745, and a separate subchannel address for each PEP line. The ESC mode is not supported with BCCA.

Host Unit Control Word (UCW)/Host I/O Configuration Data Set (IOCDS)

The host system UCW/IOCDS requirements for the controller vary according to the type of control program and features. They are described in the appropriate host *I/O Configuration Program (IOCP) User's Guide and Reference*. UCW/IOCDS requirements are determined as follows:

- One UCW/IOCDS is required for each unique NSC address.
- An additional UCW/IOCDS is required for each emulated subchannel address. For example, a controller running PEP with two ESCs needs three UCW/IOCDS.
- All UCW/IOCDS must be unshared and unfolded.

Overall Operation

The CA is connected to the 370 channel and to the IOC bus, and enables communications over these two data paths.

Data Transfer Methods (PIO and AIO)

Two methods are used to transfer data between the CA and the CCU (via the IOC bus, the switching device, and the adapter bus):

- **Program-initiated operation (PIO):**

PIO mode provides data buffering for up to four bytes, with program intervention required every four bytes.

PIO mode may be used when performance is not critical.

- **Adapter-initiated operation (AIO):**

- When the buffer chaining mode is not set, AIO mode provides a 255-byte buffering. A program intervention is required after each 255-bytes transfer.
- When the buffer chaining mode is set, **BCCA** provides two 255-bytes buffers. A program intervention is required at end of PIU in the write channel program, or at end of PIU chain in the read channel program.

AIO mode should always be used when performance is critical.

CA Instructions

The CA is controlled by instructions issued from the control program.

The NCP and PEP exclusively use adapter input/output halfword (IOH) instructions and input/output immediate halfword (IOHI) instructions.

These instructions examine or set the CA registers, load or read buffers, and initiate cycle stealing.

Note: Throughout this chapter, the channel IOH/IOHI instructions are referred to as input X'nn' or output X'nn'.

CA States

The CA may be in one of the following states:

- **Ready**

In the ready state, the CA accepts instructions, but is not in one of the three active states (initial selection, data transfer, or status transfer).

- **Initial Selection**

The CA enters the initial selection state when an initial selection is started by the host processor. The CA continuously monitors its channel interface for one of its assigned addresses. When it detects one of these addresses, the CA enters the initial selection state, and proceeds with the operation.

- **Data Transfer**

The CA enters the data transfer state when the control program initiates a data transfer sequence. Data is transferred across the interface from the host channel to the CA, or from the CA to the host, by the hardware.

- **Status Transfer**

The CA enters the status transfer state when the control program initiates a status transfer sequence.

- **Disabled**

When the CA is in the disabled state, it does not reply to selection signals coming from the host.

CA Interrupt Requests

The CA can raise interrupt requests to the CCU at level 1 and level 3 (normal mode), and interrupt requests to MOSS at level 1 and level 4 when the MOSS is the owner of the resource.

- **Level 1 Interrupt**

Level 1 interrupt requests to the CCU are caused by check or error conditions.

Level 1 interrupt requests to MOSS are caused by check or error conditions when the MOSS is the owner of the resource (IPL).

- **Level 3 Interrupt**

(See "Level 3 Interrupt Request" on page 7-16.) Level 3 interrupt requests are caused by:

1. Initial selection interrupt requests.
2. Data/status interrupt requests.

- **Level 4 Interrupt**

Level 4 interrupt requests are raised to MOSS in diagnostic mode only.

Accessing CA Registers

The CA registers are accessed by:

- CCU input/output (IOH) or input/output immediate (IOHI) instructions from the CP.
- MOSS input/output (MIOH) instructions, used to initialize or diagnose the CA from MOSS.
- The operator selecting the CA services when using MOSS functions.

The CCU IOH and IOHI instructions are used to transfer the contents of one of the CCU general registers to a selected CA register, or conversely.

Channel Interface Tag Signals Used by the CA

Address in
Address out
Bus in
Bus out
Command out
Data in ¹
Data out ¹
Disconnect in
Operational in
Operational out
Request in
Select in
Select out, and Hold out
Service in
Service out
Status in
Suppress out

¹ Used only with 'High Speed Transfer' and 'Data Streaming' options.

Autoselection

In order to work with a CA, the control program must first select that CA. Two methods are available: output X'07' giving the CA address, or autoselection.

Autoselection Mechanism

To perform autoselection, a CA must already be selected, and an output X'07' with bit 0.0 = 1 (enable autoselection) must be executed.

Autoselection will be effective on an input X'0F' execution. At that time, the CA having the highest priority pending level 3 interrupt becomes automatically selected, and the currently selected CA will deselect. If no CA has a level 3 interrupt request, the previously selected CA remains selected.

The priority for the level 3 autoselection mechanism is as follows (from highest to lowest):

1. Priority outbound data transfer L3 interrupt (output X'02' bit 1.4 = 1).
2. Other level 3 interrupts (see "Level 3 Interrupt Request" on page 7-16).

Autoselection (AS) Chain

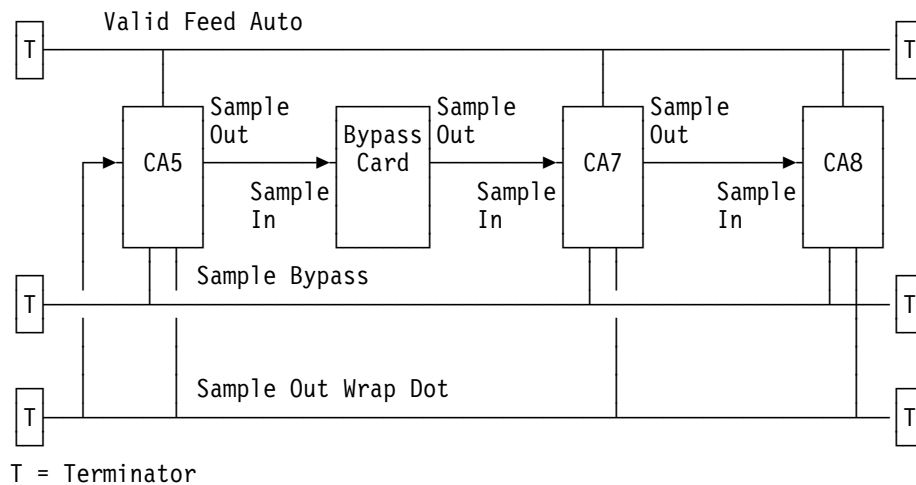

Figure 7-5. Example of Autoselection Chain

The AS chain allows up to four CAs to be installed without specific jumpering, that would be configuration-dependent. The AS chain carries the following signals:

- **Valid Feed Auto:** A bi-directional line is used to synchronize the IOC bus 'Valid Tag' line for all PIO broadcast commands.
- **Sample Out:** Unidirectional line going out from the CA. This line is addressed to the next installed CA in the loop if it has not been removed from the AS chain. The 'Sample Out' line is connected to the 'Sample In' line of the next installed CA.
- **Sample In:** If the previous CA is installed, this line is connected to 'Sample Out' of the previous CA.
- **Sample Bypass:** Bidirectional line used to bypass the CA if the previous CA, or the next installed CA, has been removed.

- **Sample Out Wrap Dot:** Unidirectional line going out from the CA, used by the last CA installed and returned to the first CA (CA 5).

'CA Sample Out' connects all CAs. This line enables the circular-poll function of the AS sequence. That is, polling for the highest priority interrupt starts with the CA following the previously selected CA (or the one after that, if it is no longer in the AS chain): CA 5 follows CA 8, CA 6 follows CA 5,

Autoselection Error

When the hardware detects a problem on the 'sample' chain, no CA will answer at 'TD' time, and an IOC bus timeout will be set.

The control program must determine the failing CA.

Cycle Steal

In CS operation, the first halfword sent by the CA is the CSCW, in order to make the following information known to the IOC:

- Adapter type
- Adapter address
- Read/Write operation.

Cycle Steal (CS) Chain

Depending on whether the CA is the first installed, or a previous CA is in the CS chain, the CA will have to monitor either:

- 'CS grant low priority' (CSG-L), or
- 'CS grant low-thru-out' (CSG-T), or
- 'CS grant low-bypass-out' (CSG-B).

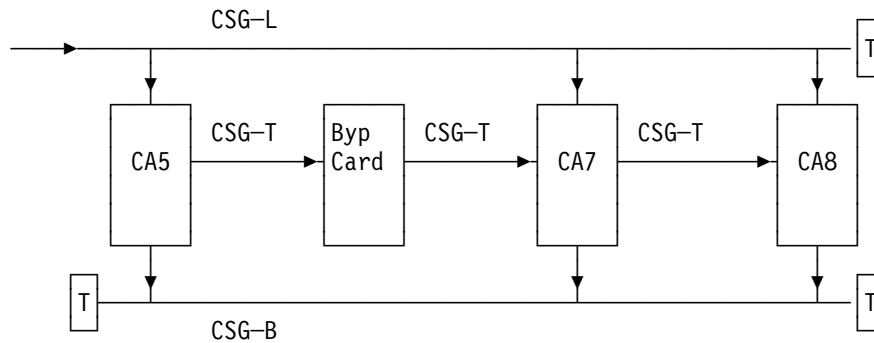

Byp = Bypass
T = Terminator

Figure 7-6. Example of Cycle Steal Chain

Removing a CA from the Cycle Steal Chain

To avoid potential host system hangup, no data transfer must be in progress for the CA which has to be removed from the CS chain.

The control program must remove the CA from the cycle steal chain.

CA/MOSS Connection

A 16-line link connects the MCC card to the channel adapters.

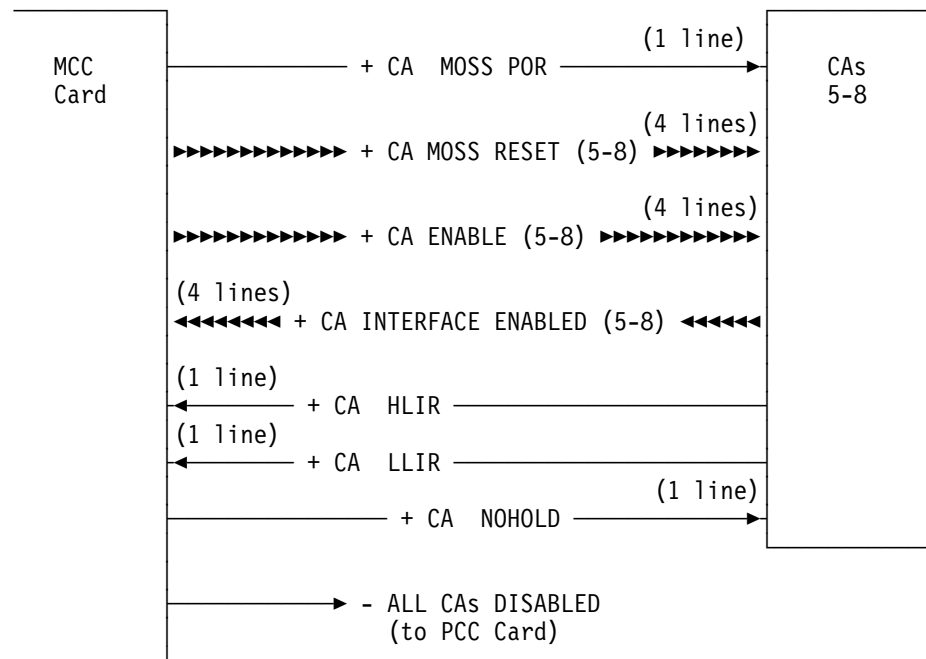

Figure 7-7. CA Link to MOSS

Note: The 'CA NOHOLD' line coming from the MOSS (broadcast line) is used to validate the 'CA MOSS POR', 'CA x MOSS RESET', and 'CA x ENABLE' lines.

Interrupt Requests

The CA generates two major classes of interrupt: CA level 1 and CA level 3 interrupt requests.

Level 1 Interrupt Request

This request is associated with hardware detection of errors in the CA. When an error condition is detected in the CA, a bit is set in the CA level 1 interrupt check bit register X'0D'.

These errors raise a level 1 interrupt request to the CCU by activating IOC bus byte 0, bit 5 (if register X'09' bit 0.4, 'interrupt request disabled', is OFF).

Level 3 Interrupt Request

A CA raises a level 3 interrupt request to the CCU by activating IOC bus byte 1, bit 0 when the I/O is not active (if register X'09' bit 0.4, 'interrupt request disabled', is OFF). There are two types of level 3 interrupt request:

1. CA initial selection request:
 - An initial selection sequence occurs if buffer chaining is not set
 - An initial selection sequence occurs for commands other than Read, TIO or NO-OP when buffer chaining outbound is set
 - An initial selection sequence occurs for commands other than Write, Write-Break, TIO or NO-OP when buffer chaining inbound is set
 - NSC status cleared if buffer chaining is not set
 - A system reset sequence occurs
 - ESC TIO status cleared
 - Selective reset
 - Interface disconnect
 - Channel bus out check
2. Data/status transfer request:
 - End of an inbound data transfer if buffer chaining is not set
 - End of an outbound data transfer if buffer chaining is not set
 - End of a status transfer if buffer chaining is not set
 - End of the last inbound data transfer if buffer chaining is set (for example end of PIU)
 - End of the last outbound data transfer if buffer chaining is set (for example end of PIU chain)
 - Suppress out monitor interrupt.
 - A program requested interrupt occurs.
 - Any CA level 1 check occurs when the adapter is in a data/status transfer sequence.
 - A data streaming time out interrupt occurs
 - A channel bus out check
 - A selective reset or an interface disconnect when the CA is in data/status/IO error alert sequence.

Two-Processor Switch (TPS)

To be operational, the channel interfaces must be enabled. Both channel interfaces may be enabled, but simultaneous operation over the two interfaces is not permitted. Emulator subchannels are not available when both CA interfaces are enabled.

Any interface may be enabled or disabled from the MOSS. If a channel adapter has a TPS and is attached to a loosely-coupled host, or hosts, only one interface may be enabled at a time on the affected channel adapter. Only ESC operation is allowed in this partitioned mode.

TPS/TCS Mode

When the TPS feature is present, either TPS or TCS mode can be selected in the 3745.

- In **TPS mode** the A and B interfaces are connected to the **same host** and can be enabled at the same time.
- In **TCS mode** the A and B interfaces are connected to **two different hosts** and cannot work at the same time.

Loosely Coupled Host Attachment

The term 'loosely coupled' means either:

1. Two separate hosts each running its own access method (VTAM) with each host attached to an interface of a CA with TPS, or
2. A single host running different access methods, one access method associated with one interface of a CA via a TPS, and the other access method associated with the other interface of the same CA.

When running in a loosely coupled environment, only one of the interfaces may be enabled.

Alternate Path Host Attachment

'Alternate path attachment' is a single access method in a single host having access to both interfaces of a CA with TPS. With alternate path, if the access method issues a start I/O over one channel and that channel is busy with another device, the start I/O can then be issued over the alternate channel.

Note: More than one access method can operate in alternate path hosts, but only one can access both interfaces of a CA with TPS.

When running in an alternate path environment, both CA interfaces can be enabled.

Alternate Path Host Operations

The following TPS definitions must be understood:

1. **Neutral:** The CA is not in communication with either interface, and no active commands exist in the CA.
2. **Switched:** The CA is actively communicating with an interface. If the CA is active with a command, all additional communications are to be made through this interface. The switched state comprises three substates:
 - a. **Instantaneous Allegiance:** The CA enters this state when it traps 'select out' during a channel-initiated sequence, or a poll during a control unit-initiated sequence. If the CA presents DE without unit check (UC) during initial selection, and chaining is not indicated, the CA returns to the neutral state.
 - b. **Long-Term or Implicit Allegiance:** The CA enters this state when accepting a command without presenting DE, or when a No-Op is chained to the next command. This state lasts until the CA presents DE without UC to the channel. The CA remains switched to the same interface throughout. If chaining is not indicated and DE is not stacked, the CA returns to the neutral state.
 - c. **Contingent Allegiance:** This state is an extension of long-term allegiance. When a command ends with a UC status (because of some error), the CA enters this state, even though DE is presented to the command. The CA remains switched to the same interface, and does not return to neutral. The host, on receiving the UC status, issues a sense command to determine the cause of the error. The CA returns to neutral when receiving a command other than No-Op or Test I/O.

State	Substate	Meaning
Neutral		No allegiance.
Switched	Instantaneous Allegiance	Initial selection sequence, present async status, present tagged DE.
	Long-Term	From the initial selection till the end of the CCW chain execution.
	Contingent	UC status presented to host during initial selection or final status.
Return Neutral		At command end with DE acceptance and no chaining, DE accepted or stacked after busy, async status accepted or stacked, command other than No-Op or Test I/O in contingent state.

Ending statuses to the host are as follows:

1. **Normal Tagged Status.** This status is presented to the host in response to an initial selection command. The CA remains switched in long-term allegiance to the interface until the control program presents the normal ending status tagged for that interface.
2. **Tagged DE Status.** When the CA has presented a busy status to an interface because the other was in long-term or contingent state, that interface presents

the DE status to the host when the CA returns to the neutral state. This DE status is tagged for that interface by the hardware to clear the busy status previously presented to the host. The tagged DE status frees the host so that it can issue the next command.

3. **Untagged Asynchronous Status.** When operating with tightly coupled processors, the control program can present asynchronous status to the host to initiate a command. This occurs when the CA is in the neutral state with no commands active.

'Request in' is raised to both interfaces, and both interfaces compete for service. The first channel to poll the CA wins. Acceptance of the status causes a level 3 interrupt request, and the CA returns to neutral. If the channel stacks the status, the CA returns to neutral and interrupts the control program. The untagged asynchronous status is then re-offered to both interfaces by the CA when the interrupt is serviced by the control program.

Presentation of Status

Although the CA has two channel interfaces, simultaneous operation of both interfaces is impossible. Therefore, when the CA is switched to one interface, they cannot operate simultaneously. The other interface refuses all channel-initiated sequences. When the CA is in long-term or contingent allegiance on one interface, the other interface presents the status X'10' (short busy sequence) to the channel: When 'select out' is trapped by the non-switched interface, it raises 'status in' and presents X'10'. The host channel responds by dropping 'hold out' or 'select out' and 'address out', thereby disconnecting the interface. The host does not issue further commands until a tagged DE status is received. This status is presented when the active CA interface returns to the neutral state. The CA hardware raises 'request in' and presents the DE status. If the DE status is stacked instead of accepted, the CA automatically tries to present the status again, independently of the control program.

Effect of System Reset

System Reset over Interface with Allegiance: When the CA recognizes the system reset, the CA is completely reset, ending any allegiance condition, and sets an initial selection interrupt request on level 3. However, if a DE status resulting from a previous busy status on the opposite interface is still pending, the CA is not reset.

During system reset, if the opposite channel polls the CA in response to a 'request in' from some other control unit, the resulting 'select out' tag is bypassed. Similarly, any channel-initiated initial selection sequence to either interface causes the CA to switch to that interface, to present the busy status, and to return to the neutral state.

System Reset over Interface without Allegiance: When a system reset occurs on the interface without allegiance, any tagged DE status pending is reset. The rest of the CA is not reset, and no level 3 initial selection interrupt request is made.

System Reset when the CA is in Neutral: When a system reset occurs on a neutral CA, only the pending tagged DE status is reset on the interface, if any. The rest of the CA hardware is not reset, and no level 3 initial selection interrupt request is made.

Note: If a system reset is presented to both interfaces simultaneously, the CA is completely reset, and a level 3 interrupt request is made.

Effect of Selective Reset

Selective Reset over Interface without Allegiance: A selective reset cannot occur on the interface without allegiance. Therefore, the CA hardware is not reset, and no level 3 initial selection interrupt request is made.

Selective Reset over Interface with Allegiance: When the CA recognizes the selective reset, it returns to the neutral state, and issues a level 3 initial selection interrupt request.

No hardware reset occurs, except for a tagged DE status caused by a previous busy status on the opposite interface.

During the initial selection, if the opposite channel polls the CA in response to 'request in' from some other control unit, the resulting 'select out' tag is bypassed.

Similarly, if a channel-initiated initial selection sequence occurs on either interface, the CA switches to that interface, enters the instantaneous allegiance state, presents control unit busy X'70' as the initial status, and returns to the neutral state.

Channel Stop

Channel stop is an error if it occurs during an outbound data transfer. This sequence is detected by the CA hardware when passing bytes over the channel interface. The host processor responds to the CA tag lines 'service in' or 'data in' by raising the 'command out' tag line.

If operating on a byte multiplexer channel, the hardware will disconnect from the channel interface and cause a CA data/status L3 interrupt request.

If operating on a block or selector channel, the hardware will present channel end and request a data/status L3 interrupt. When an input X'02' is executed, bit 0.5 = 1 (channel stop/interface disconnect) will be active.

Interface Disconnect

This condition is detected by the CA hardware when the adapter is either in an initial selection, data transfer or status transfer sequence. 'Operation in' is up, and the host CPU has the 'address out' tag line up, and the 'select out' (hold out) tag line down before the completion of either of the above sequences.

The hardware will then cause either a CA initial L3 interrupt request, or a CA data/status L3 interrupt request, depending on when this condition was detected. Also, the CA will disconnect from the channel interface when working on the channel.

If this condition occurred during an initial selection sequence, the hardware will set 'interface disconnect' which is accessible by an input X'00' instruction (bit 0.1 = 1). If it occurs during a data/status transfer, the hardware will set 'channel stop/interface disconnect' which is accessible by an input X'02' instruction (bit 0.5 = 1).

I/O Error Alert

I/O error alert is a channel interface feature that detects a CA malfunction ('disconnect in' tag line raised).

I/O Error Alert from the CP: The I/O error alert sequence is executed when the CP cannot disable a host interface with an Out X'07' bit 1.7 (set allow channel interface disable). The I/O error alert feature must be present and enabled (out X'02' bit 0.7 = 1).

I/O Error Alert from MOSS: The sequence is executed by the CA when the MOSS raises the 'CA MOSS reset' line and the 'CA nohold' line.

Note: When a CA is enabled from the MOSS console but a HOST connected to the channel hasn't IPLed, the I/O Error Alert sequence may be executed.

Testing and Checking Hardware

The channel adapter contains hardware which allows exercising the checking logic that controls the various error indicators accessible by program with input X'0D', and channel bus checkout which is accessible by inputs X'00' and X'02'.

An imbedded checkout microcode already insures a partial test of the hardware. The checkout result is read via the command 'MOSS in X'4B'. Some functions must be checked by diagnostic program.

Autodiagnosics

Autodiagnosics are routines which are run sequentially whenever the microcode is not processing an interrupt.

If an autodiagnostic routine is interrupted, it will not be resumed at the point of interruption, but the next routine will be interrupted instead. This is to avoid a complex save/restore mechanism.

Functions Provided by Diagnostic Program

Selection Modes

Two selection modes ('concurrent' or 'non-concurrent') are available via the command 'MOSS out X'07'. The difference between these two modes resides in the validation of the commands received over the IOC interface. Interrupt requests for these two modes are routed to the CCU or MOSS, as specified in the definition of command 'MOSS out X'07'.

Channel Wrap Possibilities:

Refer to the *MIP* for test procedures.

Internal Wrap: A wrap possibility (on the CADR card) exists which helps the diagnostics in FRU detection. This may also be used to simulate some channel interface sequences. This function is executed via the command 'MOSS out X'4C'.

External Wrap: This function is executed via the command 'MOSS out X'4C'. Two external wrap connectors must be provided in order to wrap the CAs at the channel tailgate, one to wrap tags-out to tags-in, and one to wrap bus-out to bus-in. The CA tag wrap connector P/N 26F1754, and the bus wrap connector P/N 26F1755 can be used (see Figure 7-8, and Figure 7-9 on page 7-23).

Bus and tag terminators must be plugged in the controller out connectors (light gray). This external wrap possibility is provided only to test the drivers/receivers and tailgate wiring of the channel interface.

CA Interface Wrap Plugs

Tag Wrap Plug P/N 26F1754

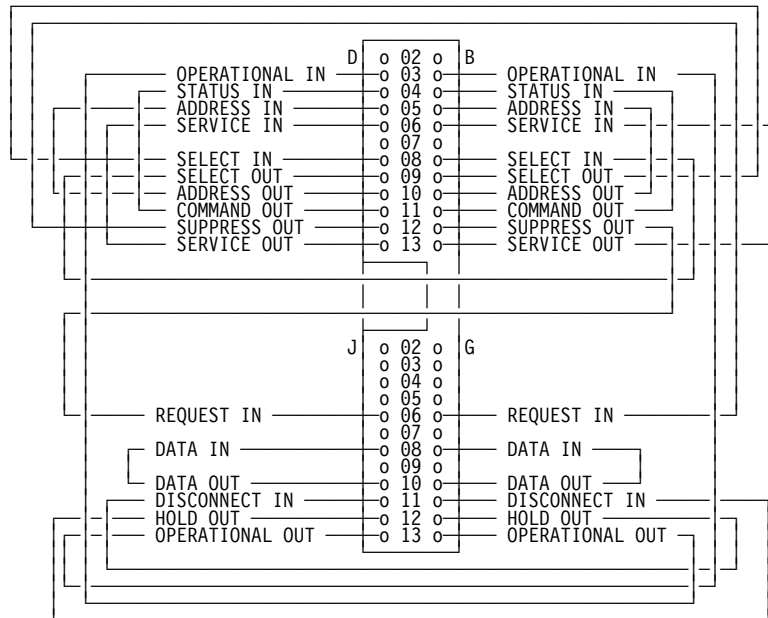

Figure 7-8. Tag Wrap Plug Wiring (P/N 26F1754 - Mating Side)

Bus Wrap Plug P/N 26F1755

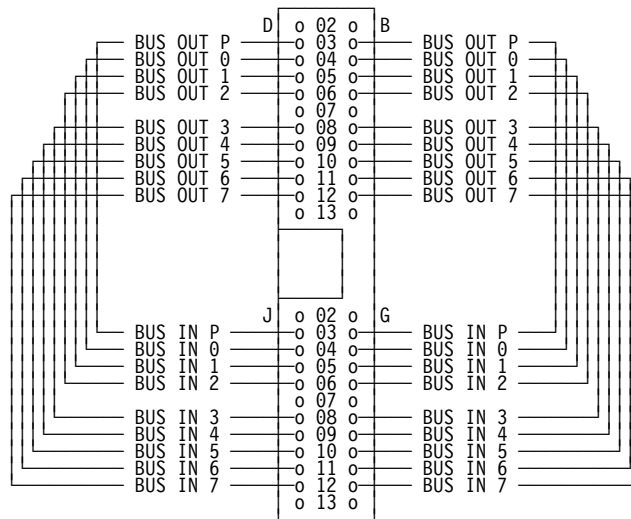

Figure 7-9. Bus Wrap Plug Wiring (P/N 26F1755 - Mating Side)

CA Services

Refer to the *Service Functions*, SY33-2069, for more details.

The command Out X'07' from MOSS with bit 0.2 = 1 is provided to select a specified CA in order to enable CA services from MOSS. This function allows to:

- Display CA status.
- Display interface test points.
- Enter host attachment information at installation time.
- Issue specific commands to the CA, such as:
 - Start/stop trace
 - Dump
 - Display storage and registers
 - Reset
 - Initialization.

CA Interface Display

Refer to the *Advanced Operations Guide*, SA33-0097, for more details.

As soon as the local console is powered ON, the CA interface display screen appears. This screen can also be displayed by selecting the channel interface display (CID) function from MOSS menu 2.

The information displayed is:

- Host attachment information
- NSC address
- MOSS enable/disable request
- Interface status (enabled/disabled).

The CID screen also allows to modify the enable/disable request.

CA Initialization

The CA initialization is performed when a CA receives a POR signal, either at general power ON, or through the MOSS 'Reset' command.

Initialization First Part (Checkout)

At checkout completion, the CA is in the following state:

1. IOC bus interconnection enabled.
2. MOSS interconnection enabled.
3. Host interfaces disabled.

The results of the checkout are available to the MOSS microcode.

Initialization Second Part

This part is performed during IPL phase 1A, or during the 'Restore' CACM command. The MOSS microcode initializes each CA.

Initialization Third Part (Chaining)

Only those CAs that passed the first and second parts of the initialization can be installed in autoselection and cycle steal chains. Chaining process is performed during IPL.

Only when all the CAs are initialized, can the control program start.

Chapter 8. Maintenance and Operator Subsystem (MOSS)

The MOSS in 3745 Models 130, 150, 160, and 170 Data Flow	8-2
The MOSS in 3745 Model 17A Data Flow	8-3
Introduction	8-4
MOSS Processor	8-4
Packaging	8-4
MOSS Reset	8-5
MOSS Functions	8-8
MOSS States	8-9
MOSS Changes of State	8-9
Branch Trace	8-11
Branch Trace Buffer	8-11
Conditional Branch Trace	8-12
Mailbox Description	8-13
Exchange Time Outs	8-13
CCU to MOSS Communication (Out Mailbox)	8-14
MOSS-to-CCU Communication (In Mailbox)	8-14
Mailbox Commands	8-15
LSSD Operation	8-17
Data Flow	8-17
LSSD Testing Circuit	8-17
MOSS/Disk Drive Interaction	8-19
Disk Commands	8-19
Read/Write Operations	8-20
MOSS/Operator Console Connections	8-20
Remote Support Facilities (RSF)	8-20

The MOSS in 3745 Models 130, 150, 160, and 170 Data Flow

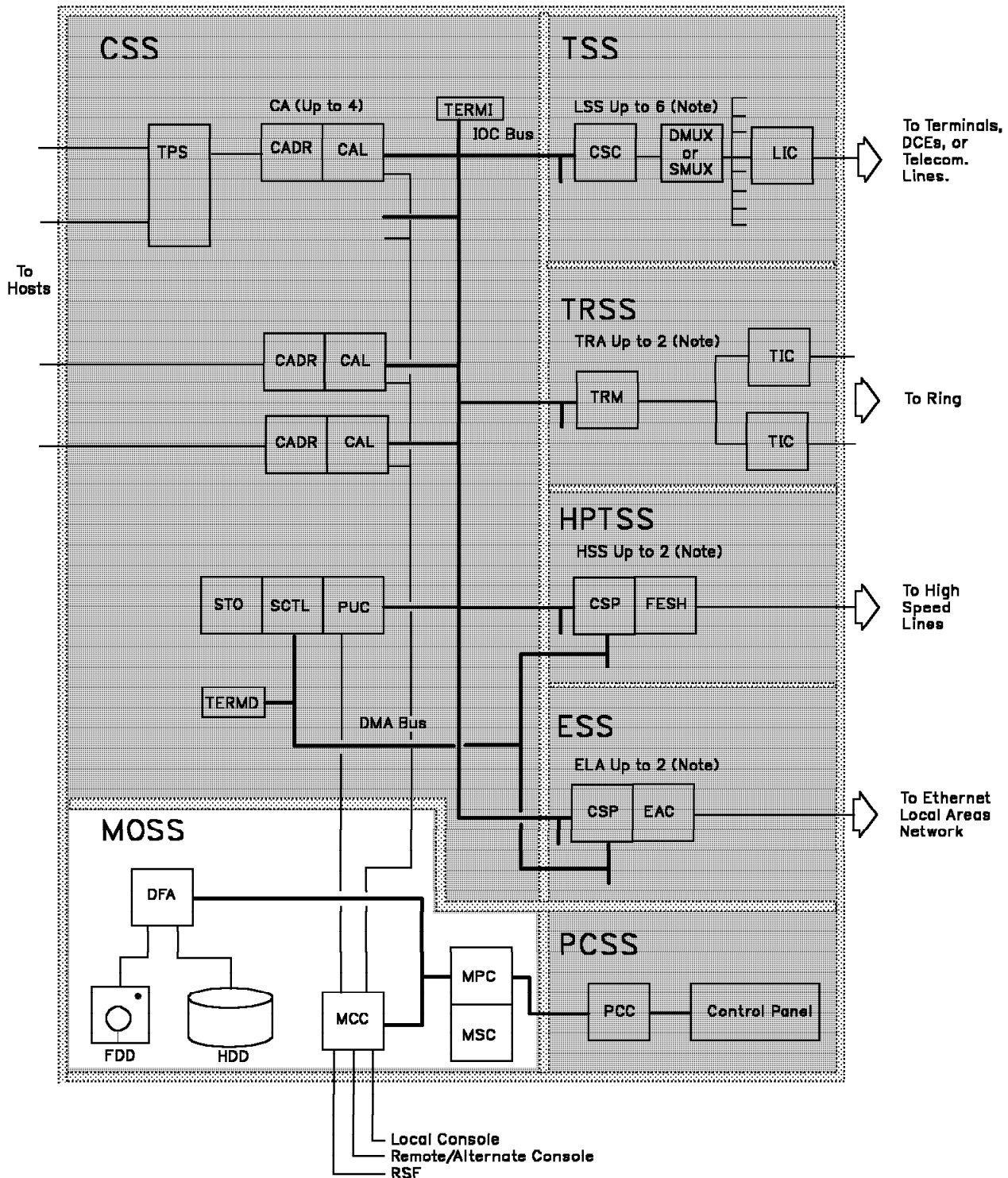

(Note) The number of LSS+HSS+ELA does not exceed 6

The MOSS in 3745 Model 17A Data Flow

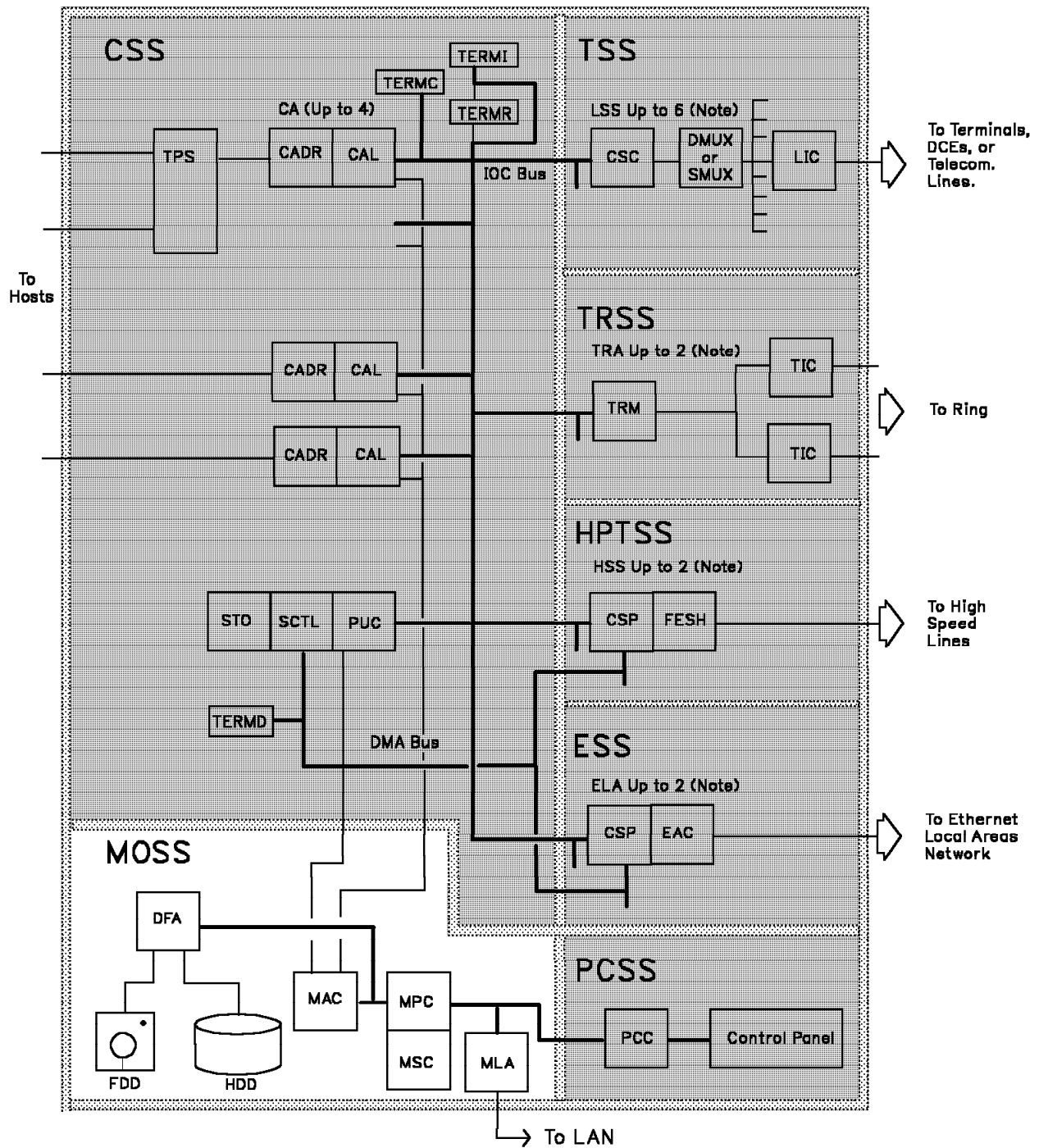

Figure 8-1. The MOSS in 3745 Model 17A Data Flow. For model 17A, DMA and IOC buses are connected to the CBC in the 3746-900. This MLA card links the MOSS to the Service Processor through a LAN.

Introduction

MOSS is the service processor of the communication controller. It performs IPL functions, machine initialization, and provides the operator with tools for problem determination.

The 3745 Model 130/150/160/170/17A MOSS is based on a microprocessor which controls a 2MB main storage, the MIOC buses, the channel adapters, the disks (hard disk and flexible disk), the consoles (local, remote/alternate, and RSF) on model 1x0 or a service processor on model 17A.

MOSS interconnects with the power control card which drives the control panel. The MOSS logic, the flexible disk drive, and the hard disk drive are powered by a specific power supply, so that removing power from the MOSS board does not impair the operation of the system.

On 3745 Model 17A, the MLA card links the MOSS to the service processor via the LAN. The MLA card interfaces to the MOSS processor (MPC card) via the MMIO bus.

MOSS Processor

The MOSS processor drives the MOSS. It has its own instruction set, and does the usual processing activities: instruction fetching, instruction decoding, and instruction execution.

The MOSS processor responds to interrupts from the CCU, from its attached adapters (LAs, CAs), and from its own error detection circuits. It controls access to the MOSS storage. The MOSS processor is packaged on the MPC card.

Packaging

Refer to Figure 8-3 on page 8-6 for MOSS structure on 3745 Models 130-170 and to Figure 8-4 on page 8-7 for MOSS structure on 3745 Model 17A. The MOSS board includes:

- A MOSS processor card (MPC) with a 32-KB ROS, a time-of-day (TOD) clock, a storage error correction and checking circuit. The MPC card connects UC buses, the MSC card and the power control card (PCC).

Note: Each time that the MOSS is reset, a led is lit on the MPC card. This led is turned OFF by the ROS microcode when the connection with the PCC card is established.

- A 1-MB RAM MOSS storage card (MSC) on 3745 Models 130-170 or a 2-MB RAM MOSS storage card on 3745 Model 17A.
- A power control card (PCC), which interconnects the MOSS control panel to the MPC card. The PCC card is powered by PS2 in the primary power box, in order to allow the remote power function, and manages the whole power control subsystem (see Chapter 10 for details).
- On models 1x0, a MOSS and console adapter card (MCC) containing:
 - One adapter module for CCU bus

- One adapter module for 4 channel adapters
 - Three console adapter modules providing three ports for:
 - A local console
 - A remote/alternate console
 - An RSF modem
 - One oscillator, and drivers/receivers (EIA V.28/RS-232-C).
 - On model 17A, a MOSS adapter card (MAC) containing:
 - One adapter module for CCU bus
 - One adapter module for 4 channel adapters
- On 3745 Model 17A, a MOSS LAN adapter card (MLA) which links the MOSS to the service processor through the LAN.
- A disk file adapter card to attach:
 - One flexible disk drive (FDD),
 - One hard disk drive (HDD).

Note: See pages YZ-031 for MOSS card and connector locations, and pages YZ-331 for test points.

MOSS Reset

When a MOSS reset occurs, the led on the top of the MPC card is turned ON. The panel displays code 001, a read MMIO bus is started by the MOSS code. If the result is good, the led is turned OFF and the display code goes to 002. If the result is not good after a two-second time out, the led starts blinking.

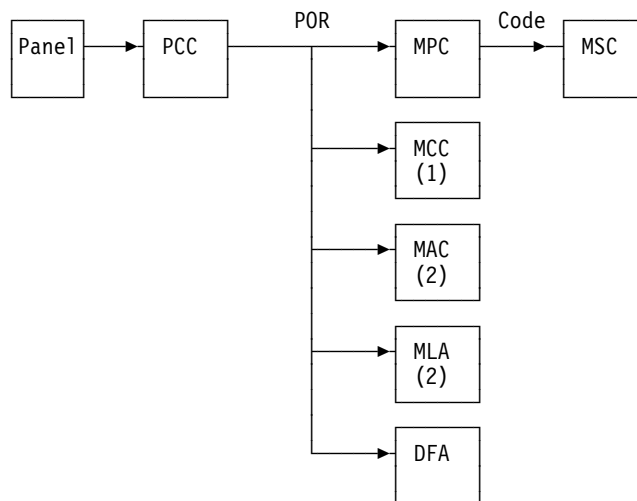

(1) = On 3745 Models 1x0
 (2) = On 3745 Model 17A

Figure 8-2. MOSS POR Flowchart

- MPC reset consists of terminating the operation in progress and initializing internal registers. The reset sequence does not initialize main storage, or register space. Those are initialized by storing into them with good parity. Several specific control areas are also initialized by the IML program.
- A MOSS reset ONLY is performed with *Function* = 1 (MOSS IML) at the control panel.

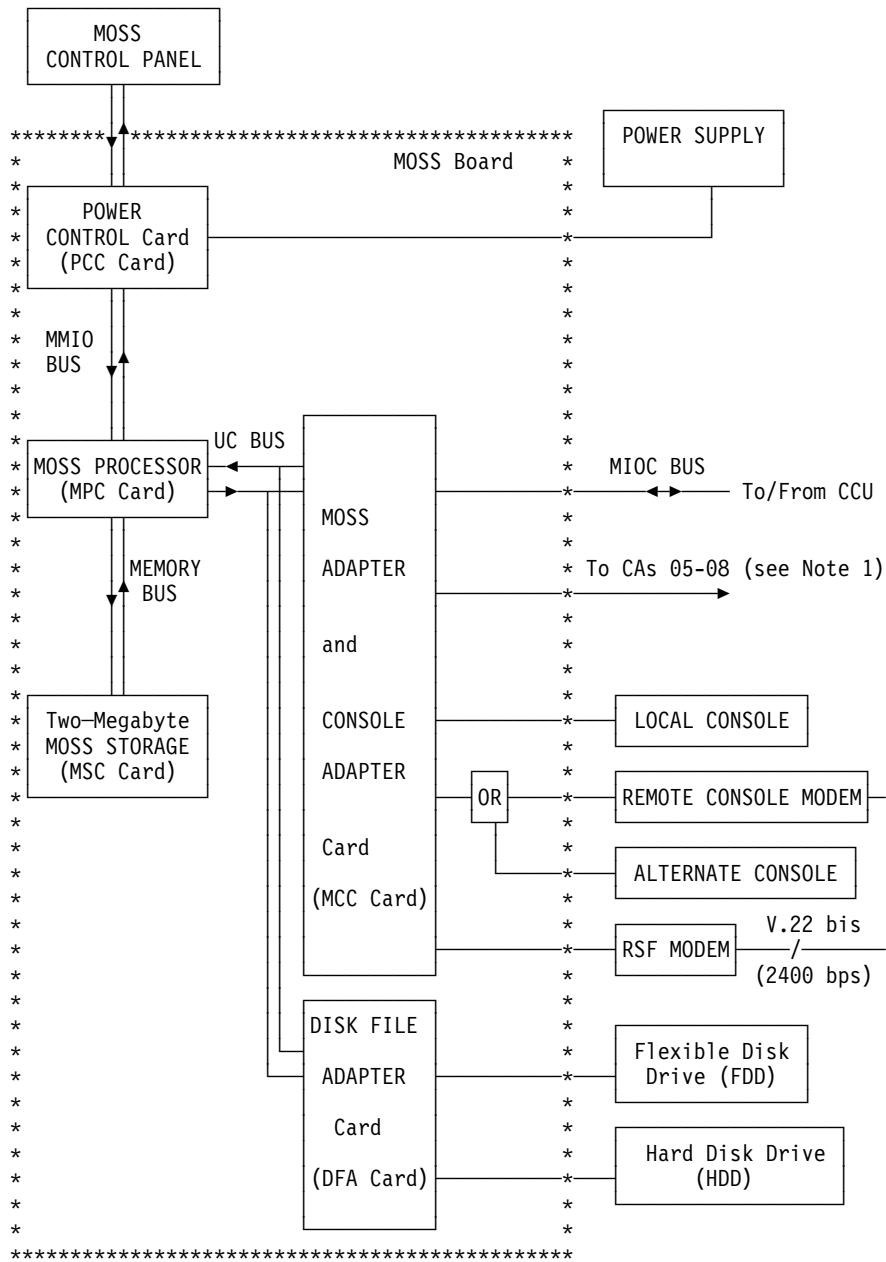

Figure 8-3. MOSS Structure on 3745 Models 1x0

Note 1: 'To CAs 05-08' is a control line that allows enabling/disabling or resetting the CAs.

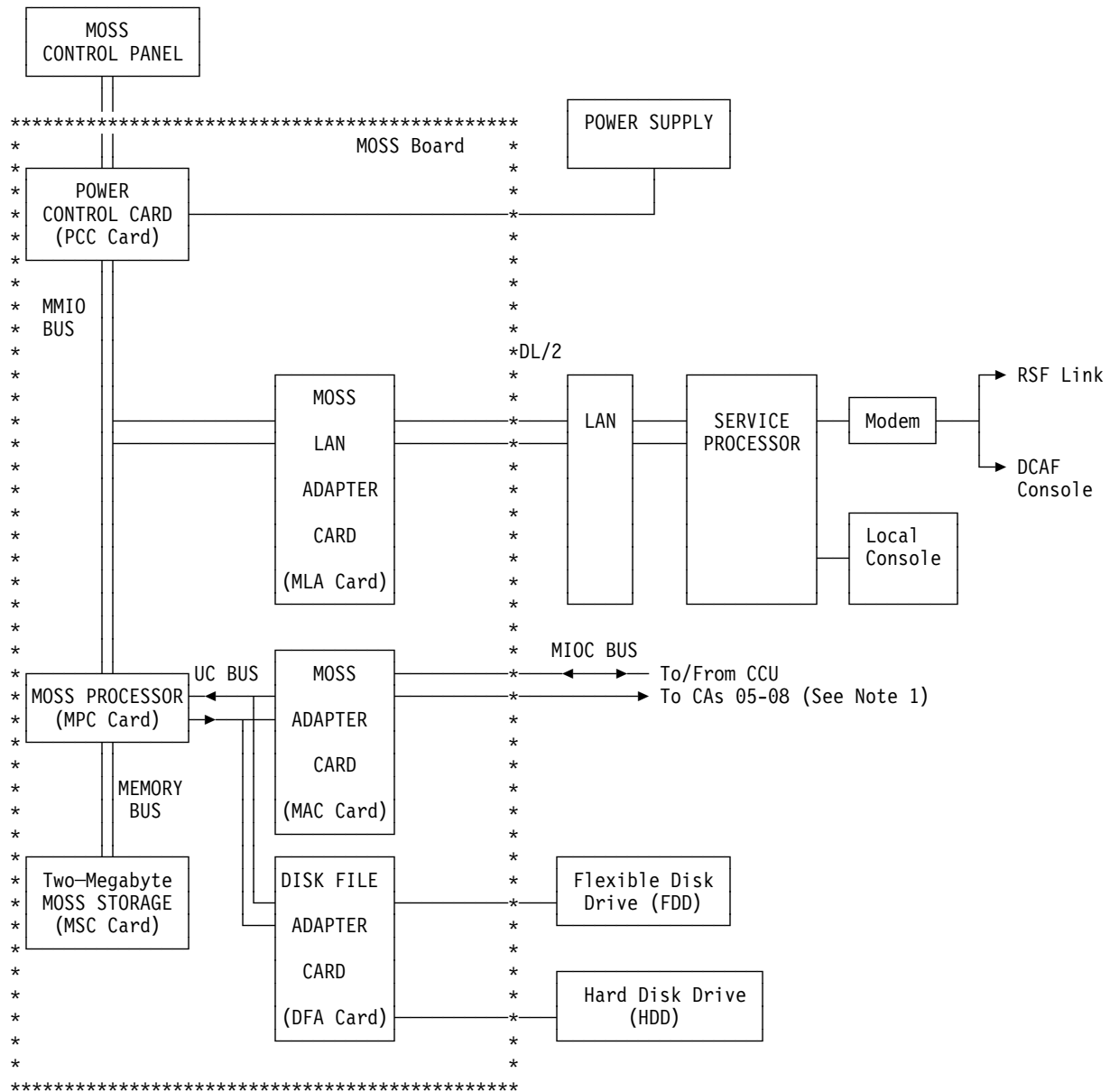

Figure 8-4. MOSS Structure on 3745 Model 17A

Note 1: 'To CAs 05-08' is a control line that allows enabling/disabling or resetting the CAs.

MOSS Functions

The maintenance and operator subsystem (MOSS) provides access to the 3745 and makes the following components easier to maintain:

- Control program (NCP, PEP).
- Central control unit (CCU).
- Channel adapters (CA).
- Line adapters (TSS, HPTSS, TRSS, ESS, and LA microcode).
- Line interface cards (LICs/TICs).
- The MOSS processor itself, its microcode, and the I/O adapters used to attach the control panel, the consoles, the flexible and hard disk drives, the CCU, and the channel controls.

Using the MOSS, the service personnel can:

1. Initialize the 3745 with:
 - Standalone IPL from disk
 - Hardware checkout diagnostics
 - IML/IPL from the control panel or the console
 - CCU IPL
 - Line adapter IML.
2. Maintain the 3745 with:
 - Remote support facility (RSF) for 3745 Models 1x0.
 - Concurrent diagnostics.
 - LIC hot plugging
 - Box event handling (error recording, analysis and display, alert/alarm generation)
 - Line services (line wrap tests, line interface display, token-ring interface display, ESS interface display)
 - CCU control program procedures
 - Machine history files: configuration data file (CDF), machine level table (MLT), IPL port table
 - Password management for 3745 Models 1x0
 - Microcode utilities (dumps and file transfer to host, MCF, RECFMS)
 - CA control/status display from the console
 - Machine status area display.
3. Use 3745 services such as:
 - CCU services
 - TSS services
 - TRSS services
 - CA services
 - Power services
 - Time services.

MOSS States

Some states are viewed by the NCP or PEP (DOWN, OFFLINE, ONLINE). Other states exist when the NCP or PEP is not loaded in the CCU (DOWN, ALONE).

- **MOSS DOWN** indicates that no program is running in the MOSS or that MOSS IML is in progress. In this state the 'MOSS Inoperative' line is up and the CCU interface is disabled.
- **MOSS ALONE** indicates that the MOSS microcode is loaded and operational (CP not loaded).
- **MOSS OFFLINE** indicates that the MOSS microcode is running in the MOSS, but that communication cannot be established with the NCP/PEP (except for exchange with CLDP, and NCP/PEP initialization, which are part of the 3745 system IPL). In this state, the CCU is enabled.
- **MOSS ONLINE** indicates that the MOSS microcode is running and allows communications with the NCP/PEP. In this state, the CCU interface is enabled.

(Numbers refer to the steps of "MOSS Changes of State")

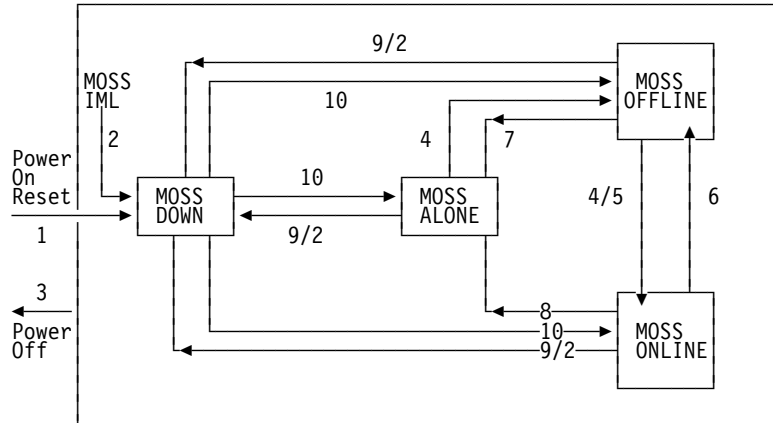

Figure 8-5. MOSS Changes of State

MOSS Changes of State

The following is a description of the events and actions that cause a MOSS state change. Step numbers identify events and actions in Figure 8-5.

Step 1. POWER ON RESET, according to panel option:

- Panel option = MOSS IML ('Function' = 1). The MOSS DOWN state is entered during the time MOSS IML is performed, then MOSS ALONE [10] is entered and is kept until further action.
- Panel option = NORMAL or DISKETTE MODE. The MOSS DOWN state is entered during the time MOSS IML is performed, then MOSS ALONE [10] is entered, then MOSS OFFLINE [4], then MOSS ONLINE [5]. This is the full system IPL.

Step 2. MOSS IML request at panel (Function = 1). The same sequence occurs as in step 1 above, according to the panel option.

Step 3. POWER OFF. The full system leaves its current state.

- Step 4.
- A NORMAL IPL has been requested, [1] or [2].
 - 3745 IPL has been requested from the console menu.
- Step 5.
- A NORMAL IPL has been requested, [1] or [2].
 - 3745 IPL has been requested from the console menu.
 - The MOSS operator enters a MOSS ONLINE command from the console to exit from the OFFLINE MODE.
- Step 6.
- The MOSS operator enters a console MOSS OFFLINE command.
 - In case of hardware error on the MOSS/CCU interface during the processing of a mailbox.
 - In case of a time out occurring while processing exchanges from the NCP.
- Step 7.
- During a NORMAL IPL the process aborts and cannot be completed successfully.
 - A channel or program IPL request is presented to MOSS.
 - A CCU hard check is presented to MOSS.
- Step 8.
- A channel or program IPL request is presented to MOSS.
 - A CCU hard check is presented to MOSS.
- Step 9.
- A MOSS abend occurred.
 - START panel request while the MOSS was in the OFFLINE, ONLINE, or ALONE state.
 - IML command entered at the console.
- Step 10.
- If the reason to enter the MOSS DOWN state was an abend or an IML command entered at the console, after MOSS re-IML the final state is the one which was interrupted by the abend.
 - If the reason to enter the MOSS DOWN state was a START panel request or an IML command entered at the console, after MOSS re-IML the final state depends on the function option selected. In case of START IML MOSS, the final state is the same as the one which was interrupted, except for MOSS ONLINE which is forced to MOSS OFFLINE.

Branch Trace

The branch trace facility allows the CCU hardware to record the non-sequential operations occurring in the flow of the CCU control program, into a predefined buffer.

Any time a branch actually occurs in the CCU, the 'come from' and the 'go to' addresses are stored into the buffer, as well as the corresponding 'come from' and 'go to' program level(s).

A non-sequential operation takes place when:

- A conditional or unconditional branch instruction is executed.
- An instruction modifies the instruction address register (reg 0 of the active program level).
- A new program level is entered, due either to a program control interrupt issued by the CCU control program, or to an external interrupt caused by any adapter, or to an EXIT instruction.

When requested, the MOSS loads the branch trace registers with the upper and lower branch trace limits, and with the branch trace table definition (address in main storage and length). The branch trace registers are located in CCU local storage.

The MOSS then requests the CCU to record the 'come from' and 'go to' information of any actual branch in the branch trace buffer.

The branch trace information is stored in two contiguous storage positions as follows:

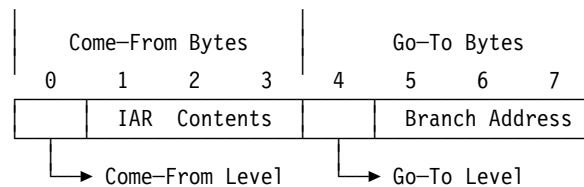

Branch Trace Buffer

The branch trace buffer allocation is made at Control Program generation time, by providing the buffer starting address and the buffer length as system generation parameters. When IPL is performed on the CCU, the buffer allocation values are passed over to MOSS.

The MOSS defines the branch trace buffer with MOSS Write LS (indirect operations). When the buffer is full, either the CCU is stopped and the MOSS is interrupted, or the MOSS only is interrupted.

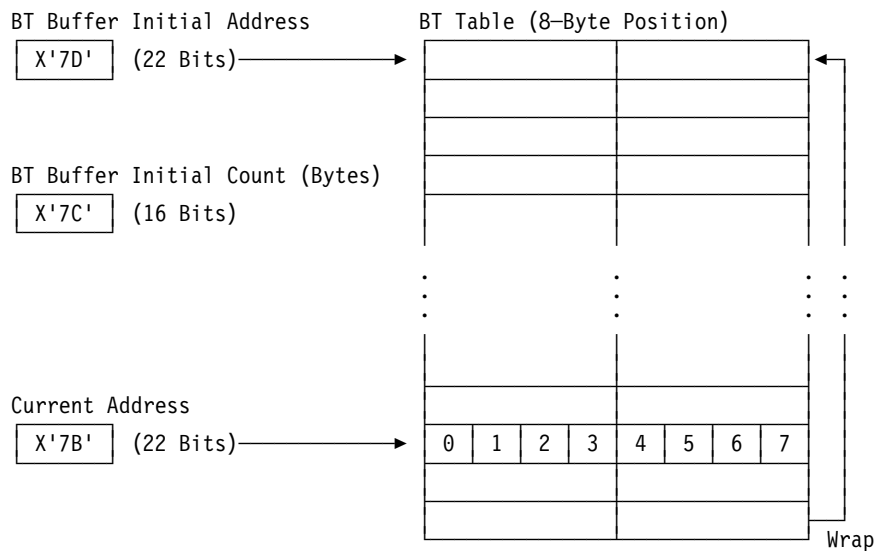

Figure 8-6. Branch Trace Buffer

If wrap is specified, 'branch trace buffer full' causes the branch trace count to be reinitialized, and the branch information to overlay the start of the branch trace buffer.

Under certain circumstances, the branch trace buffer may contain extra records showing the entry and the exit of the CCU through some program level, without instruction execution at that level.

Conditional Branch Trace

The conditional branch trace allows to start and stop a branch trace from the control program itself without MOSS intervention. The branch trace default values are initialized by MOSS at IPL time.

In order to avoid contention between MOSS and CP requests with different options, starting a branch trace is inhibited if there is one already active.

Mailbox Description

The NCP/PEP and the MOSS communicate through CCU storage areas called mailboxes. These mailboxes are located in the 32-KB area reserved for MOSS use, at the top of CCU main storage (see Table 8-1).

CCU Storage (32K Top Area)	Address in 4MB Storage
Spare (192 bytes)	X'3FFFFFF' X'3FFF40'
NCP Out Mailboxes (32 bytes)	X'3FFF3F' X'3FFF20'
NCP In Mailboxes (32 bytes)	X'3FFF1F' X'3FFF00'
Unused	X'3FFEFF' X'3FA400'
MOSS to Line Adapter Data Area (8704 bytes)	X'3FA3FF' X'3F8200'
Line Adapter Mailboxes (512 bytes)	X'3F81FF' X'3F8000'
Top of Non-Reserved Storage	X'3F7FFF'

For a detailed description of the mailbox contents, see the *3745 Principles of Operation*, GA33-0102.

Exchange Time Outs

The requestor fills in his mailbox and posts an interrupt to the receiver. The receiver grants the interrupt, decodes the mailbox contents, posts a status in the mailbox, and interrupts the requestor. Throughout this time, the mailbox is busy with the requestor. A timer is used to provide a protection against requests that are not answered.

On the NCP side, if a time out occurs, the MOSS is considered down and an alert is sent to the host.

On the MOSS side, if a time out occurs, a return code is passed to the requesting application to signal this situation. In this case, the NCP/PEP is probably down and operator intervention may be required.

CCU to MOSS Communication (Out Mailbox)

The out mailbox is used to pass requests from the NCP/PEP to the MOSS and for the MOSS to post the status response.

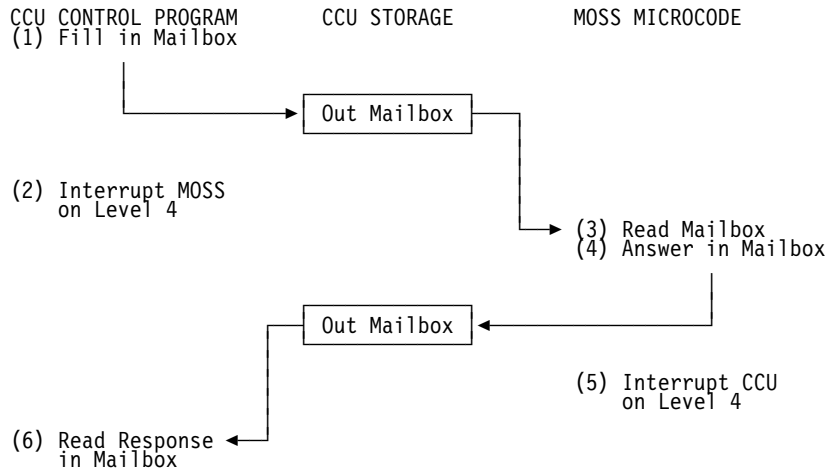

Figure 8-7. Out Mailbox Exchange Procedure

MOSS-to-CCU Communication (In Mailbox)

The in mailbox is used to pass MOSS requests to the NCP/PEP and for the NCP/PEP to post the status response.

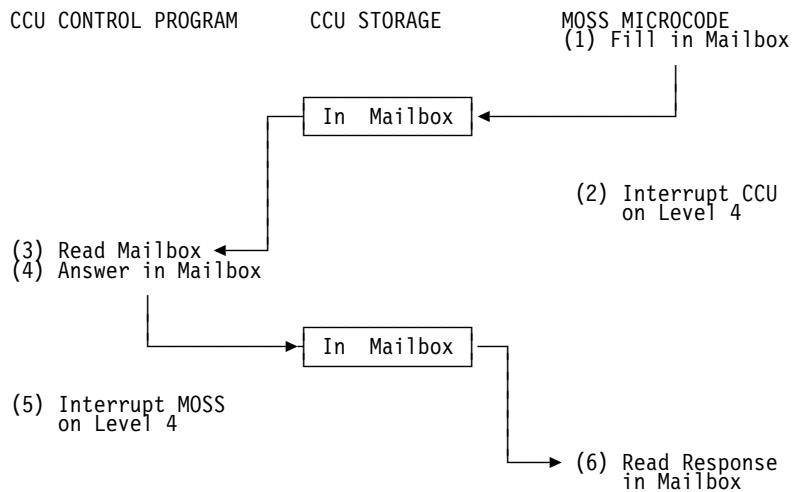

Figure 8-8. In Mailbox Exchange Procedure

Mailbox Commands

The following table (Table 8-2) shows the commands sent by the MOSS to the CCU control program (IN mailboxes), and in which functions they are involved.

<i>Table 8-2. NCP Mailbox In Commands</i>		
Function	Hex	In Command
CLDP	C1 C2 C3 C4 C5	Line adapter IML complete Roll in complete IPL from disk complete Control information response Dump records saved
Initialization	A3 A4 B2	CP parameter saved CDS information available Reissue port swap
Normal	86 89 8A 8C 8D 8E 8F 90 91 92	Transfer PIU: <ul style="list-style-type: none"> • Solicited response • Unsolicited reply • Dump storage response Wrap test request Stop wrap test Connect line adapter Reissue a 3746-900 port swap Request buffer Free buffer MOSS offline MOSS online Port swapped
Reconfiguration	84	Update CDS 01: Delete ports, 02: Add ports 03: Delete line, 04: Add line 05: Change CDS header 06: Insert CA, 07: Delete CA, 08: Change CA
CA Services	93 94 95 96	Disconnect CA Connect CA 01: Initialize procedure 02: Cancel procedure AS/SC chain update 01: Remove CA from AS chain 02: Remove CA from CS chain 03: Insert CA into AS chain 04: Insert CA into CS chain Install CA 01: Start INSTALL procedure 02: Cancel INSTALL procedure

The following table (Table 8-3) shows the commands sent by the CCU control program to the MOSS (OUT mailboxes), and in which functions they are involved.

Function	Hex	Out Command
CLDP	41	CP loaded
	42	Roll in saved storage
	43	IPL from disk
	44	Control information
	45	Dump records built
Initialization	23	CP parameter
	24	Request hardware CDS
	25	CP initialization complete
	26	Request hardware CDS (swap)
	27	Request reissue port swap
Normal	06	Transfer PIU:
	07	The PIUs processed by MOSS are listed
	08	in Table 8-4.
	09	NCP/PEP BER transfer
	0C	Buffers now available
		Wrap test results
		Time/date valid
0D	Request a 3746-900 port swap	

Request Unit List

Request unit (RU) sent by SSCP and processed by the MOSS.

Hex	Meaning
010331	Display storage, answered by : 010334 record storage
410304	REQMS, answered by : 010334 RECFMS REQMS = Request of maintenance statistics RECFMS= Record formatted of maintenance statistics
010203	IPL Init (see note)
010204	IPL Text (see note)
010205	IPL Final (see note)
010206	Dump Init (see note)

Note: Answered by a positive response or a sense code when negative response. Refer to the Sense Code Appendix in the AOG.

LSSD Operation

Level sensitive scan design (LSSD) operations are powerful diagnostic tools used especially during IML, or when running CCU diagnostics.

LSSD datas are kept in the file CDF. They can be displayed with the CDF file.

In LSSD operations, the MOSS can verify or change the status of any discrete CCU latch. Such operations can be performed after any CCU cycle, by stopping the CCU clock.

Data Flow

Figure 8-9 on page 8-18 is a simplified representation of the data flow. Normally, the complete CCU can be represented with 12 strings each having an average of 100 SRL statuses.

The 'SRL out' lines present their status to the following combinational logic at clock pulse B. The resulting combinational logic values set the 'SRL In' lines at the next clock pulse C.

LSSD Testing Circuit

For testing purposes, the above 'SRL Out' are connected to 'SRL In' lines in a sequential string as follows (Figure 8-10 on page 8-18). The 'In' and 'Out' lines go to their combinational logics. 'Scan In' is the string input; 'Scan Out' is the string output.

With LSSD operations the MOSS can:

1. Read the CCU SRLs for diagnostic purposes ('scan out' to MOSS scan register).
2. Set/reset the CCU SRLs to a preset value for initial CCU reset (scan register to 'scan in').

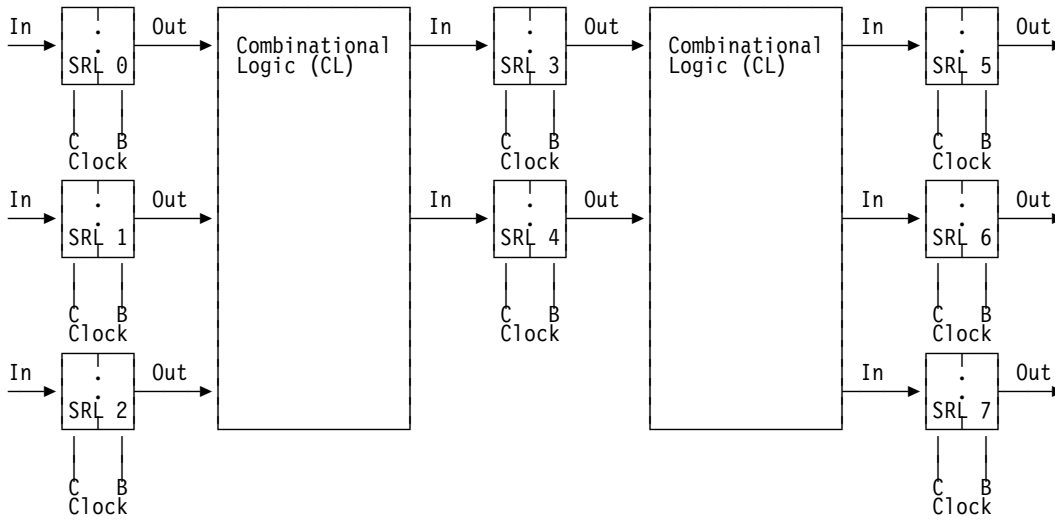

Figure 8-9. Simplified Data Flow

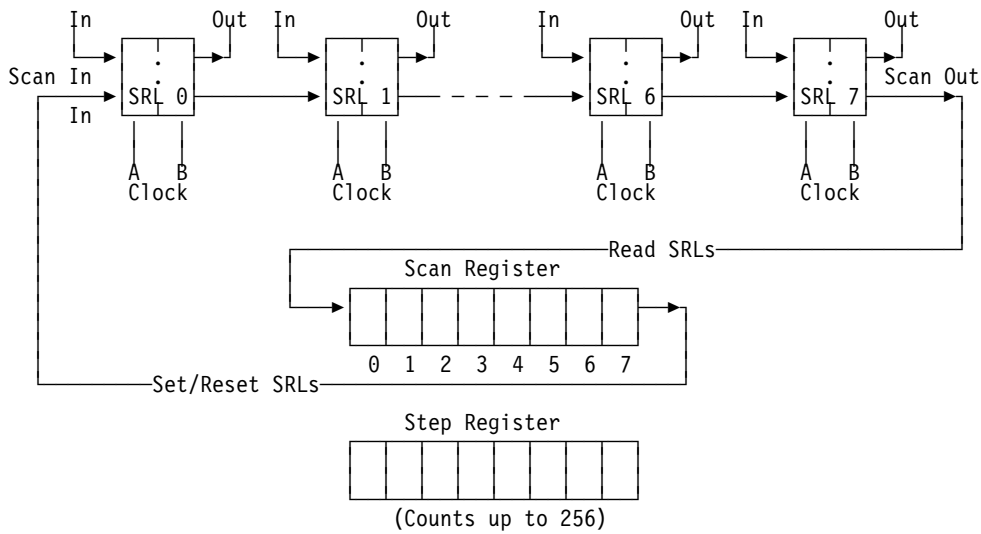

Figure 8-10. LSSD Testing Circuit

MOSS/Disk Drive Interaction

The hard/flexible disk drives are described in Chapter 9 of this manual.

Disk Commands

The MOSS processor controls the disk file adapter (DFA) and its attached drives via program or channel I/O commands on the MOSS external UC bus. These commands allow the MOSS to:

1. Start or stop the flexible and hard disk drives.

Notes:

- DC voltages to disk drives are stopped when there is no activity on disks for 15 minutes (see "Disk and Diskette Drive On/Off Control" in Chapter 9 for details).
- There are three lines READY, INDEX, and TRACK0 which are common to both the HHD and the FDD. READY line is doted on the MOSS board; INDEX and TRACK0 are doted on the DFA card.

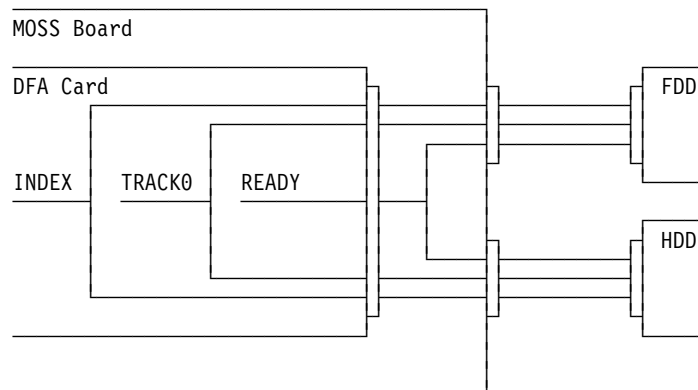

2. Set or sense the file adapter registers.
3. Seek head carriage.
4. Engage the heads (position the heads close to the disk/diskette surface).
5. Read data from the disk/diskette.
6. Write data to the disk/diskette.
7. Read back the data for checking purposes.

The DFA rejects commands that are invalid, or have a bad parity. A command that temporarily cannot be serviced by the disk/diskette drive is considered invalid.

The command is not retried. It causes a machine check/program check end status indication.

Read/Write Operations

Read or write operations are initiated via PIO commands. Data is exchanged directly with the MOSS storage through the DFA. (Halfword cycle stealing operation.)

MOSS/Operator Console Connections

The operator consoles can be attached to the processor via the MCC card. The MOSS can control only one console at a time.

Chapter 9 of this manual gives details on operator consoles themselves, and the *3745 Models 130/150/160/170 Service Functions*, SY33-2069, describes how the service functions are used from the 3745 console.

For console connections and operations on 3745 Model 17A, refer to *3746 Model 900 Installation Guide and Service Processor Installation and Maintenance* manuals.

Remote Support Facilities (RSF)

The MOSS-to-RETAIN connection is made with a BSC protocol at 1200/2400 bps (V.22 Bis or V.23 CCITT interface, depending on the country), via a duplex external modem with the auto-answer feature.

The IBM RSF Modem operating characteristics are as follows:

- Connection over a switched line
- Duplex transmission
- Synchronous transmission
- Auto-answer feature
- Transmission speed: 1200/2400 bps
- Clocking by the modem clock
- DSR control by the modem

For remote support facilities on 3745 Model 17A, refer to *Service Processor Installation and Maintenance* manual.

Chapter 9. Control Panel, Operator Consoles, Disk/Diskette Drives

Control Panel	9-2
Overview	9-2
Control Panel Layout	9-3
Control Panel Connection	9-5
Control Panel Operation	9-5
Operator Consoles for Models 1x0	9-6
Highlights	9-6
Console Connection	9-8
3161 Console 3727 Console Key Conversion	9-8
Console Setup and Maintenance	9-8
Operator Consoles and Service Processor for Model 17A	9-8
Disk/Diskette Drive	9-9
Hard Disk Drive (HDD)	9-9
Flexible Disk Drive (FDD)	9-10

Control Panel

Overview

For 3746-900 control panel, refer to:

- The 3746 Model 900 HMR (online document) for detailed information.
- The MIP for details on the control panel functions.

The 3745 control panel consists of:

- A ten-digit alphanumeric display
- A key pad with seven keys
- A unit emergency power OFF switch
- An overlay corresponding to national language requirements
- A power ON lamp.

See "Control Panel Layout" on page 9-3 for details.

The control panel carries keys and indicators required for:

- Controlling the power system
- Activating MOSS functions, control panel test, power bus test
- Hexadecimal display code to operator.

The 3745 control panel stays powered ON when the 3745 is powered OFF. This allows information on power control and service to be displayed.

The 'Function', 'Service' and 'Power control' keys allow the operator to scroll the different options. The option is performed by pressing the 'Validate' key, or cancelled by pressing the 'Exit' key. Refer to the *Basic Operations Guide* for more details on the control panel functions.

Control Panel Layout

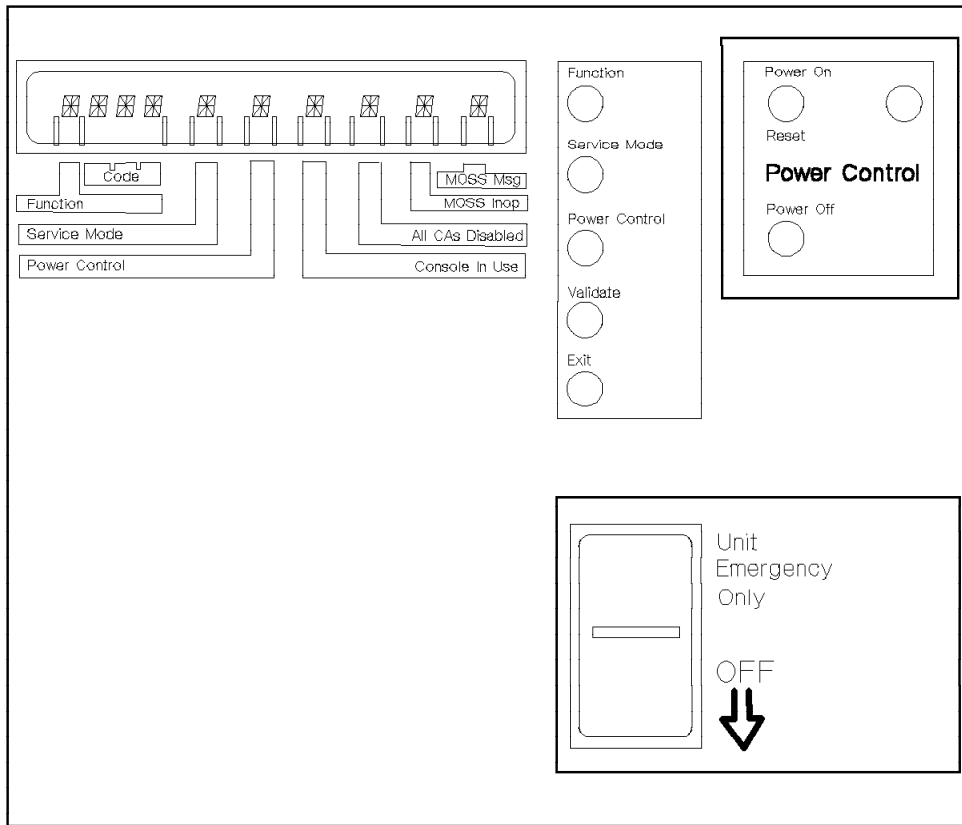

(*) For code definitions, refer to Appendix A in the *MIP*.

Figure 9-1. Control Panel

Control Panel Reference Card

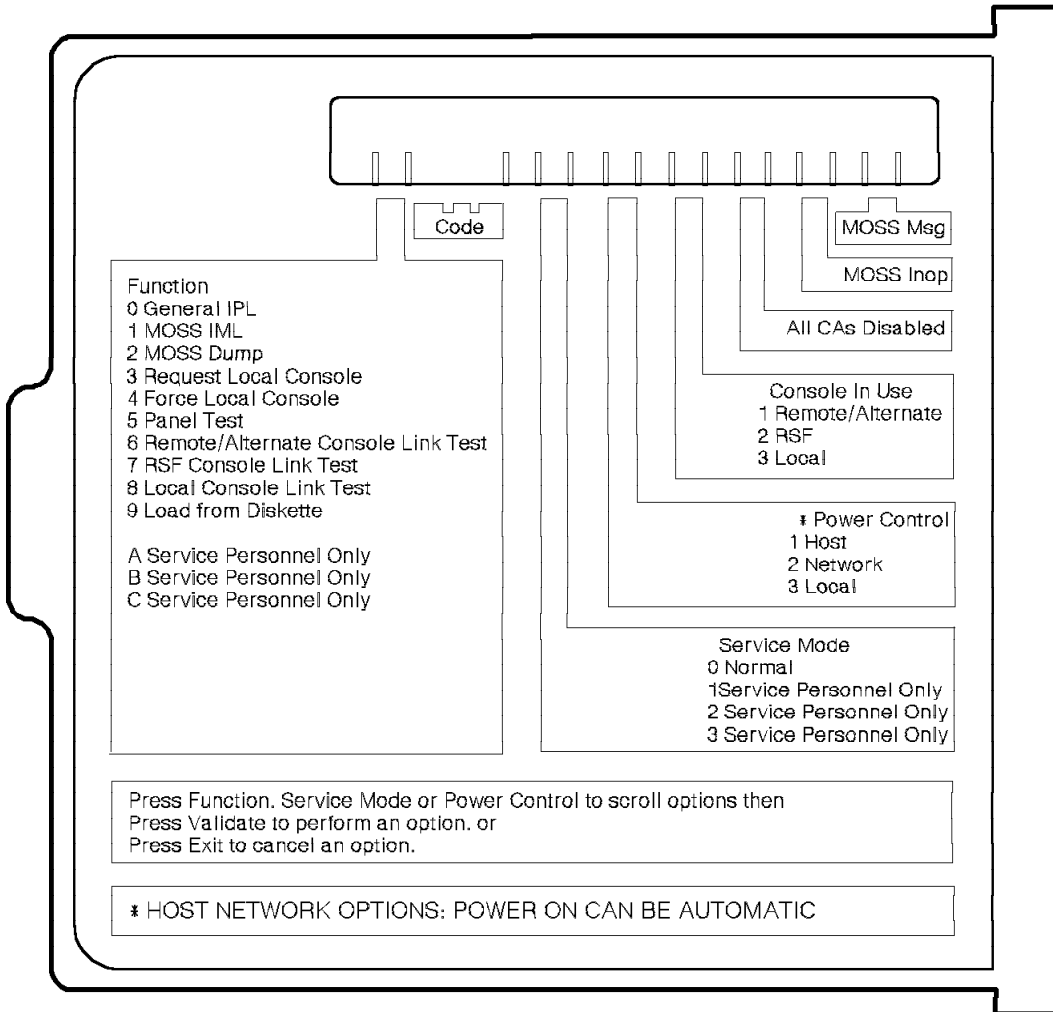

Figure 9-2. Control Panel Reference Card

Control Panel Connection

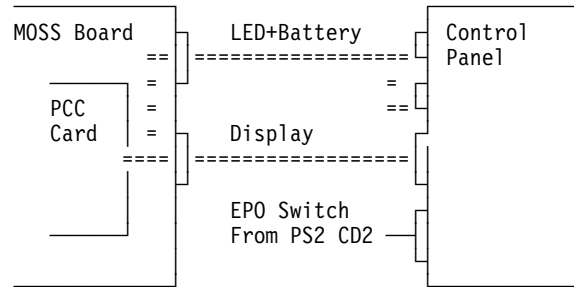
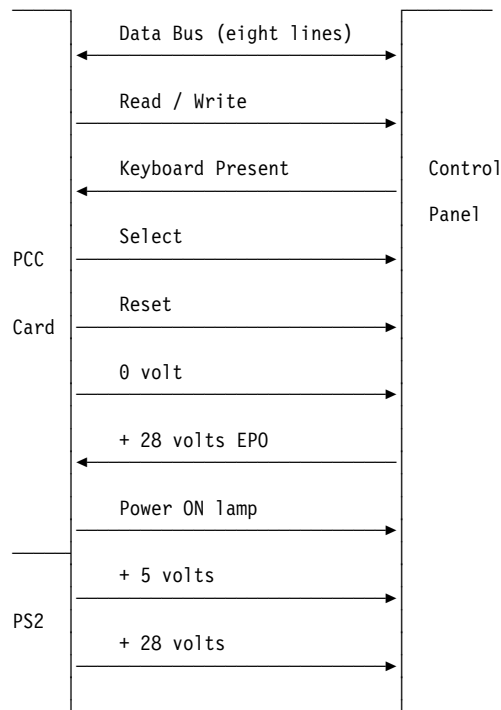

Figure 9-3. Control Panel Connection

For component locations on MOSS board and control panel, see YZ pages.



Control Panel Operation

For control panel operation and tests, refer to *Basic Operations Guide* and *MIP*.

Operator Consoles for Models 1x0

Highlights

The 3745 offers three different console interfaces. Activation of these attachments are under MOSS control via the MCC card. Only one of these attachments may be active at a time.

The consoles whose characteristics are listed below are used either by the customer or by IBM service personnel.

For more details on console configuration, see *Console Setup Guide SA33-0158*.

Local Console and Alternate Console

The local console, which is mandatory, and the alternate console operate with interface CCITT V.24 in duplex start-stop mode at 2400 bps.

- IBM 315x Model 110, 160, 310, 360, 410 or 460 Display Station in native mode or in IBM 3101 emulation mode.
- IBM 316x Display Station Model 11, 12, 21 or 22 in IBM 3101 emulation mode.
- IBM 3727 Display Station (keyboard overlay provided in shipping group).
- IBM PS/2* able to run under OS/2* extended edition with Communication Manager emulating the 3101.
- Any equipment providing equivalent functions operating in IBM 3101 emulation mode.

For details about the consoles to be used on the 3745, refer to the *Console Setup Guide SA33-0158*.

Remote Console

Operates in duplex start-stop mode at 1200 bps.

- IBM 315x (in the USA and Canada only, and only if an IBM 5841, 5842, or 5853 modem for USA or 5853 modem for Canada is used at the 3745 end) in native mode.
- IBM 316x Display Station Model 11, 12, 21 or 22 in IBM 3101 emulation mode.
- IBM PS/2 able to run under OS/2 extended edition, with Communication Manager emulating the 3101.
- IBM PC in IBM 3101 emulation mode.
- Any equivalent equipment emulating the IBM 3101 and having an interface CCITT V.24, (EIA 232D).

For details about the consoles to be used on the 3745, refer to the *Console Setup Guide*.

Console Sharing Via IBM 7427

The IBM 7427 Console Switching Unit can be used with the 3745 for 31XX and 3727 consoles.

A maximum of four communication controllers can share a local console.
A maximum of six communication controllers can share an alternate console.

Remote Support Facility (RSF)

Attached to the 3745 over the public switched network via a modem.

For details, see page 8-20.

Consoles Tail Gate on Models 1X0

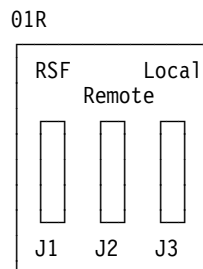

- The J1 connector is for the RSF console.
- The J2 connector is for the remote or alternate console.
- The J3 connector is for the local console.

See YZ pages for details.

For 3745 Model 17A

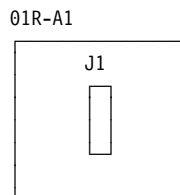

The J1 connector is for service processor connection through the LAN.

Customer Power Control

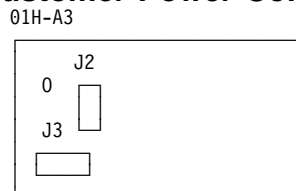

The J2 connector is for the customer and provides a normal-open contact when the power is OFF, and reverse its state when the power is ON.

Electrical Characteristic:
30 volts AC or 42.4 volts peak or DC at 20 to 500 mA.

For details, see page YZ560.

Console Connection

For console connection, cable wiring, cable length, and cable part number, see *IBM External Cable References* manual, SY33-2075.

3161 Console 3727 Console Key Conversion

3161	3727
BREAK	ATTN
PF1	SELN AREA
PF2	CCU FNCTN
PF3	MSG
PF4	PF1
PF5	PF2
PF6	PF3
PF7	PF4
PF8	PF5

Adhesive keytop labels part number = 03F7773

Console Setup and Maintenance

See appropriate console documentation.

Operator Consoles and Service Processor for Model 17A

To operate and maintain the 3745-17A and 3746-900 a new operator console is required. The 3745/3746-900 operator console is a PS/2 based console fully configured and loaded with microcode called MOSS extended (MOSS-E). The operator console serves as service processor to the 3746-900 and the 3745 and must always be powered On. The console can operate up to four 3745 Models 17A to 61A but with a maximum of two of them equipped with a 3746-900.

For more details on operator console configurations and installation refer to the "Operator and Service Processor" chapter in the *3746 Model 900 Hardware Maintenance Reference*, online documentation and the *3745 Models 130 to 17A and 3746 Model 900 Installation Guide*, SY33-2067.

Disk/Diskette Drive

Hard Disk Drive (HDD)

Description

The 3745 hard disk drive has the following characteristics:

- 5.25 in.
- 5 disks
- 7 heads on 3745 models 130-170. 8 heads on 3745 model 17A.
- 733 cylinders
- 733 tracks
- 17 sectors per track
- 512 bytes per sectors
- The maximum readiness time after power ON is about 25 s
- The average access (seek) time is about 75 ms.

If the disk drive has not been used within 15 minutes, it is powered OFF by the MOSS.

The heads are automatically parked in the landing zone when the power is OFF.

The hard disk drive is an FRU.

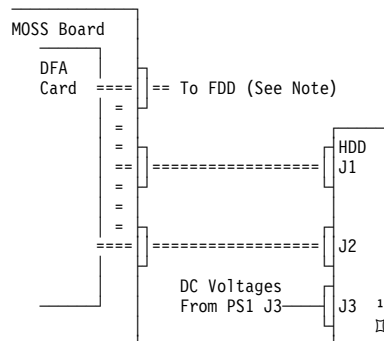

¹ = Jumper for drive select, set on position 1.

Note: Three Dot ORed lines (INDEX, READY, and TRACK 0) are common to the HDD and the FDD.

Figure 9-4. HDD Connection

For component locations, see YZ pages.

For connector pin assignment, see page YZ543.

Removal and Replacement Procedures

See *MIP*, Chapter 4 and *Service Functions*, Chapter 11 for HDD initialization.

Part Number

See *3745 Parts Catalog*, S135-2012.

Flexible Disk Drive (FDD)

Description

The 3745 diskette drive has the following characteristics:

- 5.25 in.
- 2 heads
- 154 tracks
- 15 sectors per track
- 512 bytes per sector
- The average readiness time after power ON is about 1 s
- The average access (seek) time is about 92 ms.

If the diskette drive has not been used within 15 minutes, it is powered OFF by the MOSS.

The diskette drive is an FRU with its own power supply.

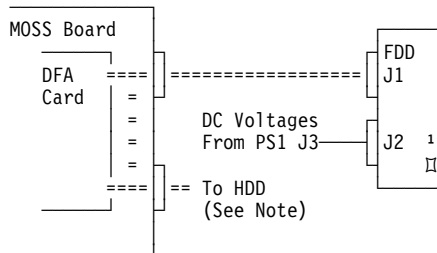

¹ = Jumper for drive select, set on position 0.

Note: Three Dot ORed lines (INDEX, READY, and TRACK 0) are common to the HDD and the FDD.

Figure 9-5. FDD Connection

For component locations, see YZ pages.

For connector pin assignment, see page YZ542.

Removal and Replacement Procedure

See *MIP* Chapter 4.

Part Number

See *Parts Catalog*.

Chapter 10. Power System

Power System in 3745 Models 130, 150, 160, and 170 Data Flow	10-2
The Power System in 3745 Model 17A Data Flow	10-3
Introduction	10-4
AC Voltages Input	10-5
AC Voltages Limits	10-5
Frequency	10-5
Safety Statement	10-5
Primary Power Box	10-6
Power Supply 1 (PS1)	10-8
Power Supply 2 (PS2)	10-13
Disk and Diskette Drive ON/OFF Control	10-14
Power Control Subsystem	10-15
Power Control Data Flow	10-16
Power Control	10-17
Power Mode of Operation	10-20
Local Mode	10-20
Host Mode	10-20
Network Mode	10-20
Switching From One Mode to Another.	10-21
Power ON/OFF Sequence	10-22
Power ON Sequence	10-22
Power OFF Sequence.	10-23
Scheduled Power ON Function	10-23
AC Detection and AC Monitoring	10-26
Air Flow Detector	10-27
Power ON Reset (POR)	10-29
POR Principle	10-29
Power ON Reset Paths	10-29
3746 Model 900 Power Connection and Control	10-34

Power System in 3745 Models 130, 150, 160, and 170 Data Flow

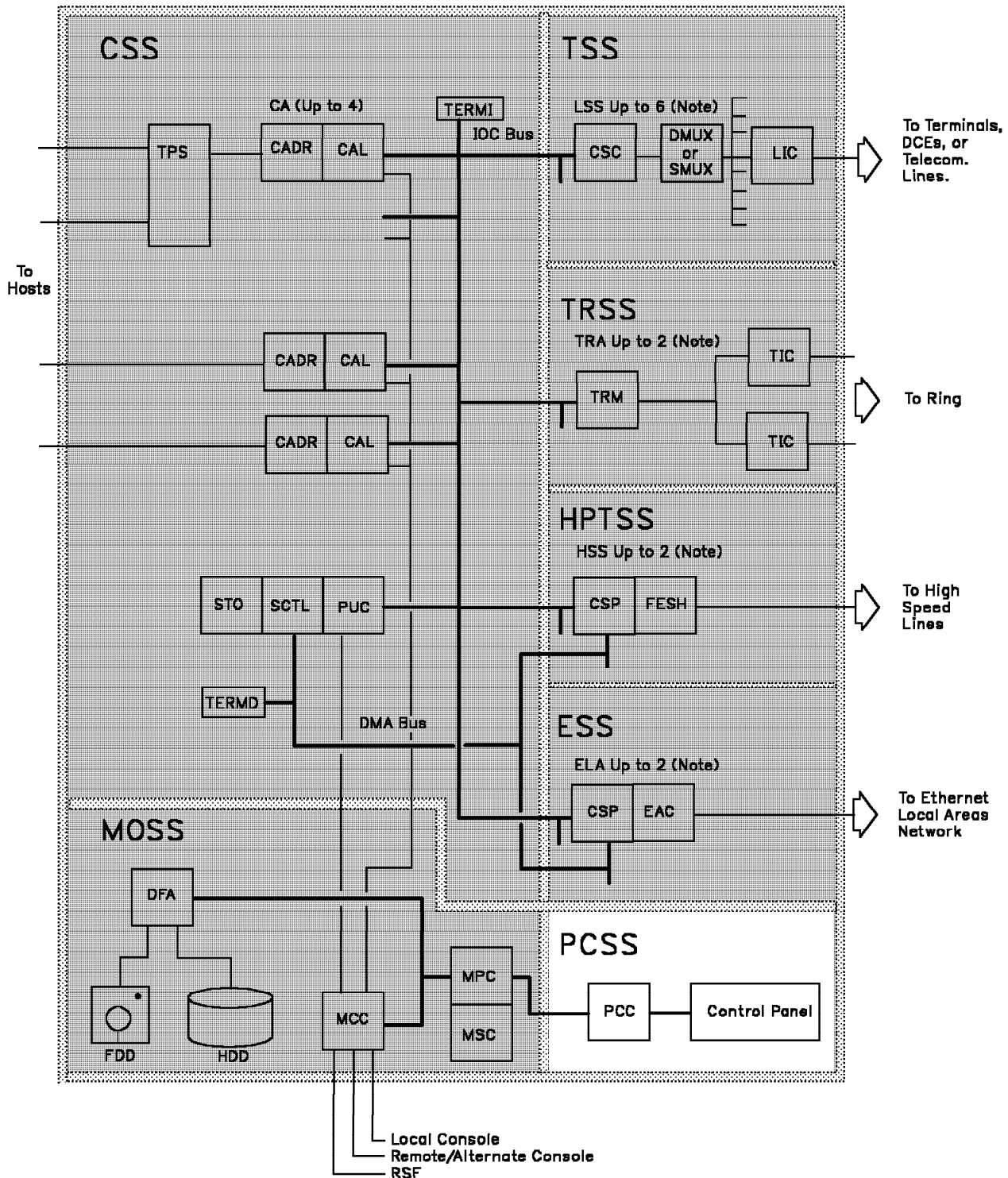

The Power System in 3745 Model 17A Data Flow

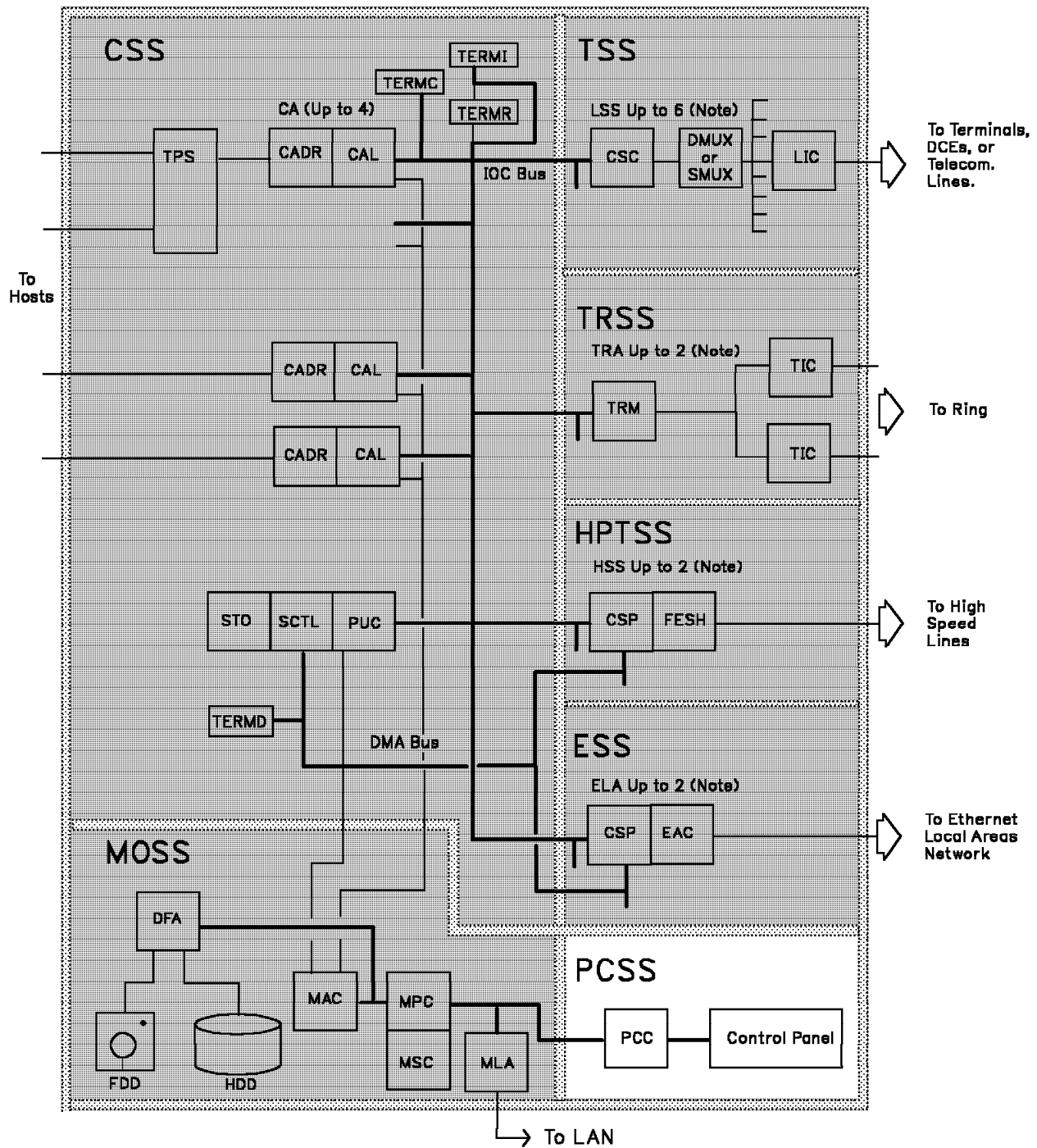

(Note) The number of LSS+HSS+ELA does not exceed 6

Figure 10-1. The Power System in 3745 Model 17A Data Flow. For model 17A, DMA and IOC buses are connected to the CBC in the 3746-900. This MLA card links the MOSS to the Service Processor through a LAN.

Introduction

The power system consists of:

- One primary power box for AC distribution.
- One power control card (PCC) for power control subsystem function.
- One power supply 1 (PS1) for DC voltages.
- One power supply 2 (PS2) for DC voltages to fans, control panel, and PCC card (PS2 is located inside the primary power box).

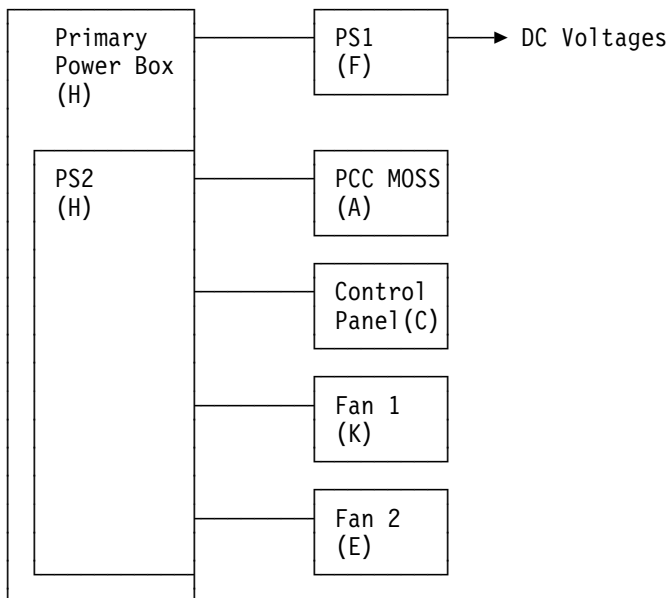

(x)= Component location on pages YZ010 and YZ011.

AC Voltages Input

The power subsystem operates with a single phase distribution.

AC Voltages Limits

Voltages			
Nominal	200/208	220	240
Minimum	180	193	210
Maximum	220	240	260

AC Voltage Input Adjustment

AC voltage input adjustment must be done on the primary power box using the SW1 switch. Three positions are possible: 200, 220, and 240 volts. See Figure 10-2 on page 10-6 for SW1 switch location.

Frequency

The 3745 can operate at one of the following frequencies:

- 50 Hz \pm 1 Hz
- 60 Hz \pm 1 Hz

Safety Statement

Input output cables must comply with the following safety statement:

For AC Voltage Input Hazardous voltage circuits (with AC voltages input) comply with IEC 950 - Class I, reinforced insulation.

For DC Voltage Outputs

- LIC type 5 or 6 are TNV Circuits (Telecommunication Network Voltage)

Or

- All other are SELV Circuits (Safety Extra Low Voltage)

Primary Power Box

Primary Power Box Component Location

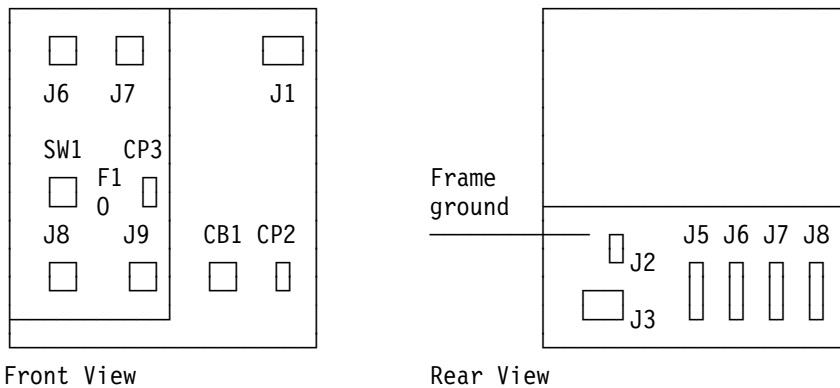

CB1 = Main CB
CP2 = AC for PS2
CP3 = DC for fans
F1 = 28-volt fuse for control panel and PCC card
J1 = AC to PS1
J6 = DC to fan 2
J7 = DC to fan 1
J8 = To UEPO switch
J9 = PS control to MOSS
SW1:= Voltage adjustment switch (200, 220, or 240 volts)

J2 = Customer plug (see following details)
J3 = AC input
J5-J8 = EPO plugs

Figure 10-2. Primary Power Box Component Location

Customer Plug

The J2 connector is for the customer and provides a normal-open contact when the power is OFF, and reverse its state when the power is ON.

Electrical Characteristic:
30 volts AC or 42.4 volts peak or DC, at 20 to 500 mA.

For details, see page YZ561.

Primary Power Box Distribution

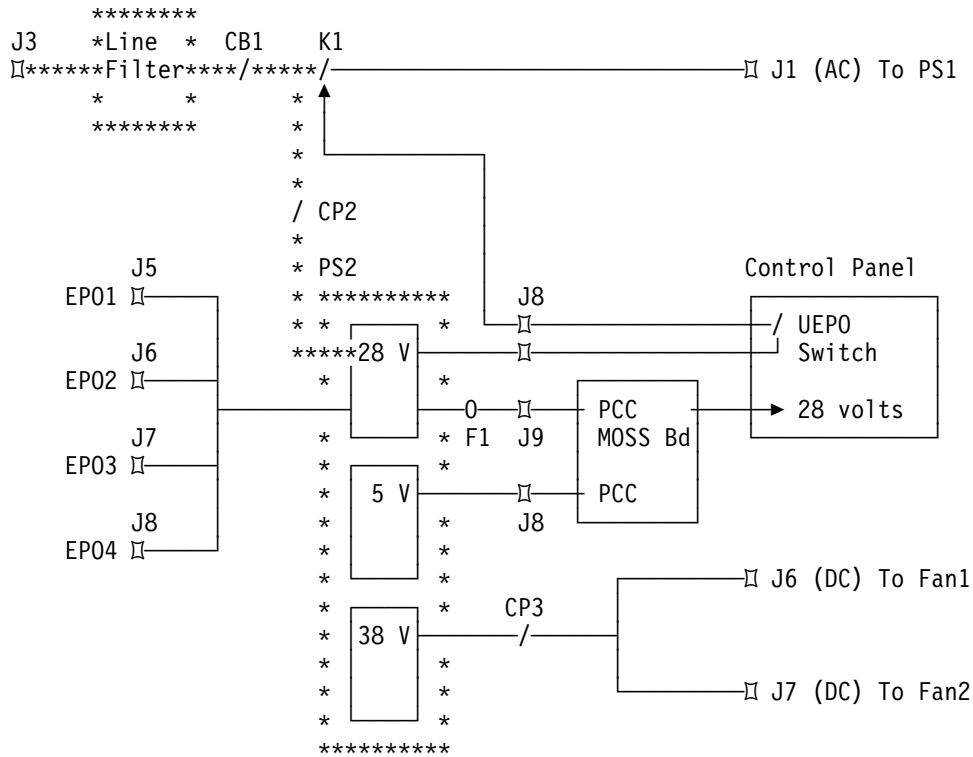

*** = Lines show hazardous areas where hazardous AC voltages are still present when power is switched OFF at the control panel.

See YZ pages for details.

Power Supply 1 (PS1)

IMPORTANT

Power supply PS1 is a sealed unit. It cannot be opened for maintenance.

PS1 Connection Layout

Primary
Power Box
(01H)

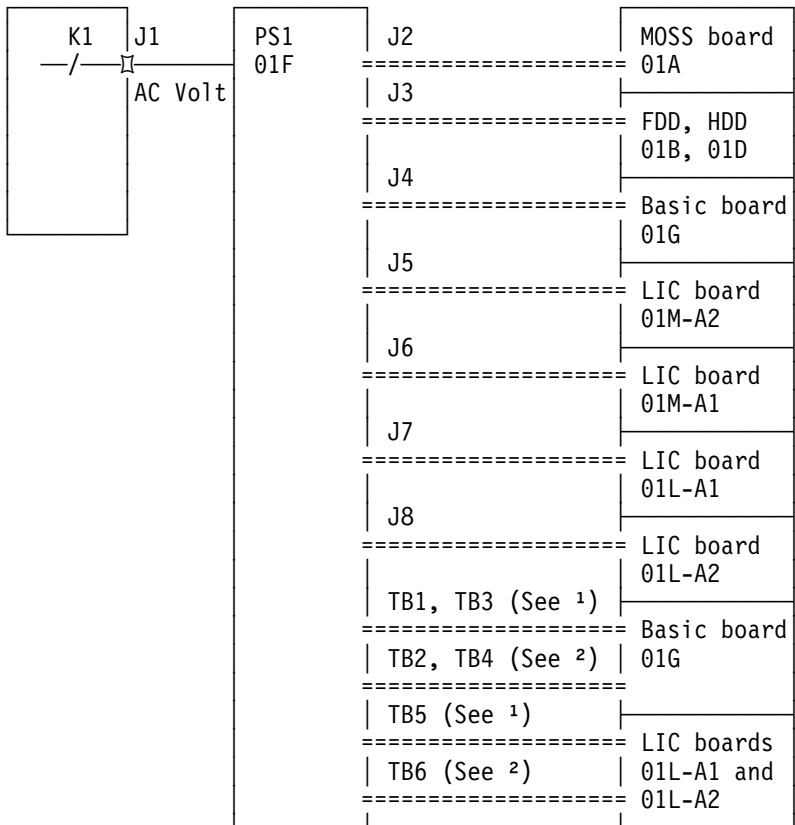

¹ = + 5 volts level 6

² = + 5 volts return level 6

See YZ pages for details.

PS1 Component Locations

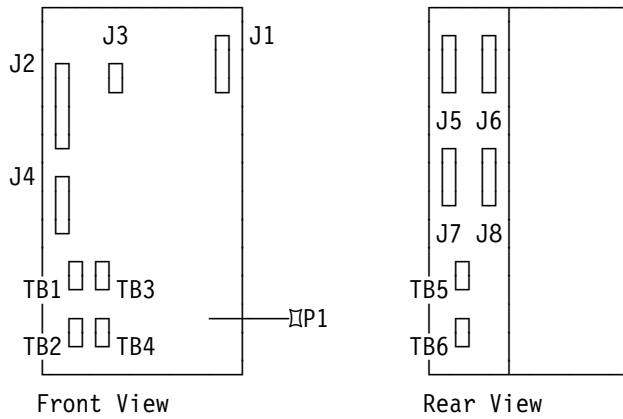

Connectors J2 to J8 and TBs, see YZ pages for details.
 Test connector J1, see "PS1 DC Voltage Test Points." for pin assignment.

PS1 DC Voltage Test Points.

J1	o	1 = + 12.0 volts level 1
	o	2 = + 12.0 volts level 2
	o	3 = + 8.5 volts level 3
	o	4 = + 5.6 volts level 4
	o	5 = + 5.0 volts level 5
	o	6 = + 5.0 volts level 6
	o	7 = + 5.0 volts level 7
	o	8 = - 5.0 volts level 8
	o	9 = - 8.5 volts level 9
	o	10 = PS fault test
	o	11 = OC fault test
	o	12 = DC common

PS1 DC Voltages and Tolerances: Test points on the power supply are for DC voltage Vmin or Vmax measurement only.

<i>Table 10-1. PS1 Voltages and Tolerances</i>				
VDC	Level	Vmin	Vmax	J1 Test Point ¹
+ 12.00	1	+ 11.00	+ 13.00	1
+ 12.00	2	+ 11.60	+ 12.60	2
+ 8.50	3	+ 7.90	+ 9.35	3
+ 5.60	4	+ 5.43	+ 5.88	4
+ 5.00	5	+ 4.85	+ 5.25	5
+ 5.00	6	+ 4.85	+ 5.25	6
+ 5.00	7	+ 4.85	+ 5.25	7
- 5.00	8	- 4.80	- 5.50	8
- 8.50	9	- 7.90	- 9.35	9

¹ = These values are referenced to test point 12.

Voltage Test Points and Tolerances on Board: For + 12 volts levels 1 and 2, and + 5 volts level 7, see “Disk Voltages and Tolerances (From PS1)” on page 10-14.

Recommendation: Ripple evaluation is a delicate measurement and should be performed only under the supervision of Product Engineering. A differential probe attached to a 10 MHz bandwidth scope shall be used. Using a scope with a larger bandwidth may give larger ripple values.

MOSS Board DC Voltages and Tolerances

<i>Table 10-2. MOSS Board Voltages and Tolerances</i>				
VDC	Level	Vmin	Vmax	Ripple
+ 8.50	3	+ 7.65	+ 9.35	0.15 p-p
+ 5.00	5	+ 4.75	+ 5.25	0.10 p-p
- 5.00	8	- 4.70	- 5.50	0.10 p-p
- 8.50	9	- 7.65	- 9.35	0.15 p-p

For test point pin locations, see page YZ331 or YZ031 for ripple measurement.

Basic Board DC Voltages and Tolerances

Table 10-3. Basic Board Voltages and Tolerances

VDC	Level	Vmin	Vmax	Ripple
+ 8.50	3	+ 7.65	+ 9.35	0.15 p-p
+ 5.60	4	+ 5.43	+ 5.88	0.10 p-p
+ 5.00	6	+ 4.75	+ 5.25	0.10 p-p
- 5.00	8	- 4.70	- 5.50	0.10 p-p
- 8.50	9	- 7.65	- 9.35	0.15 p-p
+ 1.70 ¹	-	+ 1.70	+ 1.79	0.10 p-p

For test point pin locations, see page YZ331.

¹ This voltage is for HSS line adapters. It is generated by two DC regulator cards (DCREG) located on the basic board:

- DCREG located in 01G-A1 ZG supplies HSS line adapter number 3.
- DCREG located in 01G-A1 ZE supplies HSS line adapter number 4.

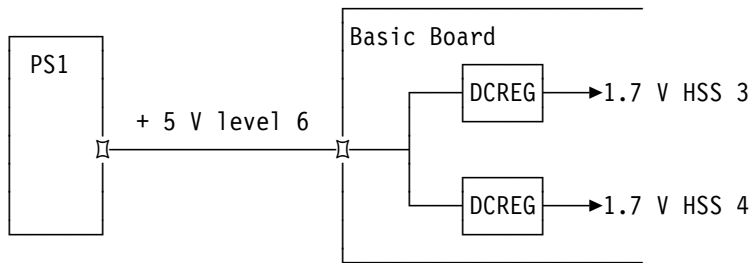

For DCREG card location see page YZ033.

CSP, FESH, and EAC Voltages and Tolerances: The EAC card uses + 5.00V voltage only.

VDC	Vmin	Vmax
+ 8.50	+ 7.60	+ 9.35
+ 5.00	+ 4.75	+ 5.25
+ 1.70	+ 1.60	+ 1.79
- 5.00	- 4.50	- 5.50
- 8.50	- 7.60	- 9.35

For test point pin locations, see page YZ732.

LIC Boards 01M-A1 and 01M-A2 DC Voltages and Tolerances

<i>Table 10-4. LIC Boards 01M-A1 and 01M-A2 DC Voltages and Tolerances</i>				
VDC	Level	Vmin	Vmax	Ripple
+ 8.50	3	+ 7.65	+ 9.35	0.15 p-p
+ 5.00	5	+ 4.75	+ 5.25	0.10 p-p
- 5.00	8	- 4.70	- 5.50	0.10 p-p
- 8.50	9	- 7.65	- 9.35	0.15 p-p

For test point pin locations, see page YZ738 for LIB1/3 boards (LICs 1-4), and page YZ739 for LIB2 board (LICs 5-6).

LIC Boards 01L-A1 and 01L-A2 DC Voltages and Tolerances

<i>Table 10-5. LIC Boards 01L-A1 and 01L-A2 DC Voltages and Tolerance</i>				
VDC	Level	Vmin	Vmax	Ripple
+ 8.50	3	+ 7.65	+ 9.35	0.15 p-p
+ 5.00	6	+ 4.75	+ 5.25	0.10 p-p
- 5.00	8	- 4.70	- 5.50	0.10 p-p
- 8.50	9	- 7.65	- 9.35	0.15 p-p

For test point pin locations, see page YZ738 for LIB1/3 boards (LICs 1-4), and page YZ739 for LIB2 board (LICs 5-6).

Power Supply 2 (PS2)

PS2 is a FRU and is located inside the primary power box
For component location see YZ pages.

PS2 Connection Layout

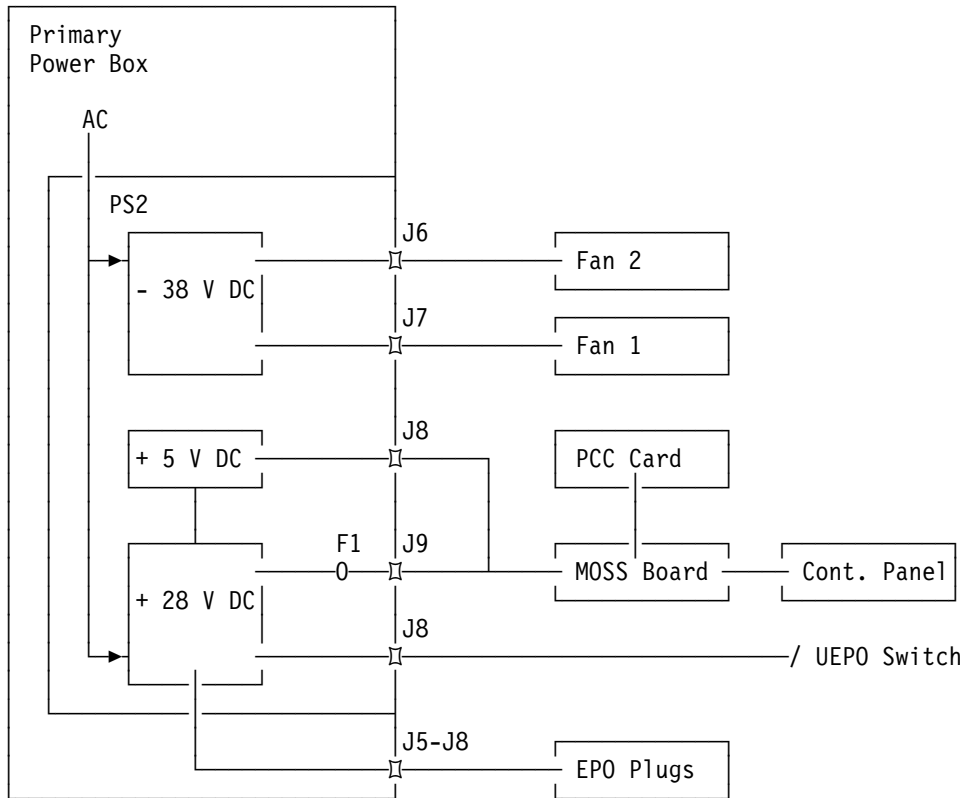

F1 = Fuse
For details, see YZ pages.

PS2 DC Voltages and Tolerances

VDC	Vmin	Vmax	Test Point
+ 5.00	+ 4.75	+ 5.25	01A-A1 J3 pin 22 ¹
+ 28.00	+ 24.90	+ 29.50	01A-A1 J3 pin 21 ¹
- 38.00	- 34.20	- 41.80	01H-B1 J6/J7 pin 2 ²

¹ = These values are referenced to test point 01A-A1 J3 pin 8.
See page YZ331 for pin location.

² = This value is referenced to 01H-B1 J6/J7 pin 1.
See page YZ060 for connector location.

Disk and Diskette Drive ON/OFF Control

DC voltages +5V and +12V are supplied by the PS1 to the disk (HDD) and diskette (FDD) drives, when the PS1 receives a 'HDD ON' or 'FDD ON' command from the MOSS through the PCC card.

If the disk and diskette drives have not been used within 15 minutes, the PS1 receives from the MOSS the 'HDD OFF' and 'FDD OFF' commands, and DC voltages are no longer applied to the drives.

Disk and diskette can be also controlled manually (DIF function 7).

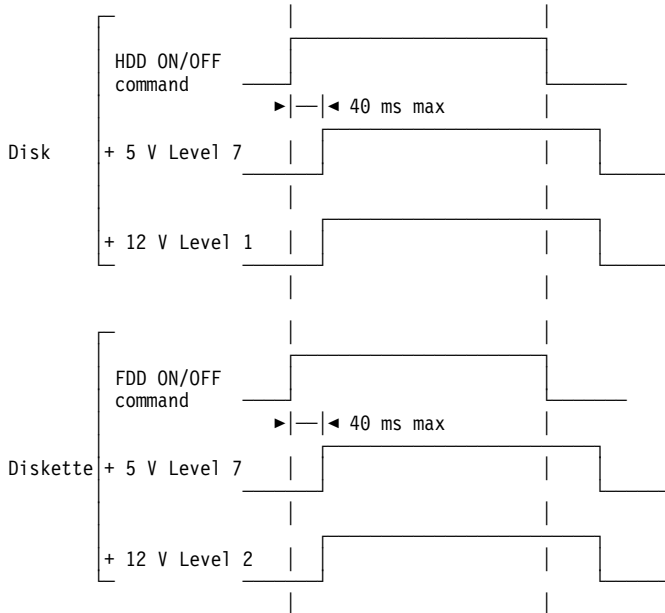
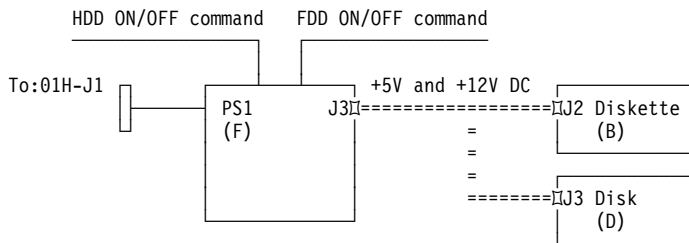

Disk Voltages and Tolerances (From PS1)

VDC	Level	Vmin	Vmax	Ripple
+ 12.00	1	+ 10.80	+ 13.00	0.10 p-p
+ 12.00	2	+ 11.40	+ 12.60	0.10 p-p
+ 5.00	7	+ 4.75	+ 5.25	0.10 p-p

For DC test points, see pages YZ.

Power Control Subsystem

The power control subsystem has in charge the following functions:

- Powering the machine ON/OFF either in local, host or network mode.
- Monitoring the power supply state.
- Monitoring the airflow.
- Individual reset function for any dedicated subsystems or adapter.
- The time function in order to give to the MOSS the local time and to allow the scheduled power ON function.
- The Scheduled Power ON of the whole machine (only in network mode).
- The communication between the control panel and the MOSS.
- The display on the control panel of the stacked power or fan faults.
- The main line survey in order to detect AC main utility failures.
- The automatic restart function on an AC main utility failure.
- The diagnostic tests of the power control subsystem and the control panel.
- The monitoring of the remote power OFF signal coming from the CCU.
- The logging of all faults to report them to the MOSS.
- Power ON retry after a power OFF due to a fan or power supply fault.
- PCC dump process.

Power Control Data Flow

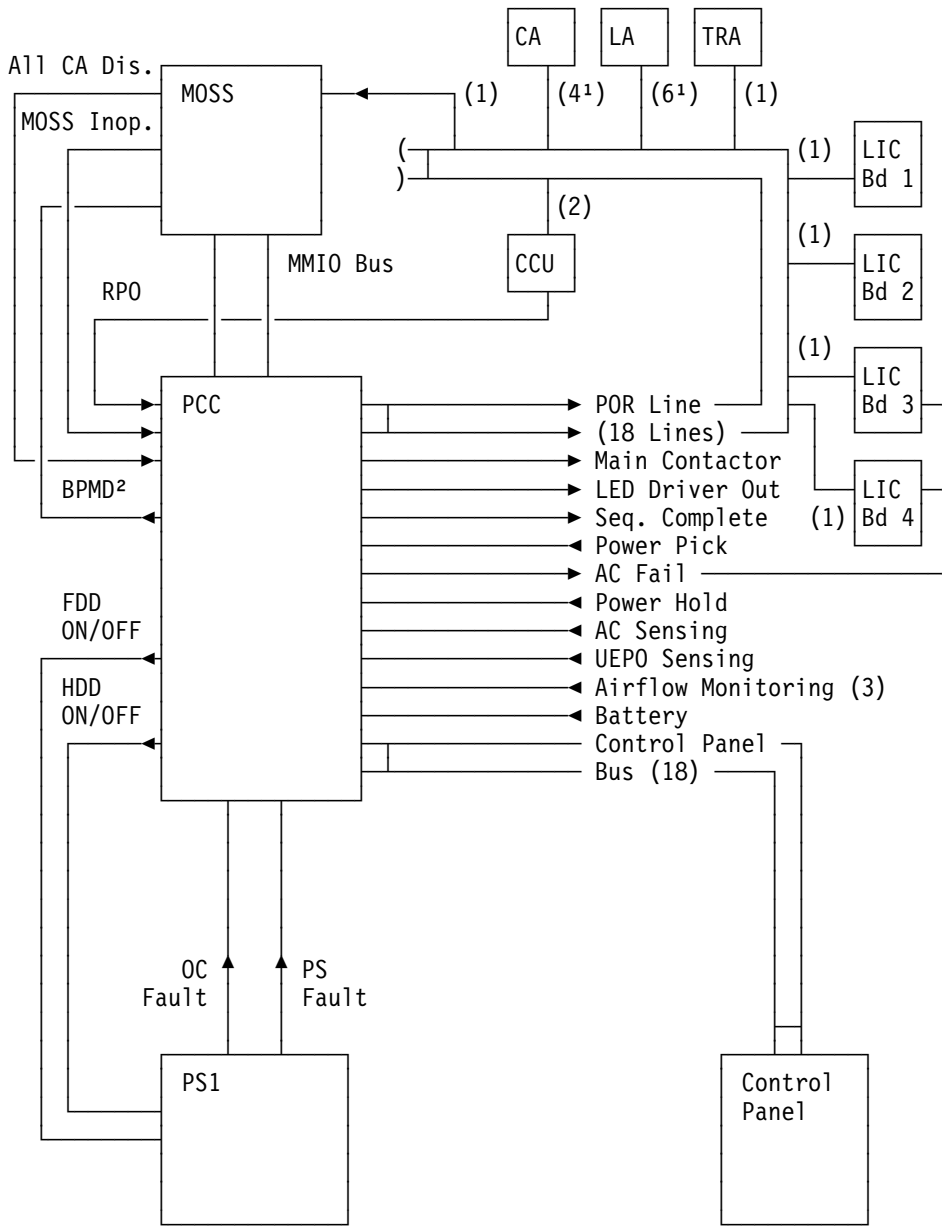

- () = Number of lines
- ¹ = One POR line per adapter
- ² = Bypass MOSS diagnostic

Figure 10-3. Power Control Data Flow

Power Control

The power control subsystem is made of two parts:

1. The power control card (PCC)
2. The control panel.

When AC is ON and the machine is switched OFF from the control panel, the power control subsystem is the only part of the machine powered ON.

The PCC card is located in the MOSS board .

The PCC is dedicated to the interconnection with the MOSS, the control panel, the power supplies PS1, and to the following signals:

- Power pick and hold signals
- Sequence complete signal
- AC fault signal
- Air flow detectors outputs
- Remote power OFF signal
- Main contactor command
- UEPO sense
- Battery monitoring
- AC fail.

PCC Interconnection

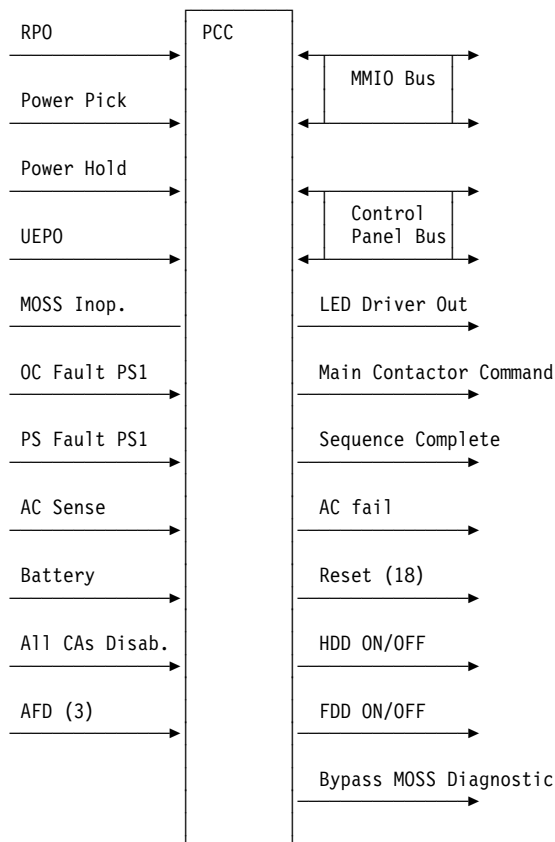

() = Number of lines

PCC Card MOSS Interconnection

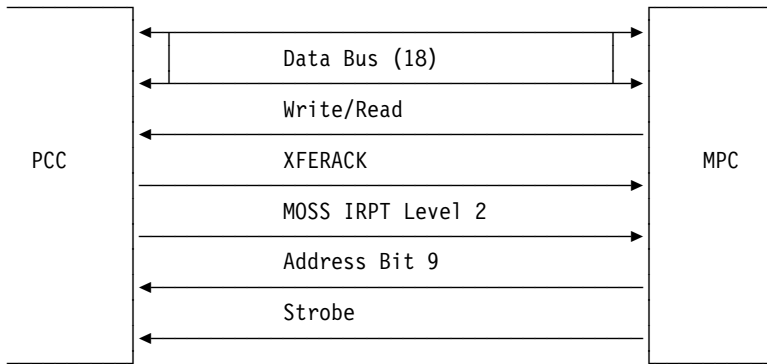

Data from MOSS to PCC Card

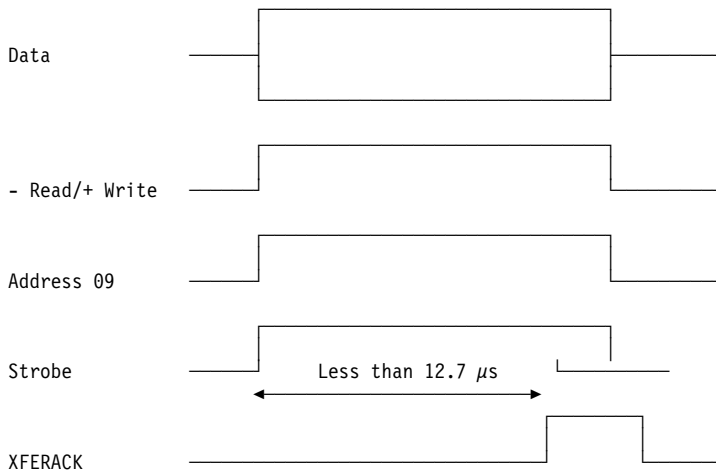

Data from PCC Card to MOSS

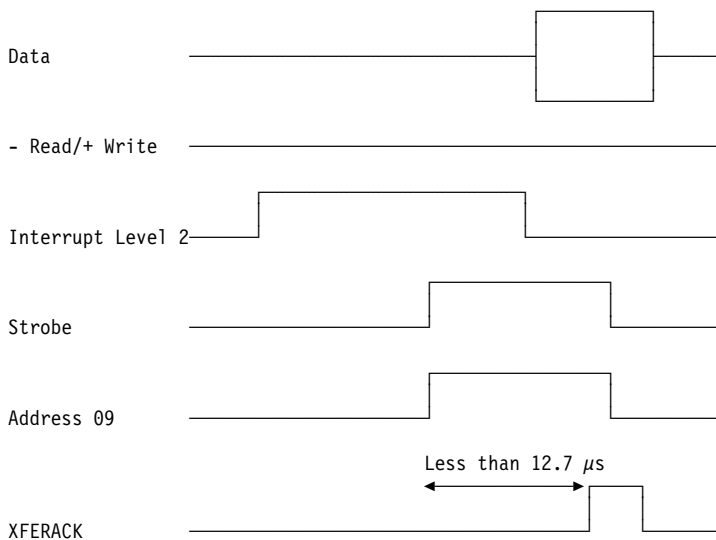

PCC Card Control Panel Interconnection

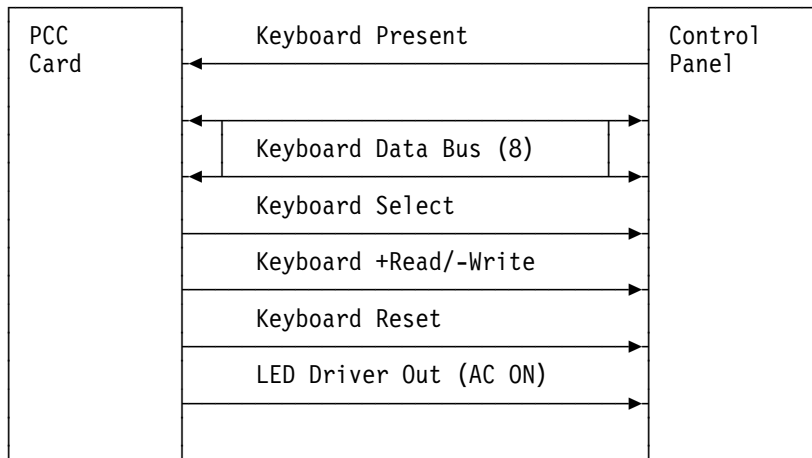

PCC Card Control Panel Data Timing

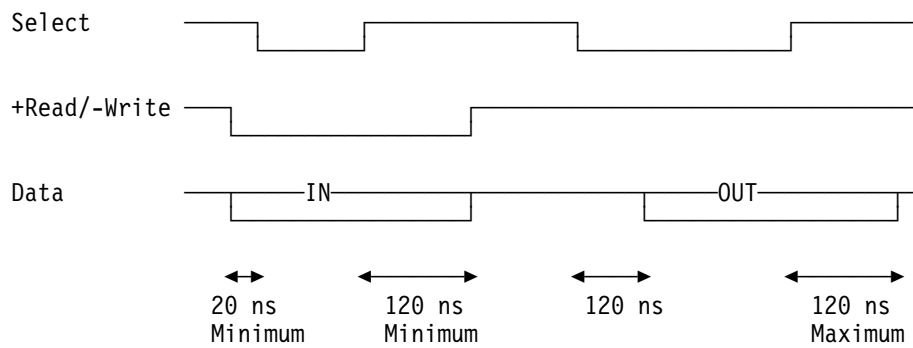

PCC Card Power Supply Signal Interconnection

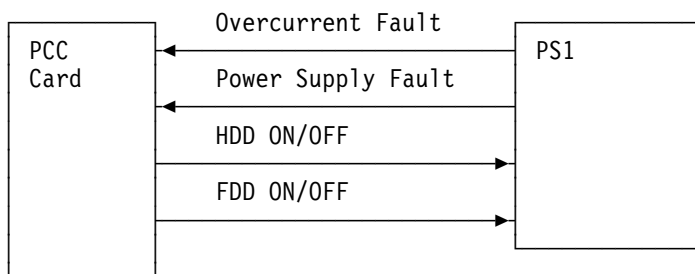

Power Mode of Operation

Local Mode

In local mode (3 at the power control window) the only way to power ON/OFF the 3745 is to do it manually from the control panel.

In this mode, for safety reasons, the Automatic Restart and the scheduled power ON functions are not available. In this mode the Power ON Reset of the machine is available from the control panel.

Host Mode

In host mode (1 at the power control window) the only way to power ON/OFF the 3745 is to do it from the locally-attached hosts, via external control cables.

When any of these hosts goes ON, the 3745 powers ON with a power pick command.

When all attached hosts have turned OFF (all power hold dropped) the 3745 turns OFF.

An EPO plug Part 8482303 must be installed in position J5 if no host EPO cables are installed. This plug prevents powering OFF the 3745 if the power control is set to position 1 (host mode), when no EPO cables are installed.

In this mode, the automatic restart and power ON retry functions are available.

Network Mode

In network mode (2 at the power control window) and only in this mode, the scheduled power ON function is available. As for all the other communication controllers, in this mode you can power ON the 3745 manually from the control panel, and you can power OFF the 3745 through the NCP (RPO function also called RMPO for VTAM). The scheduled power ON function does not disable the manual power ON or RPO functions. This means that you always have the ability to power ON the 3745 manually before the scheduled power ON time.

In this mode, the automatic restart and power ON retry functions are available.

In this mode the Power ON Reset of the machine is available from the control panel.

Switching From One Mode to Another.

- Switching from host or network to local does not impact the machine's Power ON/OFF status.
- Switching from local to host:

If OFF in local, the machine will be maintained OFF in host. It will be turned ON later by a power pick pulse from one attached host (if an AC main utility fault occurs, the Automatic Restart function will not apply even if one attached host is ON).

If ON in local, the machine will remain ON if at least one attached host is ON. Otherwise, the machine will go OFF.

- Switching from local to network:

If OFF in local, the machine will be maintained OFF in network, waiting for a manual power ON at the control panel or for a scheduled power ON action. If an AC main utility fault occurs after switching from local to network, the machine being OFF, the automatic restart function will not apply.

If ON in local, the machine will be maintained ON in network.

- Switching from host to network:

The machine power ON/OFF status is not impacted.

- Switching from network to host:

If OFF in network, the machine will be maintained OFF in host. It will be turned ON later by a power pick pulse from one attached host (if an AC main utility fault occurs, the automatic restart function will not be applied even if one attached host is ON).

If ON in network, the machine will remain ON if at least one attached host is ON. Otherwise, the machine will go OFF.

Power ON/OFF Sequence

Power ON Sequence

The normal power ON sequence is initiated by:

- Manual power ON at the control panel if the machine is in local or network mode.
- Power pick command (from one attached host) if the machine is in host mode.
- Automatic restart function on an AC main utility failure if the machine was powered ON in host or network mode when the failure occurred.
- Scheduled power ON function if the machine is in network mode.

The PCC card first activates the reset lines of all the adapters

Then the main contactor command signal will turn ON the power supplies.

Then the LED driver out signal is activated.

After a 1 second wait the PCC checks the fault signals (overcurrent (OC) and power supply (PS) faults) of both power supplies. If no fault, the reset lines are deactivated 100 ms later.

Then the disk (HDD) and the diskette (FDD) are powered ON.

MOSS IML will start, and at the end of IML the MOSS will ask the PCC card which type of power ON was done (local, host, network, scheduled, automatic restart), the power ON time and the last power OFF time.

At the end of the power ON sequence, and if the machine is in host mode, the sequence complete signal is sent to the host.

Note: When the machine is in local or network mode, this signal is forced permanently, whether the machine is power ON or OFF.

In host or network mode, if there is a fault on a power supply, the power ON sequence is stopped, the PCC deactivates the AC via the main contactor command signal, waits ten seconds and then re-issues another power ON sequence. This is done two more times before the final power OFF.

Power OFF Sequence.

The normal power OFF sequence is initiated by :

- Manual power OFF at the control panel if the machine is in local mode.
- The remote power OFF (RPO also called RMPO for VTAM) signal, if the machine is in network mode.
- The drop of the last host power hold signal if the machine is in host mode.

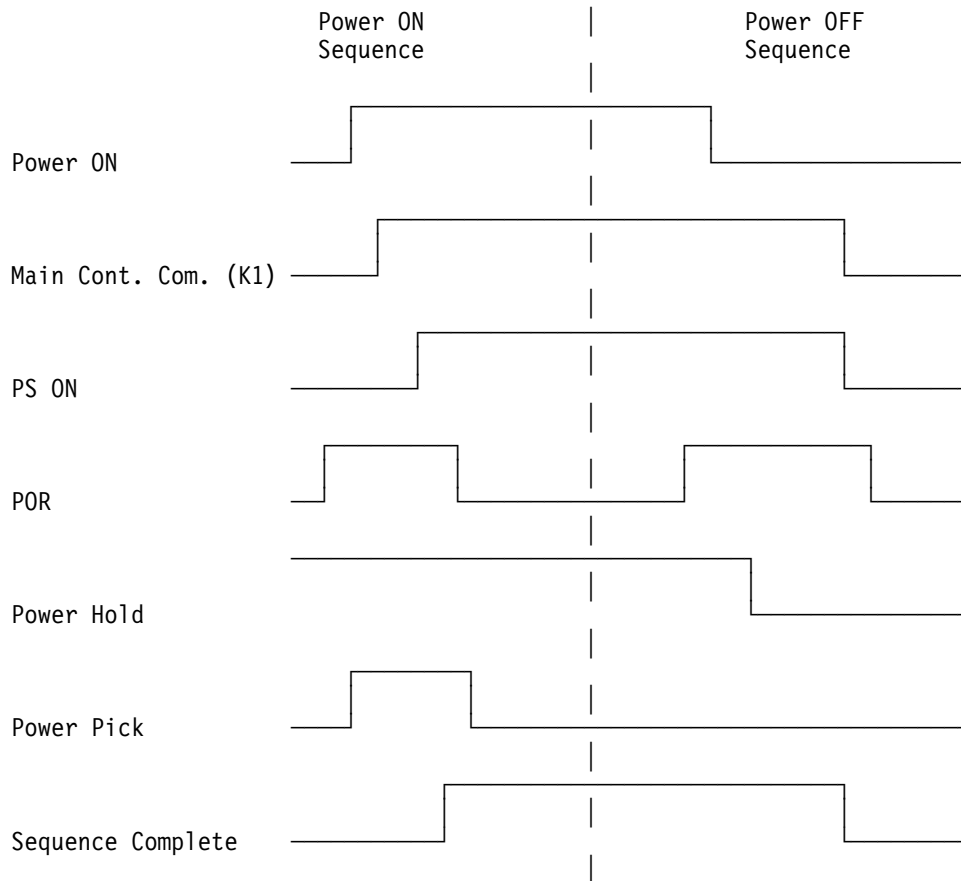

Scheduled Power ON Function

The purpose of the clock used in the power control subsystem is to keep time and calendar date through extended power OFF periods. This will allow scheduled power ON actions to be taken at a predetermined time and day of the week, independently of any intervening AC main power failures. Each day of the week may be associated with a different power ON time.

The logic for the scheduled power ON function is in the PCC card and is powered by a battery during AC main failures.

This function is available in network mode (2 at power control window) only, and is allowed or inhibited by the customer through the MOSS.

Manual Versus Scheduled Power ON

Manual power ON or power OFF through the NCP has priority over scheduled power ON. If power OFF through the NCP completes prior to a scheduled power ON point, then the power control subsystem will turn power ON when the predetermined point is reached. The scheduled power ON times of the current week will be considered valid for the following weeks if they are not changed.

Automatic Restart Function

For safety reasons, this function is not available in local mode.

The automatic restart function intends to assure a re-power ON of the system when the AC main is restored. There is a 10-second wait between the AC is restored and the auto restart takes place. If one AC main fault is detected, a fault event is sent to the MOSS (if the power supply of the MOSS is still operative):

The information will be stacked in the PCC card if the MOSS is inoperative.

When the AC main is restored, a machine auto-restart will take place if the AC main fault has resulted in a machine power OFF.

This is done after a 10-second wait. The machine automatically starts with a general IPL (function 0, service 0).

Power ON Retry Function

This function allows an automatic repower of the machine after an automatic power OFF due to any power supply or fan fault. This function is only available in host and network modes. The machine starts automatically with a general IPL (function 0, service 0).

Retry Sequence

1. A fault is detected
2. The machine is powered OFF
3. The fault is displayed on the control panel
4. A 10-second wait is performed
5. The machine is powered ON (retry).

The above sequence is performed up to three times before a final power OFF. The retry counter is cleared if there is no fault after IML completed and when the fan speed establishment time (one minute) is reached.

After three retries the display of the last fault is replaced by a display ('010') indicating to use the 'display stacked errors' function.

Power Status Monitoring

The power status is scanned cyclically to determine an eventual fault. If a fault occurs during this scanning, the machine is powered OFF, this fault is displayed on the control panel and stacked in the PCC card. After a 10-second wait, the machine is powered ON again. The same operation can be done three times. After three times the machine stays power OFF. See "Retry Sequence."

Individual Reset Function

This function allows the MOSS, via the power control, to perform selective resets for diagnostic purposes, or a general reset at power ON.

The PCC card has 18 reset lines to reset the different machine adapters. See Figure 10-3 on page 10-16 for details.

AC Detection and AC Monitoring

Main Line Survey

Major disturbances are defined as follows:

A 35 % or more dip in the minimum nominal voltage.

When this input is under the specified threshold during 40 ms, an AC failure is detected by the PCC card and the AC fail signal is generated. Two types of AC failure can be reported to the MOSS:

1. Valid AC failure:

a. Transient AC failure:

A failure defined as above (40 ms minimum) with a duration lower than T2 (45 ms).

b. AC failure:

An AC failure longer than T2 (45 ms). The whole machine is powered OFF.

2. Invalid AC failure:

The PCC card detects an AC failure, but the AC is still present after two seconds (false AC failure detection).

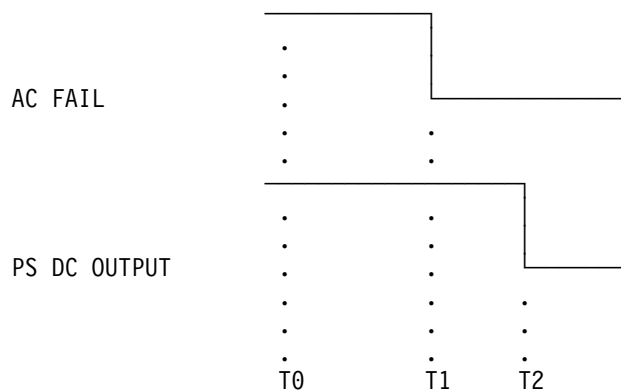

T0 : At this time the AC is going under the threshold

T1 : At this time the AC failure detection occurs

T2 : At this time the DC output is falling down

T0-T1 : AC failure detection time (40 ms minimum)

T0-T2 : PS hold up time (45 ms minimum)

Air Flow Detector

The fans have a speed detection (opto-coupler device) for the air flow detection.

The opto-coupler device sends a signal to the PCC card.

Air Flow Monitoring

The status of the fan is scanned cyclically to determine an eventual fault. If a fault occurs during this scanning the machine is powered OFF, this fault is displayed on the control panel and stacked in the PCC card. After a 10-seconds wait, the machine is powered ON again.

The same operation can be done three times . After three times the machine stays power OFF.

Opto-Coupler Device Output

AFD 1 and AFD 2

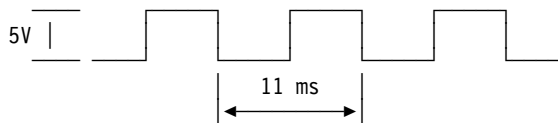

AFD 0

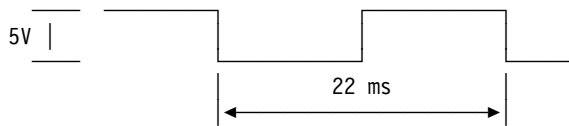

Air Flow Detection Principle

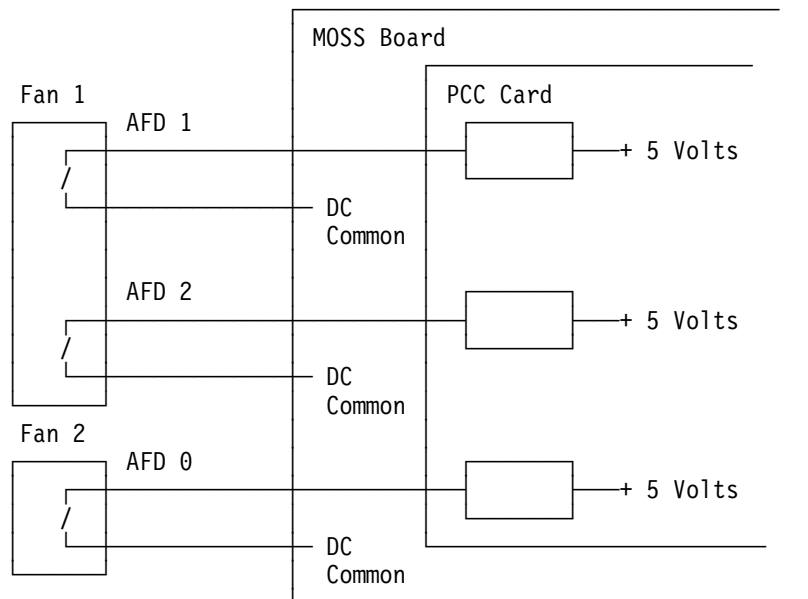

Power and Fan Stacked Faults

After three unsuccessful machine power ON retries, the power control displays code '010' on the panel (machine OFF due to three unsuccessful power ON).: This function allows to display the last four stacked faults. This can be done only by entering service 1 prior entering the function B .

Faults Logging

After any fault the power control sends a fault event to the MOSS. If the MOSS is not operative, this fault is stored in the PCC card and restored to the MOSS when it becomes operative.

Power ON Reset (POR)

POR Principle

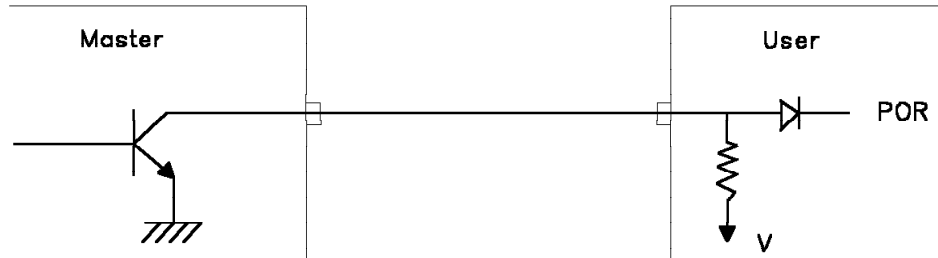
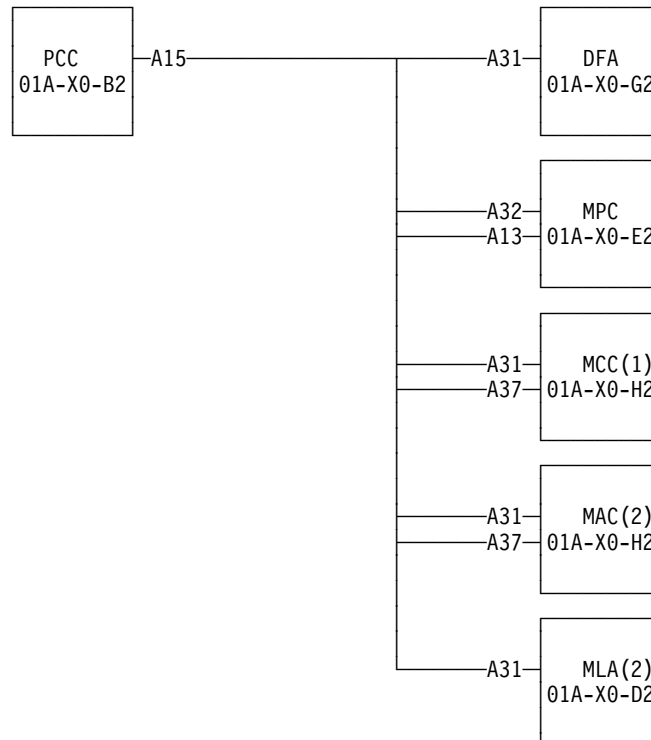

Figure 10-4. POR Principle

POR is always down level when active
Voltage level is provided by the user.

Power ON Reset Paths

MOSS Board



(1) = For 3745 Models 1x0
(2) = For 3745 Model 17A

Basic Board (CCU)

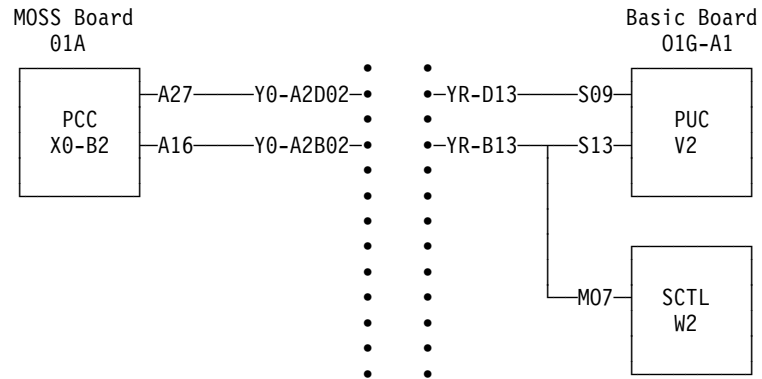

Basic Board (TRM)

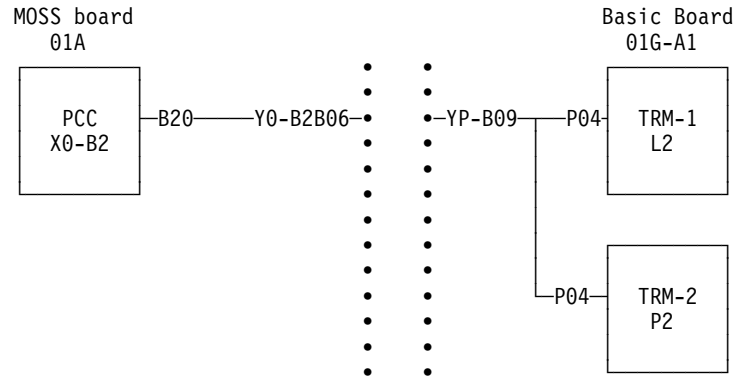

Basic Board (CA)

MOSS Board
01A

Basic Board
01G-A1

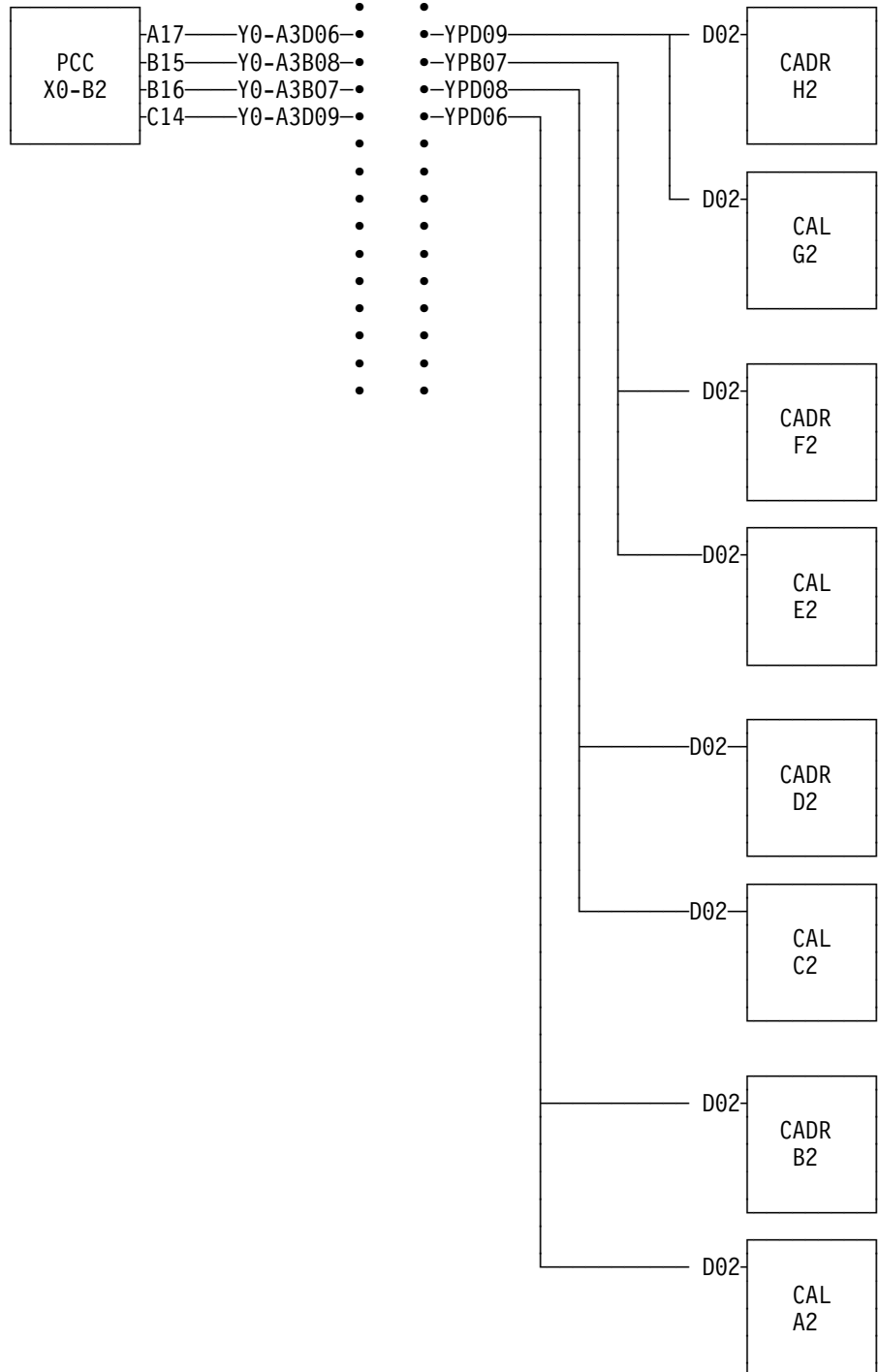

Basic Board (CSC/CSP)

MOSS Board
01A

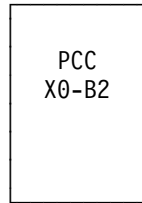

C15 — Y0-A3B02 — ●
 C16 — Y0-A3D02 — ●
 C17 — Y0-A3B04 — ●
 C18 — Y0-A3D03 — ●
 C19 — Y0-A3B05 — ●
 C20 — Y0-A3D05 — ●

●
 ● — YPB13
 ● — YPD13
 ● — YPB11
 ● — YPD12
 ● — YPB10
 ● — YPD10
 ●
 ●
 ●
 ●
 ●
 ●
 ●
 ●

Basic Board
01G-A1

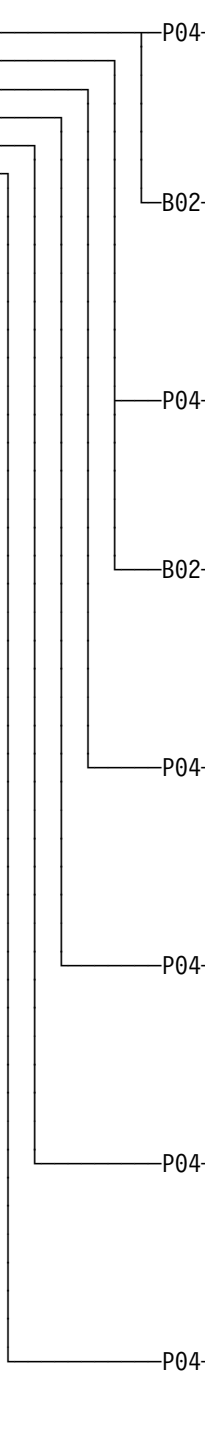
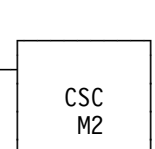
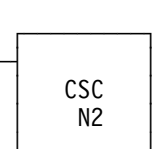
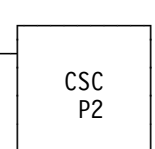
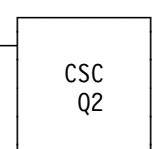
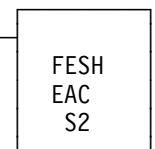
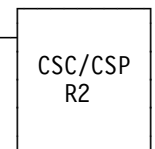
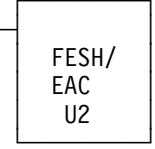
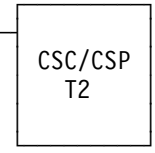

LIC Board Type 2

MOSS Board
01A

LIC Board 3
01L-A2

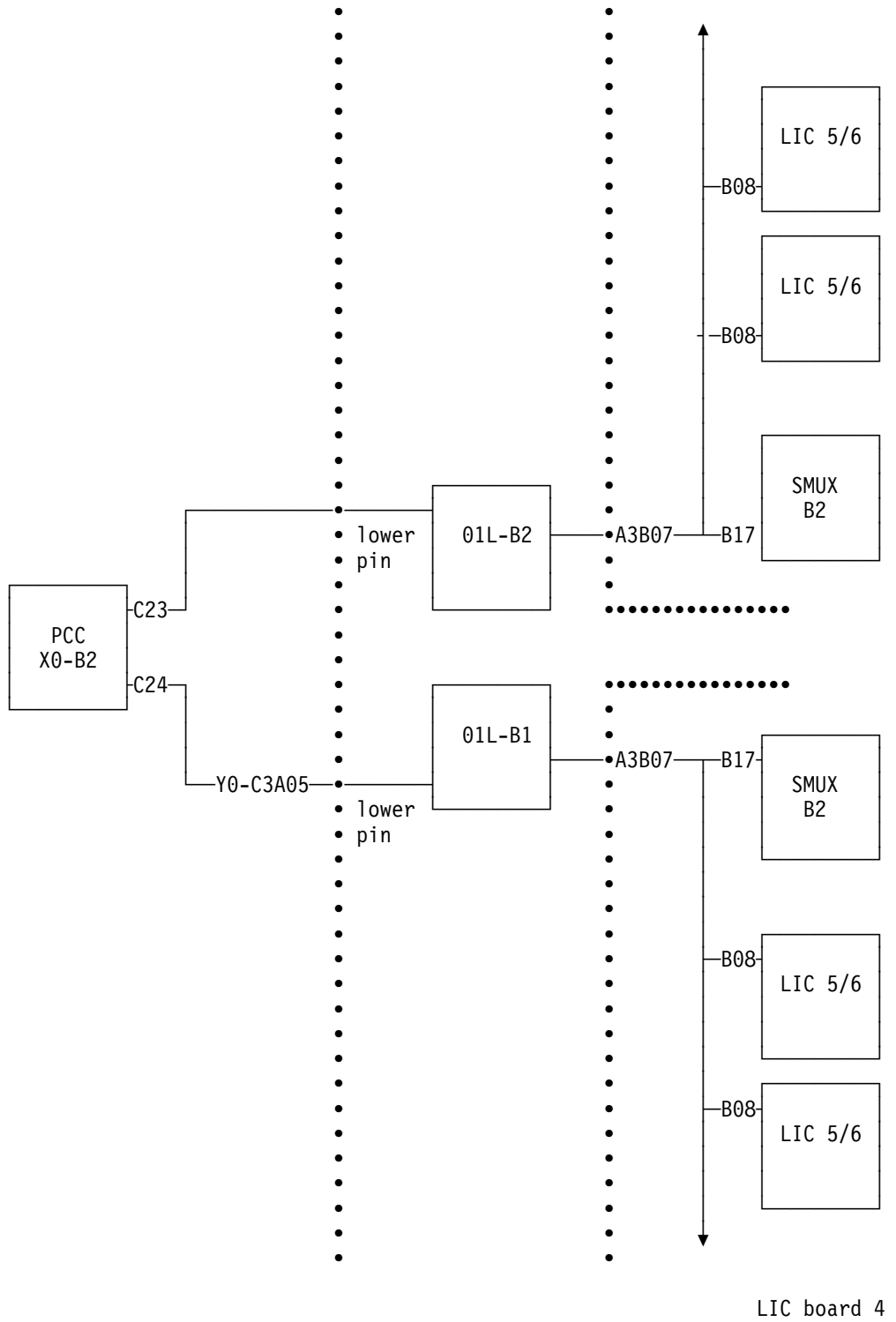

3746 Model 900 Power Connection and Control

For details on 3745/3746-900 power connection, power control to the 3746-900, and information on the 3746-900 power, refer to the *3746 Model 900 Hardware Maintenance Reference*, online documentation.

Chapter 11. Error Logging

Introduction	11-4
Hexadecimal Codes	11-4
Box Event Records (BERs)	11-4
BER Generalities	11-6
BER Generation	11-6
BER Type and Identification	11-9
BER Structure	11-10
BER Handling Tools	11-11
BERs Which Are Not Machine Errors	11-11
Specific Mechanisms	11-12
BER/Alarm/Alert Mechanism on a 3745 Down	11-12
Analysis of a BER/Alarm/Alert Sequence	11-13
BER Display	11-13
AutoMaint	11-16
AutoMaint Strategy	11-16
Automatic BER Analysis	11-18
General Process Flow	11-18
CE Field Updating	11-19
BER Reference Code	11-19
Manual FRU Correlation	11-20
Automatic FRU Correlation	11-20
Reference Code Structure	11-21
BER Recovery Procedures	11-24
MOSS Handling of 3745 Down	11-24
IOC Bus and Adapters	11-24
Scanner Errors Without BERs	11-24
Unresolved Interrupts	11-25
MOSS Error Logging	11-29
Hexadecimal Codes	11-29
Hexadecimal Codes Versus MOSS BER ID 00	11-29
MOSS BERs Used With the IPL Application	11-33
MOSS BER Type 01 - Summary	11-33
MOSS BER Type 01 ID 00 (Detailed BER Display)	11-39
MOSS BER Type 01 ID 00 - Field Description	11-39
BER TYPE 01 ID 00 Error Code Description	11-40
MOSS BER Type 01 ID 01	11-50
MOSS BER Type 01 ID 01 - Field Description	11-50
MOSS BER Type 01 ID 02	11-53
MOSS BER Type 01 ID 02 With MOSS Check 04	11-53
MOSS BER Type 01 ID 02 - Field Description	11-53
MOSS BER Type 01 ID 03	11-56
MOSS BER Type 01 ID 03 - Field Description	11-56
MOSS BER Type 01 ID 04	11-60
MOSS BER Type 01 ID 05	11-63
MOSS BER Type 01 ID 05 - Field Description	11-65
MOSS BER Type 01 ID 06 (Error 01 or 02)	11-66
MOSS BER Type 01 ID 06 (Error 03 or 06)	11-66
MOSS BER Type 01 ID 06 (Error 04)	11-67
MOSS BER Type 01 ID 06 (Errors 05/08 Ext 05/07)	11-72
MOSS BER Type 01 ID 06 (Error 07)	11-73

MOSS BER Type 01 ID 06 (Error 08 Ext 07)	11-74
MOSS BER Type 01 ID 06 (Error 09)	11-74
MOSS BER Type 01 ID 06 (Error 13)	11-76
MOSS BER Type 01 ID 06 (Error 14)	11-76
MOSS BER Type 01 ID 06 (Error 18)	11-76
MOSS BER Type 01 ID 06 (Error 28)	11-77
MOSS BER Type 01 ID 07	11-78
MOSS BER Type 01 ID 08	11-80
MOSS BER Type 01 ID 0A	11-81
MOSS BER Type 01 IDs 10 and 11	11-81
MOSS BER Type 01 IDs 12, 13, and 14	11-82
MOSS BER Type 01 ID 15	11-82
MOSS BER Type 01 IDs 16 and 1A to 1D	11-83
MOSS BER Type 01 - ID 1E	11-83
MOSS BER Type 01 ID 17	11-84
MOSS BER Type 01 ID 19	11-85
MOSS BER Type 01 ID 20	11-86
MOSS BER Type 01 ID 21	11-90
MOSS BER Type 01 ID 23 and 2A to 2E Field Details	11-92
MOSS BER Type 01 IDs 24 to 29, and 37	11-94
MOSS BER Type 01 ID 30	11-94
MOSS BER Type 01 ID 32	11-94
MOSS BER, Type 01 ID 36	11-95
MOSS BER Type 01 ID 38	11-95
MOSS BER Type 01 ID 39	11-96
MOSS BER Type 01 ID 43	11-97
MOSS BER Type 01 ID 44	11-101
MOSS BER Type 01 ID 50	11-102
MOSS BER Type 01 ID 80	11-102
MOSS BER Type 01 IDs 91, B3, C1, C2	11-102
MOSS BER Type 01 IDs A0 to A4 - Field Description	11-108
BER Formats on Disk	11-112
MOSS BERs Type 01 Formats	11-112
Diagnostics BER Type 03	11-123
Diagnostics BER Type 03 - Summary	11-123
Diagnostics BER Type 03 - Detailed BER Display	11-123
Diagnostic BERs Type 03 - Formats	11-124
Power BER Type 04	11-125
Power Subsystem BER Type 04 - Summary	11-125
Power BER Type 04 (Detailed BER Display)	11-125
Power BER Type 04 - Field Description	11-127
Power BER Type 04 - Formats	11-132
NCP ESS BER Type 08	11-133
ESS BER Type 08 - Summary	11-133
ESS BER Type 08 - Detailed BER Display	11-137
ESS BER Type 08 - Field Description	11-141
ESS BER Type 08 - Formats	11-143
NCP 3746 Model 900 BER Type 9	11-145
3746 Model 900 BER Type 9 - Summary	11-145
3746 Model 900 BER Type 9 Detailed BER Display	11-149
3746-900 BER Type 9 - Field Description	11-156
3746 Model 900 BER Type 09 - Formats	11-159
NCP CA BER Type 10	11-164
CA BER Type 10 - Summary	11-164

CA BER Type 10 (Detailed BER Display)	11-169
CA BER Type 10 - Field Description	11-173
CA BER Type 10 - Field Details	11-174
CA BER Type 10 - Formats	11-176
NCP TSS/HPTSS BER Type 11	11-179
TSS/HPTSS BER Type 11 - Summary	11-179
TSS/HPTSS BER Type 11 (Detailed BER Display)	11-184
TSS/HPTSS BER Type 11 - Field Description	11-187
TSS/HPTSS BER Type 11 - Formats	11-189
NCP/PEP BER, Type 12	11-191
NCP/PEP BER Type 12 Summary	11-191
NCP/PEP BER Type 12 (Detailed BER Display)	11-192
NCP/PEP BER Type 12 - Field Description	11-192
NCP/PEP BER Type 12 - Formats	11-193
NCP CCU BER Type 13	11-194
CCU BER Type 13 - Summary	11-194
CCU BER Type 13 (Detailed BER Display)	11-195
CCU BER Type 13 - Field Description	11-196
CCU BER Type 13 - Formats	11-197
NCP IOC BER Type 14	11-198
IOC BER Type 14 - Summary	11-198
IOC BER Type 14 (Detailed BER Display)	11-199
IOC BER Type 14 - Field Description	11-199
IOC BER Type 14 - Format	11-200
NCP TRSS BER Type 15	11-201
TRSS BER Type 15 - Summary	11-201
TRSS BER Type 15 (Detailed BER Display)	11-203
TRSS BER Type 15 - Field Description	11-206
TRSS BER Type 15 - Formats	11-208

Introduction

Hexadecimal Codes

During 3745 initialization, the hardware is checked before loading the NCP or PEP. While the different tests are running, they may encounter an error or an unusual event. The logging routines are in charge of indicating the anomaly, analyzing it and displaying a hexadecimal code on the operator's panel. The MIP gives an exhaustive list of all the errors and progression codes.

If a 3745 control panel error occurs, or if a MOSS IML threshold is reached, the control panel displays hexadecimal codes indicating the cause of the error. In parallel with the display of the hexadecimal code, a BER (box event record) may be built if the state of the machine's hardware permits it.

Thus very often there is a connection between a hexadecimal code and a BER. (See page 11-29).

Box Event Records (BERs)

The event logging procedure of the MOSS reports each error caused by either an intermittent failure or a 3745 down (controller re-IPL).

Any such event in a 3745 subsystem is reported first to the NCP/PEP, and then to the MOSS for logging. In this case, a BER is built in a place called check record pool (CRP), where MOSS has access to it. In some cases, a BER is built directly by the MOSS itself. In any case, the BER is stored in a buffer in the MOSS RAM. The BER built by the MOSS is called composite MOSS BER, and may contain several BERs (usually three). The MOSS also generates the power BERs and the diagnostic BERs. For the generation, the formatting, and the storage of the BERs, see page 11-6.

Note: Some BERs, generated during IML may have a date/time stamp of '00/00 00:00', because the MOSS has not yet fetched the date and time. These BER will appear in the correct sequence in the BER log and should be considered in problem determination.

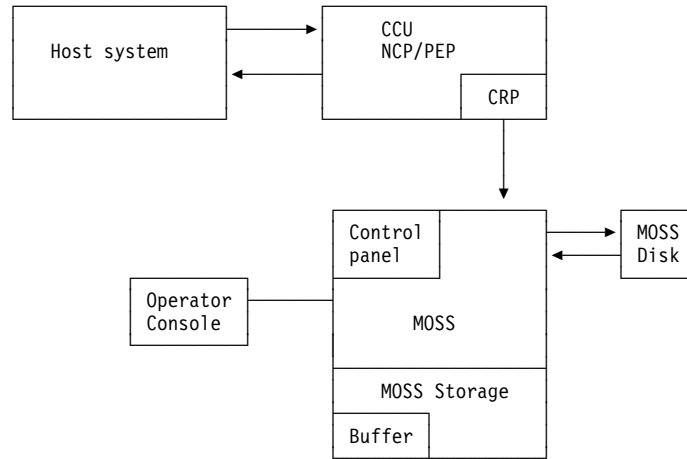

Figure 11-1. Box Event Records Handling

Thresholds

Errors are normally retried by the control program, or the microcode, in order to achieve fault tolerance and eliminate abends or loss of resources on intermittent failures.

When the count is maintained by the Control Program, the threshold values are found in the CDS at initialization (each NCP IPL).

For the whole machine, exhausting a threshold does not change the BER.

Table 11-1. Threshold Table

Function or Adapter	Threshold
PIO-CA	8
PIO-LA	8
AIO-1	2
ADP-CA	2
ADP-LA	2
Unresolved Level 1	2
Unresolved Level 2	2
Unresolved Level 3	2
Unresolved Level 4	2
PCI-2	2

BER Generalities

BER Generation

The MOSS creates the BERs from information supplied either by the NCP/PEP or by the MOSS itself.

If the MOSS is offline or not operational, the NCP/PEP stores the event or error information in the check record pool (CRP) located in main storage. When the CRP is full, each attempt to store more information increments a count in the CRP, but the information itself is lost. This count is entered into the last BER of the CRP (field **lost** in NCP/PEP BERs). When the MOSS comes back online, the contents of the CRP are transferred to the MOSS. The Figure 11-1 on page 11-5 describes how the information is handled (see also "BER Recovery Procedures" on page 11-24).

In case of MOSS I/O errors the error information supplied by the MOSS itself is stored in a composite BER with ID 85 (see page 11-30).

Automaint builds a reference code for each BER (see page 11-16).

BER Formatting

The MOSS identifies the BER with a number and formats the information together with date, time, flag and other control bytes in the MOSS storage buffer as follows:

Byte Number	Contents
1-2	Total BER length in bytes
3-4	BER number (identification)
5-12	Reference code
13-18	Reserved
19	Flag
20	CCU
21-24	Time of day (binary value in seconds)
25	Month (in packed decimal)
26	Day (in packed decimal)
27	Year (in packed decimal)
28	BER Type
29	BER ID
30-nnn	Error information (hexadecimal) (nnn is the total BER length)

Notes:

1. The MOSS formats the labels for BER display, and supplies both date and time given via time services.
2. The NCP date and time of the BERs may differ from that of the MOSS. The date and time is built by the MOSS when the BER is logged on the disk, and does not necessarily match the moment this event is acknowledged by the NCP.

3. The exact layout depends on the BER type and BER ID (see the BER formats description at the end of each BER type xx section).

Byte	21	22	23	24	25	26	27
Contents	00	00	F5	8F	12	21	87
Meaning	One bit = 1 sec 62 863 sec = 17h 27m 43s				Dec	21st	87

Figure 11-2. Example of Date and Time

NCP/PEP BER Formats Versus MOSS BER Formats: The following chart explains why the BER formats and contents of NCP/PEP-generated records are different from the MOSS-generated records.

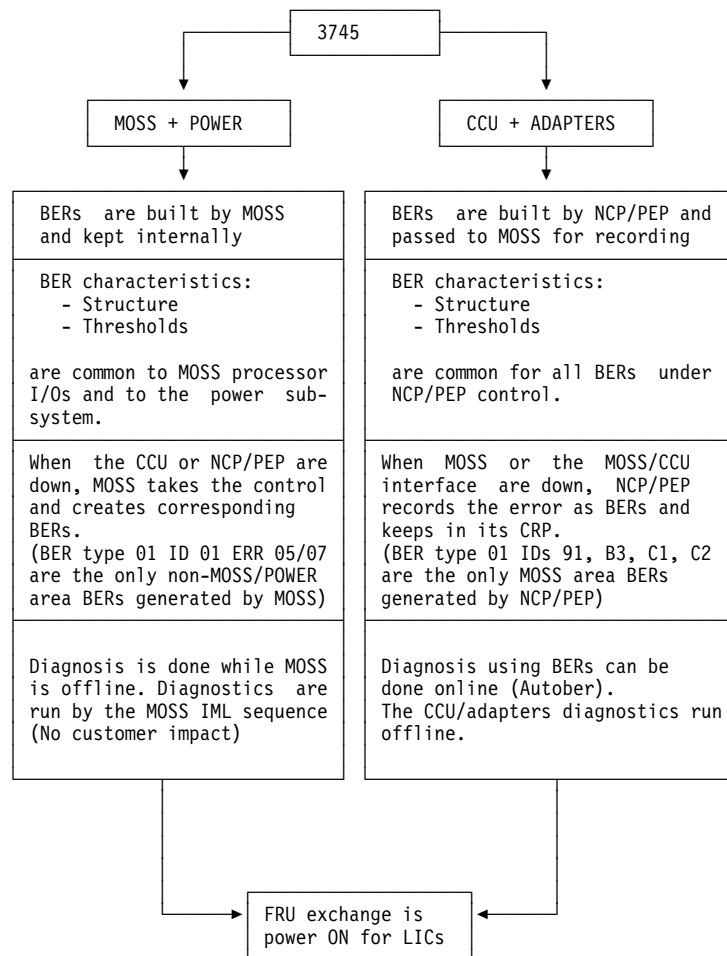

Figure 11-3. BER Formatting by MOSS and NCP/PEP

BER Storage on Disk

The MOSS stores the BERs, prepared in the MOSS RAM, on the **wraparound** BER file on disk in the order of their arrival.

When the BER file is full, the next BER to arrive overwrites the oldest BER (or BERs) in the BER file. No count is kept of such overwrites. The BER file may store several hundred BERs.

BER Storage when the Disk is not Operational: When the disk is not operational, the MOSS keeps the BERs in a buffer in the MOSS RAM. This buffer is preserved during MOSS IML (see Chapter 7). When the buffer is full, new BERs are lost, but a count of lost BERs is kept in a byte of the buffer. This is called the lost record count.

When the disk becomes operational again, MOSS stores the buffer in the BER file on disk, together with a BER giving the number of lost BERs in the event/error description line.

BER File Erasure: The entire BER file can be erased by using the DUMP/DPLY/DEL utility program. **The BER file should not be erased, except in exceptional cases**, since:

- It is not possible to erase individual BERs in the file, but only the entire BER file.
- The service personnel may need old BERs for history purposes.
- The BER file, when full, writes the most recent BERs on the disk space used by the oldest BERs (wraparound file). When the BER file is erased, a BER is logged to that effect in the file. For more details, see *Service Functions*, SY33-2069.

BER Display

Normally, you may access the BER file on the MOSS disk using the 'ELD Function' from the console. For more details on 'How to', see *Service Functions*.

The ELD detail display screen gives you the main information (also called 'fields') on the event represented by the BER.

Some of the fields may not appear on the ELD detail display, but they are part of the BER and they are listed as they appear in the BER file. See the section 'BER Formats on Disk' page 11-112. For more details, refer to *Service Functions* manual.

BER Type and Identification

BER Type

The first byte of information concerning the event, points to the general area of BER occurrence:

Type	Description
01	MOSS-related events or errors (plus events or errors recorded by MOSS when MOSS takes control of the box, or operations such as CCU hardcheck, scanner errors...
03	Diagnostic error detection (CE option)
04	Power subsystem errors, and events reported to MOSS by the power control
08	Events/errors related to ESS operations
09	Events/errors related to 3746-900 operations
10	Events/errors related to channel adapter operations
11	Events/errors related to transmission subsystem operations
12	Control program exceptions (software errors detected by the hardware)
13	CCU-related events/errors when NCP/PEP has control (excluding CCU hardcheck)
14	IOC bus-related errors, when not possible to attribute them to a specific adapter
15	TRSS events/errors related to token-ring subsystem operations

BER ID

The second byte identifies the category of error or event:

BER Created by the NCP/PEP

bit 0 Probable cause of the error.

OFF The most probable cause is the control program

ON The most probable cause is the hardware or the microcode

bits 1 to 3 Program level that recorded the error/event.

001	Control program level 1
010	" " " 2
011	" " " 3
100	" " " 4

BER Created by the MOSS: When a BER is created by the MOSS, a byte identifies the origin of the error or event.

The complete list of MOSS BER IDs is given in "MOSS BER Type 01 - Summary" on page 11-33.

Here the ID does not refer to event/error categories as in the NCP/PEP. For MOSS BERs, the event/error categories are found in another byte, called 'MOSS-CHECK'.

BER Structure

The BERs have a hierarchical structure, which allows going from the general problem area to the specific failing element.

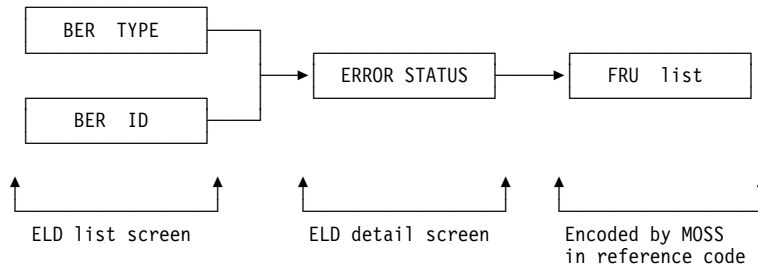

Figure 11-4. Hierarchical Structure of a BER

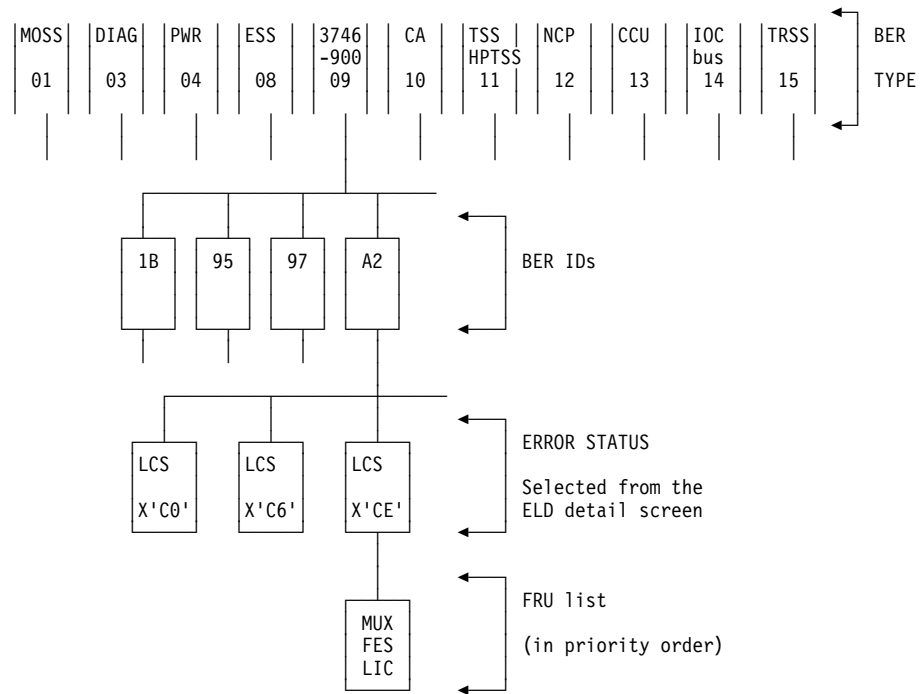

Figure 11-5. Example of a BER Tree Structure

Note: The **error status** is a predetermined field, characteristic of the error. BERs have a different **error status**, according to their type and ID.

BER Handling Tools

Function	Reference
Hexadecimal display at console Hexadecimal display versus MOSS BERs Host print request for BERs (MOSS ID 00 only) BER formats BER save, purge, display CE BER updating CE manual analysis Auto BER analysis	<i>3745 Maintenance Information Procedures</i> HMR page 11-29 For software information on BERs originated by NCP/PEP, refer to the associated product doc. HMR, end of every 'BER Type xx' section. <i>3745 Service Functions</i> HMR, page 11-19, and <i>3745 Service Functions</i> HMR, page 11-19. HMR, page 11-18.

BERs Which Are Not Machine Errors

Type	ID	EXT	Description	
01	06	01	BER file deleted	
		02	BER stack overflow	
		07	MOSS offline request by the operator	
	19	01		MOSS IML successful
				IPL complete without error
				IPL started
	24			Concurrent maintenance started
				Concurrent maintenance ended
				Concurrent maintenance cancelled
				Concurrent maintenance rejected due to traffic
			Concurrent maintenance NCP request to cancel	
03	01		Diagnostic started	
		02	Diagnostic completed successfully	
04	0A		Power control mode change	
			Set time of day	
			Air flow detected is OK	
			General power OFF (remote, network)	
			End of IML data due to an event	
			Battery changed	
08 11	96		Scanner disconnect state: The scanner has been disconnected by a request from the MOSS operator, and is reporting this to the control program.	
			TRM disconnect state: The TRM has been disconnected by a request from the MOSS operator, and is reporting this to the control program.	

Figure 11-6. BERs which are not Machine Errors

Specific Mechanisms

BER/Alarm/Alert Mechanism on a 3745 Down

Whenever a 3745 down condition is detected, there is a BER/alert/alarm generation mechanism started during the 3745 re-IPL initiated by the MOSS (see table hereafter). The possible causes of a 3745 down condition are:

- CCU hardcheck
- Hardware error
- Software error, hardware-detected
- Software error, software-detected.

Description	BER ID- Check- Ext field	Alert (m)	Alert (a)	Alarm (m)	Alarm (a)
IPL started	21-01	-	-	-	-
IPL completed W/O error	20-01	D0	-	D0	-
Re-IPL due to hardw. check, completed with error and dump	06-05-05	-	27	-	27
Re-IPL due to hardw. check, completed with error, no dump	06-05-05	-	20	-	20
Re-IPL due to softw. error, completed W/O error, with dump (depends on abend code)	06-05-07	-	41 42 47	-	41 42 47
Re-IPL due to force dump from VTAM	06-05-07	-	48	-	48
Re-IPL for CP abend	06-08-07	-	40	-	40
Re-IPL due to softw. error, completed OK, no dump	06-05-07	-	46	-	46
IPL/re-IPL completed with errors	06-03-01	D1	D1	D1	D1
IPL/re-IPL completed with error and dump	06-06-01	-	-	44	44
IPL/re-IPL completed with error, no dump	06-06-01	-	-	49	49

Figure 11-7. Alarm and Alerts Generated by IPL

Notes:

In the header of the above table:

- (m) means Manual
- (a) means Automatic

Analysis of a BER/Alarm/Alert Sequence

Any error detected by the MOSS during the re-IPL checkout tests, and during the re-IPL process is also logged between the BERs signalling the start and the end of re-IPL.

Also, any pending BER found by the MOSS in the CRP, is fetched and logged during re-IPL phase 1B.

Therefore, a typical sequence would appear like this, as seen on the BER file retrieval screen, option **all**:

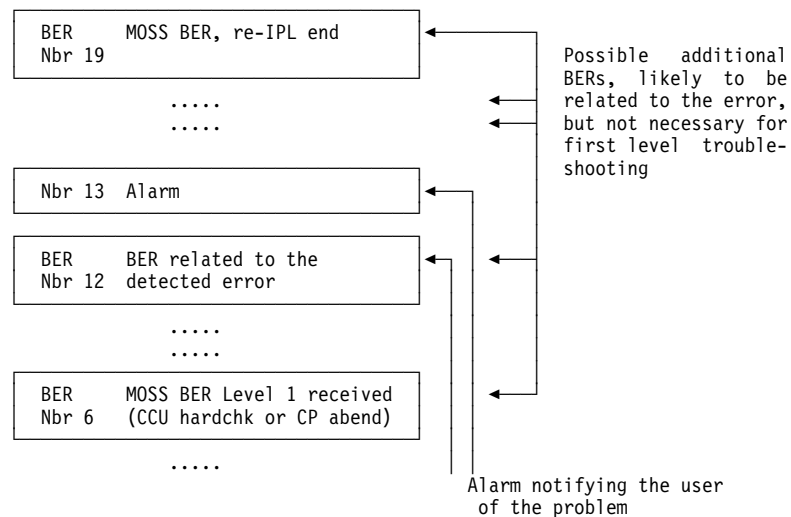

Figure 11-8. Example of a BER/Alarm/Alert Sequence

Note that BERs are displayed in inverted chronological sequence (most recent first).

BER Display

There are three kinds of BER display screens:

- ELD summary
- ELD list
- ELD detail.

When troubleshooting, you should normally display the ELD summary, then the ELD list, and last the ELD detail(s) pertaining to the fault. The BER display procedures and details are given in the *Service Functions* manual, SY33-2069.

Finding the Appropriate ELD Detail Screen

Use the following table to find the page for ELD detail screen explanations for a given BER type and BER ID. This table also shows whether the control program or the MOSS created the BER.

For software information on BERs originated by the NCP/PEP, refer to the associated product publications.

In the ELD detail screens of this chapter, 'hh..' represents an hexadecimal value, 'bbb..' a binary value.

<i>Table 11-5. References for ELD Detail Screen</i>			
Type	Meaning	Created by	Page Number
01	MOSS-related BERs	MOSS	11-39 to 11-96
	All IDs except: 91, B3, C1, C2	NCP/PEP	11-102
03	Diagnostic	MOSS	11-123
04	Power control	MOSS	11-125
08	ESS-related BER	NCP/PEP	11-137
09	3746-900-related BER	NCP/PEP	11-145
10	CA-related BER	NCP/PEP	11-169
11	TSS-related BER	NCP/PEP	11-184
12	NCP/PEP related BER	NCP/PEP	11-192
13	CCU-related BER	NCP/PEP	11-195
14	IOC-related BER	NCP/PEP	11-199
15	TRSS-related BER	NCP	11-203
02	A BER type 02 may appear on the ELD list file. It is the type for the alarms logged on the disk. This BER type must be ignored.		

Field Common to Many ELD Detail Screens: X'76' and X'76'U: The control program stores the error information in the IOC bus error register in X'76', in order to place its contents in the BER fields. If another IOC bus error occurs while filling in the BER fields, the contents of the IOC bus error register for the second error are placed in the X'76'U field of the IOC BER.

MOSS BER IDs List

<i>Table 11-6. List of BERs Built by the MOSS</i>			
Description	BER Type	BER ID	Refer to page
Level 0 error handler	01	00	11-39
Level 1 error handler	01	01	11-50
MCC error handler	01	02	11-53
DFA error handler	01	03	11-56
CCA error handler	01	04	11-60
MOSS/scanner	01	05	11-63 and 11-64
Events when no IPL	01	06	11-66
IPL Tasks	01	06	11-67
MOSS/TRSS	01	07	11-78
CADS dump function	01	08	11-80
Disk function	01	10 11 12	11-81 and 11-82
Keyboard function	01	13	11-82
MIOC function	01	14	11-82
Mailbox interface function	01	15	11-82
MOSS-CP Interface	01	16	11-83
RSF function	01	17	11-84
IML complete with error	01	19	11-85
MOSS-CP Interface	01	1A to 1D	11-83
IPL complete with error	01	20	11-86
Concurrent maintenance	01	24 to 29	11-94
Adapter error on diags	01	30	11-94
MCAD error	01	32	11-94
Cyclic hour notification	01	36	11-95
Concurrent maintenance	01	37 and 38	11-94 and 11-96
MMIO interface error	01	39	11-96
MOSS composite BER	01	85	11-30 and 11-117.
MOSS CP interface	01	91 B3 C1 C2	11-102

Note: The composite BER is displayed only in the ELD list. When you choose the SEL# of BER ID 85 you will see displayed the ELD detail screen of the last BER built by the MOSS.

Scrolling over the composite ELD detail, and using key F8 (F8: NEXT), you get only the last part of the composite BER whose description appears in the BER list. The other parts of the BER can be displayed using key F7 (F7: PREVIOUS) see page 11-30.

AutoMaint

AutoMaint Strategy

The automatic BER analysis (AutoBER) provides a **reference code** (see: "Reference Code Structure" on page 11-21). It identifies, either the faulty FRU(s), the software/microcode errors, or other error causes (for example, CP sysgen).

This reference code is sent both to the network console through alert and to the MOSS console through alarm. When the host operator receives it within the alert, the NetView panels or the *Problem Determination Guide (PDG)* for alarm, may ask him to contact the HCS/HSC, and to give them the reference code.

If NetView is not available, once the alert is received on VTAM it is logged on the LOGREC disk. In this case, the customer must consult the alarm displayed at the MOSS console.

The reference code is put in the header of the analyzed BER on disk, and:

- If an alarm must be generated, the reference code is appended to:
 - The alarm on disk, and
 - The alarm on the console.
- If an alert must be generated, the reference code is provided as one of the variable data.

Note: If alarms can always be generated when applicable, alerts need to have a CP loaded and operational to be transmitted from MOSS to NetView through NCP and VTAM. Then, it is not unusual to have some alarms with no alert.

In addition, for some specific cases, only a panel hexadecimal error code is available. Customers have to use the PDG, service personnel will refer to the MIP.

Using the ELD function, CEs and customers can have access to the complete list of alarms, BERs, reference code in the BER file itself, through the MOSS console.

In case of alarm, the CE can log specific information, which will be kept by the system (alarm).

This type of information can be useful to keep a history file of CE interventions.

The different alarms are identified through a two-digit hexadecimal value called the alarm number. When existing, related alert always carries this number through a field called Product Alert Reference Code, not to be confused with the Automaint Reference Code which appears in alert through a field called IBM 3745 Reference Code.

Alerts on NetView screens are generally self explanatory. Code points transmitted in Generic Alerts are translated by NetView into understandable text, except product variable data which is displayed as specified in alert. Then if the PDG gives the list of alerts with their contents, it is only for information to customers so

that they can prepare Clists for automated operations (for example, automatic resource reactivation after a successful error recovery).

Some BERs and related alarms/alerts have no reference code, as they are only reporting major events to the external world (no case of error, for example, CCU (re-)IPL complete, or scanner (re-)IML complete).

When applicable, a valid or meaningful reference code must be retrieved from previous BER(s) and related alarm(s). In the PDG and according to the alarm number, possible causes and recommended actions are given (as for alerts).

- The customer can fix the problem by himself (for example, CP sysgen error, modem power OFF...) or,
- The customer calls the IBM hardware central service (HCS) and gives the reference code and the alarm number.

Automatic BER Analysis

The analysis automatically starts when a BER occurs:

- It is called by the BER-logging task and processes the current BER just after it has been moved from the MOSS buffer into the sector image of the disk.
- It returns control to the logging task upon completion.
- Its purpose is to:
 - Build a reference code, according to the current BER contents and/or the contents of the BER file as output of an automatic correlation process.
 - Send this reference code to the MOSS console, within the ALARM.
 - Send this reference code to the host console, within the ALERT.
 - Write the reference code(s) within the BER and the alarm on the disk

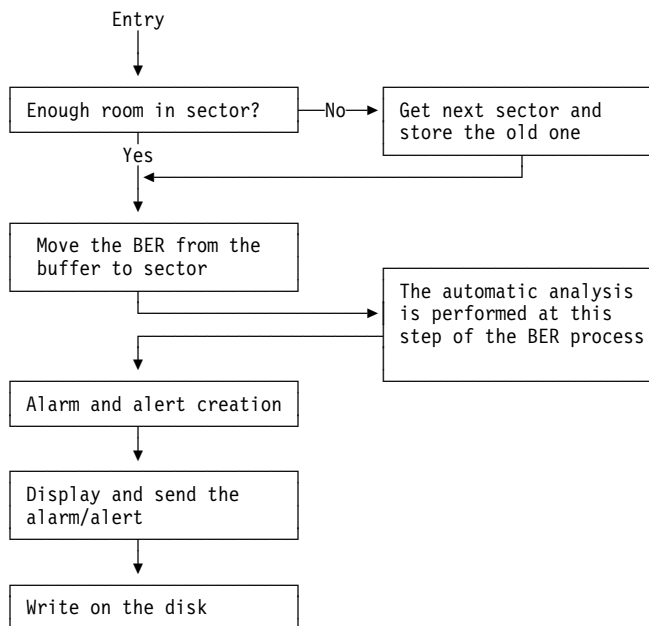

Figure 11-9. Automatic BER Analysis Process Flow

Note: Some BERs will never have an alarm/alert even if they get a reference code and only those reference codes in alarms/alerts must be considered first.

General Process Flow

The automatic BER analysis activates the following functions:

- Analysis of the type and ID of the current BER with either:
 - Direct translation of this BER into a reference code.
 - 'Other BER' analysis, when the last BER refers to another one.
 - Secondary field analysis. Analysis of fields other than type and ID, according to a decision table.
- Correlation with BERs generated before (see correlation process in the *Service Functions* manual).
- Logging of the collected information into the alarm and the alert.

All the information collected in the above steps is stored in a data block called interface block.

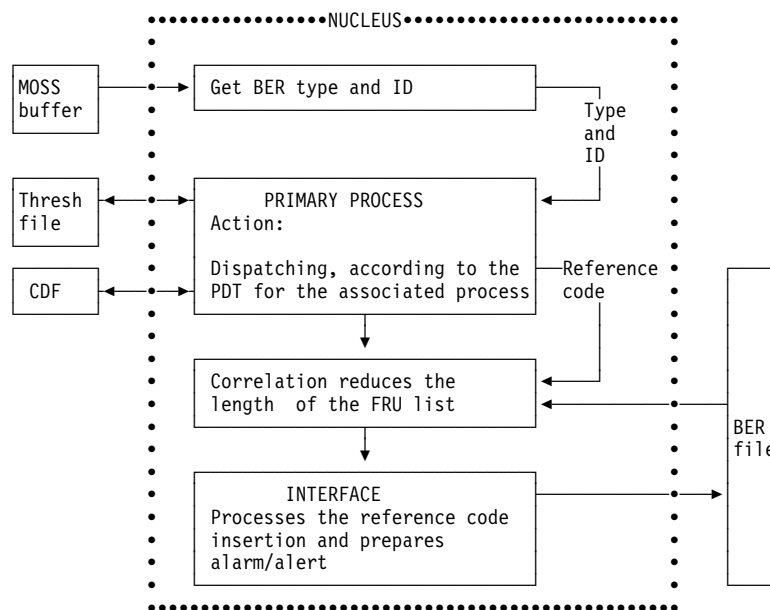

Figure 11-10. Automatic BER Analysis General Process

CE Field Updating

A 40-byte field (CE field), located at the end of the alarm, is made available to the CE so that he can leave some 'personal notes' for himself or for another CE.

Refer to the *Service Functions* manual, for description and updating of that field.

BER Reference Code

In case of a non-permanent failure, different BERs can be logged in the BER file at different times for this intermittent failure.

The automatic process gives, for each BER, a reference code pointing either at an FRU list, or a software/microcode problem. Then the network operator can call the HCS when too many hits occur in a given period.

When the CE arrives at the customer's site and diagnostics do not reproduce the error, the CE will first try to change the FRU(s) which has (have) been called previously (see reference code interpretation), but if this method fails (immediately or in the few days following this intervention), the CE or HCS/HSC will use the MOSS BRC function through RSF:

- **Reference Code Interpretation**

This function displays the FRU list and location, or the list of primary causes associated to a given reference code. It also displays additional information (other causes to be suspected).

Note: Reference code interpretation is also available through RETAIN/URSF and 3745 RDB.

- **Manual FRU Correlation**

Correlation over a user's defined range of BERs.

Correlation only applies to reference code pointing to hardware FRUs. It is only meaningful in the context of a single fault at a time.

Manual FRU Correlation

This procedure ignores the diagnostic BERs (BER type 03) reference codes.

This process correlates all FRUs called by reference codes in the range, to produce a list of suspected FRUs with a priority order based on occurrence times. This process is almost the same as the one described in the FRU correlation process of the automatic BER analysis. The only differences are:

- Manual correlation gives the complete ordered FRU list (by level of occurrence), rather than a reference code (given by the automatic correlation) pointing to the most probably failing FRU(s) (1 or 2).
- Manual correlation is done in a range of BER sequence numbers selected by the CE, whereas automatic correlation is done on a predefined time range.
- No alarm/alert is generated in manual correlation.
- No reference code is generated.

Thus, by looking at all BERs (with or without alarm) occurring at box malfunction time, additional FRU(s) to be suspected can be pointed out.

Procedure: The FRU correlation procedure is described in the *Service Functions* manual.

Automatic FRU Correlation

- **Triggering**

The correlation is started if:

- The current BER generates an alarm by itself, and
- The current BER is related to a hardware FRU list.

- **Correlation Range**

The correlation process is done starting from the current BER, and going back up to the BERs logged during the last three minutes, or to the end of the file if needed.

The objective is to reduce a list of three FRUs to either two FRUs or one FRU only (as the most probable cause). If successful, the produced Refcode will be of BX... type. Refer to Figure 11-14 on page 11-23.

Reference Code Structure

3745 reference codes are generated by the microcode which runs in the MOSS to provide an automatic analysis of box event records (BERs). The reference code has eight significant digits (D1 to D8).

According to the combinations of the values of:

- D1
- D2-D3

the other fields may provide different kinds of information. (See Figure 11-14 on page 11-23 after the 2 examples below).

Reference code related to a hardware problem:

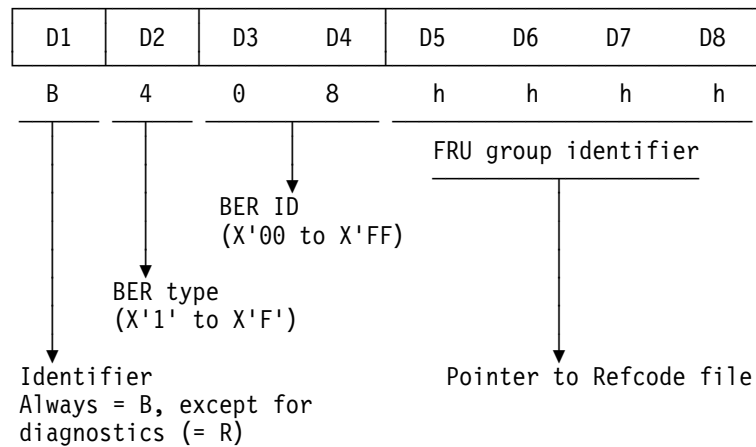

Figure 11-11. Example of a Power BER Type 4 ID 08

Reference code related to a multiple source problem:

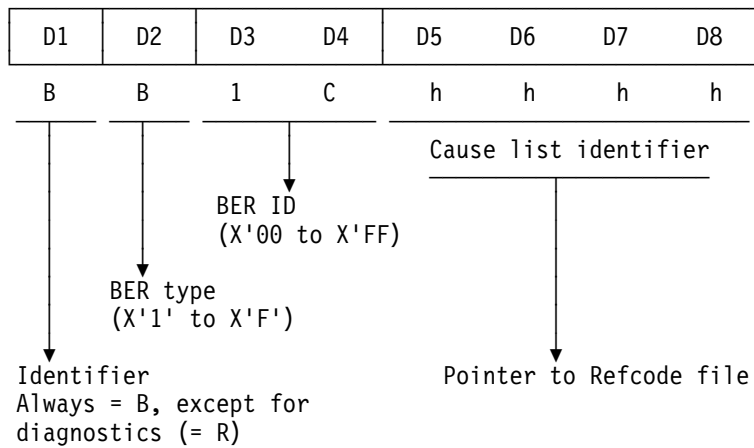

Figure 11-12. Example of a Power BER Type 11 ID 1C

Reference code related to a software/microcode problem:

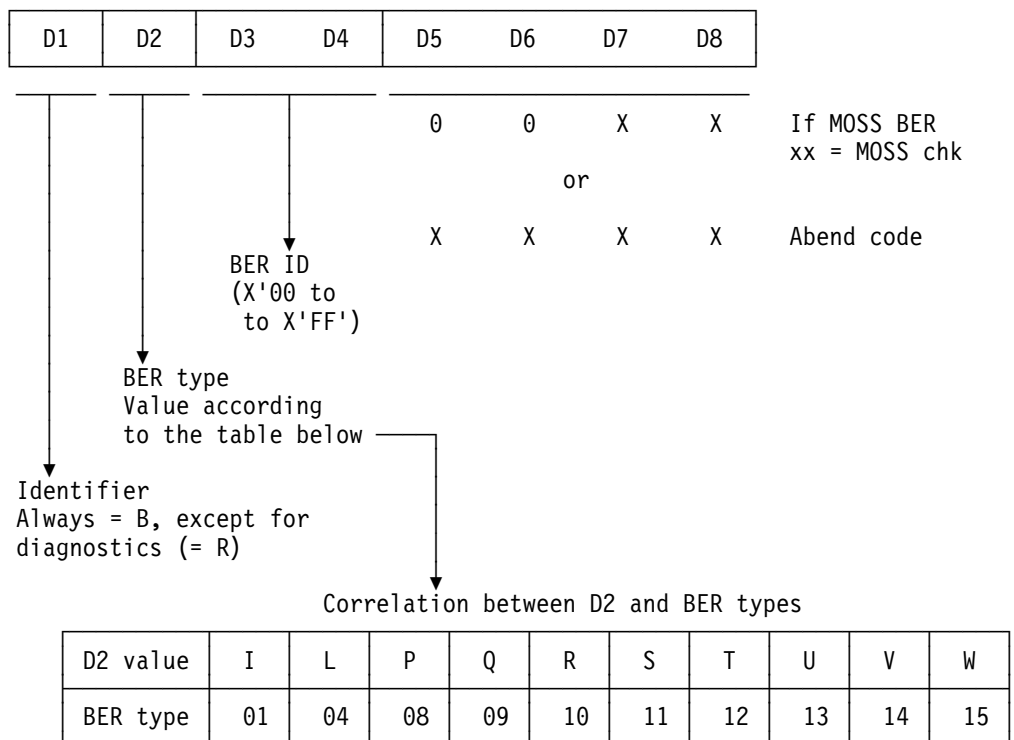

Figure 11-13. Example of a Software/Microcode Problem

Reference Codes.

D1	D2	D3	D4	D5	D6	D7	D8
B	1, 4 8, 9 A, B C, D E, F	ID		FRU GROUP Number			
B	G	Associated FRU indicator		FRU GROUP Number			
B	J	Type	ID	ADAPT Nb Note	ADAPT Nb	ADAPT Nb	
B	I, L P, Q R, S T, U V, W	ID		ABEND CODE or MOSS Check			
B	X	First FRU logical number			Second FRU logical number		
R	G	Associated FRUs		FRU logical number			
	H	Associated FRUs		INDEX 1	INDEX 2		
	3	ID		FRU GROUP number			
	K	ID		MOSS Check			
B	Z	Type	ID	X'F0F0F0' (no error)			
				X'F0F0F1' (Meaningless)			
				Program in error		Seq. Number	

- HARDWARE FRUs pointed - MAP

SOFTWARE/ MICROCODE error

AUTOMATIC FRU CORRELATION

DIAGNOSTICS

DUMMY

Figure 11-14. Reference Code Structure

Note: ADAPT Nb. is actually CA absolute number (displayable digit 0 to F).

The FRU list associated to a FRU group or the FRU associated to a logical number is found using the MOSS BRC function.

BER Recovery Procedures

Before being logged and stored on the disk, BERs are kept in MOSS and/or CCU storage. While in this transition stage, the BERs are volatile, and are lost if a power-OFF or power-ON reset occurs.

MOSS Handling of 3745 Down

The MOSS has stored a BER in the BER stack (in MOSS storage), but could not log it on the disk. In that case, MOSS will display the error code of the MOSS BER 01 ID 00. Display the BER using the procedure given in the *Service Functions*, SY33-2069. The remaining two digits may be interpreted by referring to page 11-40.

IOC Bus and Adapters

The following three BER types can occur for failures in this area:

- BER type 10

An error is detected while the control program is involved in a transaction with a channel adapter.

- BER Type 08/11

- An error is detected while the control program is involved in a transaction with a communication subsystem **and** the control program has identified the scanner concerned.
- A specific communication scanner reports an error to the control program.

- BER type 14

An error is detected while the control program is involved in a transaction with an adapter **and** no adapter can be identified as the source of the error.

Note: A single intermittent error can be reported as BER types 10, 11, or 14, depending on the time at which the error occurred, and the control program or microcode transaction that was taking place at that time. In this case, correlation may be useful to narrow down the range of possible failing components.

Scanner Errors Without BERs

Some errors in a communication scanner may not lead to a BER, although information within the scanner is available to help in fault isolation. Use the following procedure:

1. Start an internal or external SIT. Refer to the *3745 Service Functions*.
2. When the problem occurs, stop the SIT.
3. Analyze the SIT. Use the TSS services to display the scanner storage.

Unresolved Interrupts

The control program logs BERs based on 'unresolved situations' (see "BER/Alarm/Alert/Mechanisms" page 11-12).

Unresolved Level 1 CA Adapter Error (BER 10 ID 9E)

There are two possible types of unresolved CA level 1 interrupts.

- A CA level 1 occurs and no bit is ON in the CA external register X'E'.
- There is a CA level 1 and none of the following bits is ON in the CA external register X'D':
 - 0.0 IOC bus parity error
 - 0.1 internal bus parity error
 - 0.2 CCIN card check
 - 0.4 CHIN card check
 - 0.5 address compare error
 - 1.0 output exception check
 - 1.1 PIO halt remember latch
 - 1.2 cycle steal halt remember latch
 - 1.3 bus in check interface A
 - 1.6 CADR card check interface A

The following bits are checked in X'0'. If none is ON, the control program builds a BER 10 B1:

- 0.0 (normal) initial selection interrupt
- 0.1 interface disconnect
- 0.2 selective reset
- 0.3 channel bus out check
- 0.5 stacked initial status
- 0.6 ESC status byte cleared
- 0.7 system reset.

Unresolved Level 3 CA Data/Status (BER 10 ID B2)

The following bits in are checked in X'2'. If none of these bits is set and the system reset bit in X'0' is not set (bit 0.7), the control program builds a BER 10 B2:

- 0.0 outbound data transfer sequence
- 0.1 inbound data transfer sequence
- 0.2 (final) status transfer sequence
- 0.5 channel stop/interface disconnect
- 0.6 suppress out monitor interrupt
- 1.1 data/status selective reset
- 1.3 stacked ending status.

Unresolved Level 3 CA Interrupt

If, in NCP/EP/PEP, there is no CA control block that has selected bits matching those of the interrupting CA, then a BER 10 33 is built.

Scanner, TSS, or ESS AIO Unresolved Errors (BER 08 ID 92, BER 11 ID 92)

- In X'7E', bit 0.7 (IOC level 1 summary) is ON.
- In X'76', bit 0.6 (adapter-initiated operation) is ON.
- In X'75', bit 0.0 (AIO CSCW) is ON.

Then, following the IOH to read the error status, one of the following bits is ON in X'76':

- 0.4 IOC time out.
- 0.5 IOC bus in parity error.

Scanner, TSS, or ESS Adapter Unresolved Error (BER 08 ID 9A, BER 11 ID 9A)

- In X'7E' bit 0.5 IOC adapter level 1 request.
- The error status returned an IOH read error status command = 0.

Scanner, TSS, or ESS Level 2 Unresolved (BER 08 ID A1, BER 11 ID A1)

There are 3 types of unresolved/undefined interrupts:

- A level 2 interrupt that occurs on a non-SYSGENed line.
- A level 2 interrupt from a SYSGENed line with the SCF, SES, and LCS all zero.
- A level 2 interrupt from a SYSGENed line, but the received status does not match the expected one.

CCU Level 1 Unresolved Interrupts (BER 13 ID 91)

The following bits are checked in X'7E'. If none is set, the control program builds a BER 13 91:

- 0.0 MOSS inoperative
- 0.1 any CCU hard error
- 0.3 level 5 I/O error
- 0.4 invalid operation
- 0.5 IOC adapter level 1 request
- 1.0 address compare level 1
- 1.1 address exception I fetch
- 1.2 storage protect I fetch
- 1.3 address exception program execution
- 1.4 storage protect program execution
- 1.6 IPL level 1 request.

CCU Level 3 Unresolved Interrupt (BER 13 ID B1)

This condition occurs in three different environments:

- NCP only
- PEP
- Remote NCP (from the host standpoint)

The checks are then different.

- **NCP Only**

The following bits are checked. If none of them is set, the control program builds a BER 13 B1:

- X'77' bit 1.0 CA level 3 interrupt
- X'77' bit 1.1 CA level 3 interrupt
- X'F' bit 0.2 CA level 3 initial selection request
- X'F' bit 0.3 CA level 3 data/status request
- X'7F' bit 0.6 user interrupt request level 3
- X'7F' bit 1.5 internal timer interrupt level 3
- X'7F' bit 1.6 PCI level 3.

- **PEP**

The following bits are checked. If none of them is set, the control program builds a BER 13 B1:

- X'F' bit 0.2 CA level 3 initial selection request
- X'F' bit 0.3 CA level 3 data/status request
- X'7F' bit 0.6 user interrupt request
- X'7F' bit 1.5 internal timer level 3
- X'7F' bit 1.6 PCI level 3.

- **Remote NCP**

If X'77' bit 1.0 or bit 1.1 is set, and none of the following bits is set, the control program builds a BER 13 B1:

- X'7F' bit 0.6 user interrupt request
- X'7F' bit 1.5 internal timer level 3
- X'7F' bit 1.6 PCI level 3.

A BER 10 B7 is built if:

- X'77' bit 1.0 or bit 1.1 is reset, and
- CA is attached and installed (not defined).

Otherwise, a BER 13 32 (level 3 interrupt configuration check) is built.

CCU Unresolved Level 4 Router (BER 13 IDs C1/C2/C3)

Two conditions may be detected by the level 4 router:

- General unresolved condition
- Unresolved with respect to a PCI Level 4.
- **General Unresolved Condition**

If none of the following bits is set in the X'7F' when a level 4 interrupt occurs, the control program builds a BER 13 C1:

- X'7F' bit 0.3 MOSS request service
 - X'7F' bit 0.4 MOSS response service
 - X'7F' bit 0.7 PCI level 4 interrupt
 - X'7F' bit 1.7 service request.
- **Unresolved Level 4 PCI**
- The control program builds a:
- BER 13 C2 if X'7F' bit 0.7 is set, and no reason byte is set in the level 4 router control block.
 - BER 13 C3 if the control program cannot reset the level 4 PCI latch.

Unresolved IOC Bus Errors (BER 14 IDs 91/92)

- **Unresolved Adapter Level 1 (BER 14 91)**
 - In X'7E' bit 0.5, IOC adapter level 1 request, is ON.
 - Following an IOH broadcast poll command to identify the board with the adapter problem, X'7E' bit 0.7, IOC level 1 summary, is ON.
- **Unresolved AIO Level 1 (BER 14 92)**
 - X'7E' bit 0.7, IOC level 1 summary, is ON.
 - X'76' bit 0.6, adapter initiated operation, is ON.
 - X'75' is invalid. This is true when:
 - **Either**
 - X'76' bit 0.2, (IOC invalid CSCW) is ON
 - **Or**
 - X'76' bit 0.4, (IOC timeout) is ON
 - and** IOC status (X'76' bits 0.0 to 0.3) = 2.
 - (No response to TA tag or cycle steal grant.
 - **Or**
 - X'76' bit 0.5 (IOC bus IN parity error) is ON
 - and** IOC status (X'76' bits 0.0 to 0.3) = B.
 - (Loading the CSCW).
- **Unresolved PIO Level 1 (BER 14 93)**
 - X'7E' bit 0.7 (IOC level 1 summary) is ON.
 - X'76' bit 0.6 (adapter-initiated operation) is OFF.
 - X'76' bits 0.4 (IOC time out) and 0.5, (IOC bus in parity error) are OFF.

MOSS Error Logging

Hexadecimal Codes

During MOSS IML, hexadecimal codes appear on the operator's panel. They are either progression codes (events), or errors.

Hexadecimal codes and BERs: The hexadecimal codes may be related to a BER. In other cases, a BER is created when the hexadecimal code is displayed.

The connection between the hexadecimal code and the BER may be done by using the time stamp (indicating when the BER was built), and by the field **hexa display** bytes 34 and 35 of MOSS BER foM0 page 11-112. For error decoding, see "MOSS Check Error Decoding" on page 11-30.

Hex codes	Meaning	Action	Ber created	Type of info
001-04F	Power errors		NO	
050-17F	Error during ROS/Storage/DFA diags		NO	
180-1FE	Error during diags in RAM MOSS test		NO	
1FF	MOSS storage diag OK		NO	
Axx-Bxx	IML stop on error (doesn't force re-IML)	MOSS level 0 interrupt	ID 00	
Cxx	MOSS re-IML threshold reached (xx MOSS IML attempts within a given period of time)	MOSS level 0 interrupt	ID 00	
D00-DFE	IML stop on disk/diskette error (doesn't force re-IML) (D00 = MOSS dump complete)	MOSS level 0 interrupt	ID 00	
	MOSS level 0 re-entry (re-IML)	MOSS level 0 interrupt		
	MOSS level 0 re-entry while in re-IML	MOSS level 0 interrupt		
F00	Start of MOSS dump			
F01	MOSS dump complete			
F10-F61	IPL check		ID 00 ERR 06	Code to suspected FRU list
FEx	IML complete with error		ID 19	
FFA	Status progression steps which occur during the IPL sequence. IPL has com- pleted but has detected a PCA1 adapter error. Local console may not be acces- sible.		ID 06 ERR 03	
FFE	IPL complete with error		ID 06 ERR 03	
FFF	IPL canceled after error detection		ID 06 ERR 06	

Hexadecimal Codes Versus MOSS BER ID 00

When a blinking hexadecimal code is displayed, it means that the MOSS was unable to build the corresponding BER. The information concerning this BER can be found if the function DDD (dump, display, delete) is used with the address given by the parameter 'CHGHVBER', see *Service Functions*. (See "BER TYPE 01 ID 00 Error Code Description" on page 11-40 for details).

MOSS Check Error Decoding

All the MOSS check codes described in the list on Table 11-11 on page 11-40 have the following decoding.

When the faulty FRU or FRUs given by the hexadecimal code list in the 3745 MIP is exhausted and the error persists, or is transient (intermittent), it is advisable to analyze the corresponding BER, if any.

In the MOSS BER ID 00, the contents of the **MOSS check** field (see: Figure 11-14 on page 11-23) is very helpful to analyze the error. The figure below shows the information provided in this field. Alert/alarm 02 indicates that during the error, a re-IML is performed and a dump is taken.

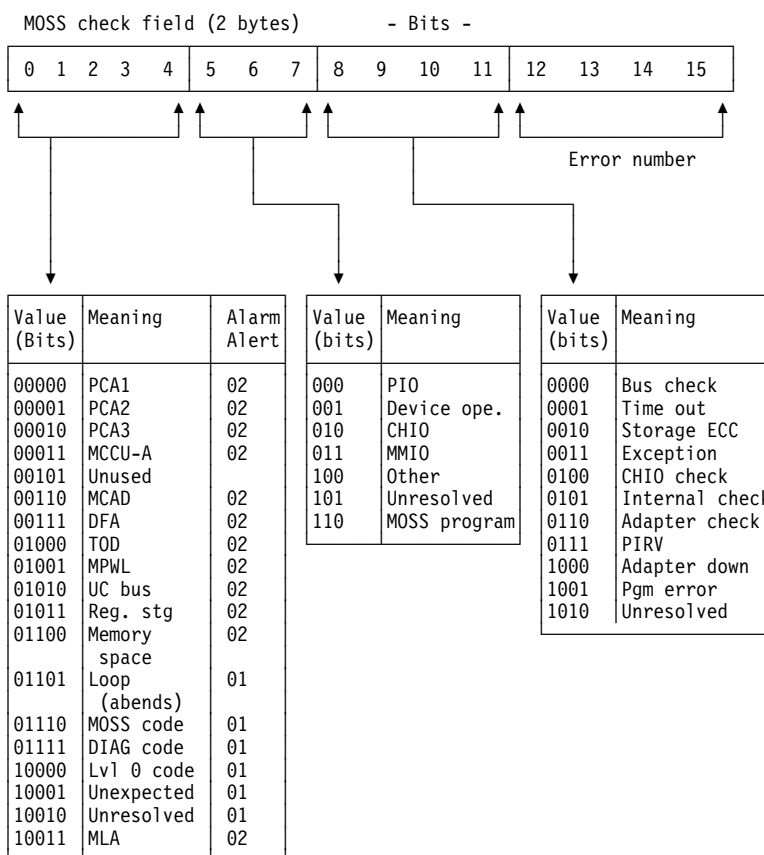

Figure 11-15. Decoding of the MOSS Check Field

Composite BER

The MOSS stacks all BERs which can be produced all along a given request, in a composite BER (type 01 ID 85) and only the last BER stacked asks for the queueing in the BER buffer pool. The composite BER is a variable-byte buffer (see page 11-117).

Scrolling over a composite ELD detail, and using the key F8 (F8: NEXT), you get only the last part of the composite BER whose description appears in the ELD list. The other parts of the BER can be displayed using the F7 key (F7: PREVIOUS).

Four cases lead to a BER reporting activity:

1. A MOSS function requests an I/O operation, and a hardware error is reported to the level 0 of the adapter code, and finally, to the task itself.

The selected command sets a pointer to the composite BER buffer, clears the data area, initializes the composite BER header and sends the I/O request. When the I/O error is reported to the level 0 of the MOSS control code, and only when that error is not recoverable, the level 0 identifies the failing adapter, and stacks the BER (Type 01 ID 00).

The level 0 control code then schedules the machine check information of the adapter. According to the kind of event or error, one of the following BERs is created:

- Moss/MCC HLIR Type 01 ID 02
- Moss/MCC CAC Type 01 ID 02
- Disk file adapter CAC Type 01 ID 03
- Keyboard display adapter ... Type 01 ID 04

The MOSS gets control back at the end of the invoked command and calls, when an error is found, a control code function which stacks a second BER according to the called function:

- Disk function Type 01 ID 10, 11, 12
- MOSS console Type 01 13
- MIOC function Type 01 14
- Mailbox interface function.. Type 01 15
- MOSS-CP interface Type 01 16
- RSF MOSS function Type 01 17

Then this function queues the composite BER in the buffer pool. The composite BER may contain a variable number of BERs, but usually, it contains three BERs.

Composite BER (Type 01, ID 85) example: If a MOSS level 0 occurs during a disk I/O operation related to a LOAD request from an application, a BER 01 85 is logged. (Assume that, for this example, it is **SEL# 233**). This BER contains:

- SEL# 233.3 BER 01 11 Disk adapter
- SEL# 233.2 BER 01 03 CAC
- SEL# 233.1 BER 01 00 Level 0

A selection number for a BER 01 85 is displayed with the event description related to the latest BER put into the BER 01 85. You may scroll from the ELD detail screen to display the other BERs contained in BER 01 85 using **F7: PREVIOUS**.

In the example above, the event description first displayed on the ELD detail screen for SEL# 233 will refer to SEL# 233.3 BER 01 11.

- Pressing 'F7: PREVIOUS' will display SEL# 233.2 BER 01 03.
- Pressing 'F7: PREVIOUS' a second time will display SEL# 233.1 BER 01 00.

If you scroll forward to SEL# 233 from SEL# 232 using 'F8: NEXT', the first detail displayed is SEL#233.3. You must then use 'F7: PREVIOUS' to display SEL# 233.2 and SEL# 233.1 as described above.

2. A MOSS function has requested an I/O operation and a hardware error is reported to the adapter code and finally to the task itself.

This case is basically identical to case 1 except for level 0 processing. In the above case, the composite BER contains two BERs.

3. No active MOSS function requests an I/O operation, but a hardware error is reported to MOSS level 0 and to the adapter code. Level 0 handles the process and uses its own composite BER buffer. The machine check microcode queues the composite BER in a buffer. In this case, the composite BER contains two BERs.

4. No active MOSS function requests an I/O operation, but a hardware error is reported to the adapter.

This case is basically identical to case 3 except for the level 0 processing. In this case, the composite BER contains one BER. The composite BER process is automatically done by the microcode.

MOSS BERs Used With the IPL Application

The following BERs are used by MOSS in connection with an IPL application:

ID	Error code	Ext.	Description	Format.
06	03	01	IPL complete + errors (1)	FoM6
	06	01	IPL check	"
	05	05	CCU hardcheck as alert support	FoM19
	05	07	Program request as alert support	"
	08	05	CCU hardcheck as alarm support	FoM9
	08	07	Program request as alarm support	FoM19
	09		CLDP abend as alarm support	FoM10
20	01		IPL complete without errors	FoM21
21	01		IPL started	FoM23

Note: (1) Non-blocking errors.

MOSS BER Type 01 - Summary

BER ID	MOSS Chk code	BER Add Fid	Event Description	Recovery or PGM Action	ALERT	ALARM
00			See MOSS-CHECK code for software error See MOSS-CHECK code for hardware error		01 02	01 02
01	01		See MOSS 01 ID 01 field description	MOSS retry	NO	NO
01	02		See MOSS 01 ID 02 field description	MOSS retry	NO	NO
01	02		IOC operation error during MIOH (CCU to MOSS status A register, X'11', bit 0)	MOSS retry	NO	NO
01	02		IOC operation error (limit threshold)	MOSS down	NO	03
01	03		Adapter clock check (MCC status register 2, bit 4)	MOSS retry	NO	NO
01	03		Adapter clock check (limit threshold)	MOSS down	NO	03
01	04		CCU clock check (MCC status register 2, bit 3)	MOSS retry	NO	NO
01	04		CCU clock check (limit threshold)	MOSS down	NO	03
01	05		CCU hardcheck detected (CCU to MOSS status A register, X'11', bit 6). Upon detection of this event, MOSS will automatically start a CCU automatic re-IPL. See Specific Mechanism, page 11-12	NCP re-IPL		
01	07		MOSS TRSS interface		NO	NO
01	08		CADS dump function		NO	NO
01	09		Address exception check in CCU (CCU to MOSS status A register, X'11', bit 5)	MOSS down	NO	03
01	0A		MOSS/MIOC operation check, CCU detected (CCU to MOSS status A register, X'11', bit 7)	MOSS down	NO	03
02	any		CCU logical interface	MOSS down	NO	03

MOSS BER

Table 11-9 (Page 2 of 6). MOSS BER Type 01 Summary

BER ID	MOSS Chk code	BER Add Fld	Event Description	Recovery or PGM Action	ALERT	ALARM
02	any		CCU logical interface	MOSS fnct message	NO	NO
03	any		Disk drive and/or adapter error CNT=10 DEVICE CODE=X'02', X'04', X'06'	MOSS inop	07	07
03	any		Diskette file error CNT not 10 and DEVICE CODE = X'07'	MOSS inop	06	06
03	any		Disk drive and/or adapter error CNT = 10 and DEVICE CODE = X'01'	MOSS inop	04	04
03	any		Disk file error CNT not 10 and DEVICE CODE = X'03', X'05'	MOSS inop	05	05
04	0A		Local console CAC detected exception interface	Console not available	0A	0A
04	0C		Local console CAC detected error (interface)		0A	0A
04	40		Local console error (device) (CCA basic status register bits 4 and 5)		0B	0B
04	8A, 8C		Remote console interface error		0C	0C
04	C0		Remote console error (device)		0D	0D
05	F0		MOSS-scanner interface error. Soft re-IML OK, dump OK. Error detected by MOSS levels 1 or 4, when communicating with a scanner: <ul style="list-style-type: none"> MCC status register 1, bit 6, at level 4 CCU to MOSS status A register X'11' bit 0 	MOSS fnct message	61	61
05	F0		MOSS-scanner interface error. Soft re-IML OK, dump KO. Error detected by MOSS levels 1 or 4, when communicating with a scanner: <ul style="list-style-type: none"> MCC status register 1, bit 6, at level 4 CCU to MOSS status A register X'11' bit 0, and X'76' bits 0.6 or 0.7, at level 1 	MOSS funct. message	65	65
05	F0		MOSS-scanner interface error Soft re-IML KO, dump OK. Error detected by MOSS levels 1 or 4, when communicating with a scanner: <ul style="list-style-type: none"> MCC status register 1, bit 6, at level 4 CCU to MOSS status A register X'11' bit 0, and X'76' bits 0.6 or 0.7, at level 1 	MOSS funct. message	TSS: 62 HPTSS: 72	TSS: 62 HPTSS: 72
05	F0		MOSS-scanner interface error Hard re-IML OK, dump OK. Error detected by MOSS levels 1 or 4, when communicating with a scanner: <ul style="list-style-type: none"> MCC status register 1, bit 6, at level 4 CCU to MOSS status A register X'11' bit 0, and X'76' bits 0.6 or 0.7, at level 1 	MOSS funct. message	67	67
05	F0		MOSS-scanner interface error Hard re-IML OK, dump KO Error detected by MOSS levels 1 or 4, when communicating with a scanner: <ul style="list-style-type: none"> MCC status register 1, bit 6, at level 4 CCU to MOSS status A register X'11' bit 0, and X'76' bits 0.6 or 0.7, at level 1 	MOSS funct. message	68	68

Table 11-9 (Page 3 of 6). MOSS BER Type 01 Summary

BER ID	MOSS Chk code	BER Add Fid	Event Description	Recovery or PGM Action	ALERT	ALARM
05	F0		MOSS-scanner interface error Hard re-IML KO, dump OK. Error detected by MOSS levels 1 or 4, when communicating with a scanner: <ul style="list-style-type: none">MCC status register 1, bit 6, at level 4CCU to MOSS status A register X'11' bit 0, and X'76' bits 0.6 or 0.7, at level 1)	MOSS funct. message	TSS: 6B HPTSS: 72	TSS: 6B HPTSS: 72
05	F0		MOSS-scanner interface error. Hard re-IML KO, dump KO. Error detected by MOSS levels 1 or 4, when communicating with a scanner: <ul style="list-style-type: none">MCC status register 1, bit 6, at level 4CCU to MOSS status A register X'11' bit 0, and X'76' bits 0.6 or 0.7, at level 1.	MOSS funct. message	TSS: 66 HPTSS: 72	TSS: 66 HPTSS: 72
06	01		BER file deleted (via MOSS command)	File purged	NO	NO
06	02		BER stack overflow in MOSS storage.(MOSS maintains a 5K-bytes buffer to stack incoming BERs, before logging on)		NO	NO
06	03	01	IPL complete with errors. Some errors do not prevent the completion of IPL: <ul style="list-style-type: none">Scanner not IMLed successfullyBad parameters passed by control programErrors in CA monitoring taskError, found on the diskette, which is not detrimental for the IPLConsole or console adapter error Corresponding BERs are in the BER File. There is a message on the console.	IPL completion	D1	D1
06	04		LAXx (Lines xxxx-yyyy) IML failed		6A	6A
06	05	05	NCP re-IPL end and no dump MOSS creates this entry to end the re-IPL and generates the alert reporting the error which caused the re-IPL. CCU hardcheck BER as alert support (see Specific Mechanism, page 11-12)		20	20
06	05	05	NCP re-IPL end and dump MOSS creates this entry to end the re-IPL and generates the alert reporting the error which caused the re-IPL. CCU hardcheck BER as alert support (see Specific Mechanism, page 11-12)		27	27
06	05	07	NCP re-IPL end and no dump. MOSS creates this entry to end the re-IPL and generates the alert reporting the error which caused the re-IPL. CCU re-IPL on program request (see Specific Mechanism, page 11-12)		46	46
06	05	07	NCP re-IPL end and dump, and ABENDs : 910, 911, 930, 931. MOSS creates this entry to end the re-IPL and generates the alert reporting the error which caused the re-IPL. CCU re-IPL on program request (see Specific Mechanism, page 11-12)		41	41

MOSS BER

Table 11-9 (Page 4 of 6). MOSS BER Type 01 Summary

BER ID	MOSS Chk code	BER Add Fid	Event Description	Recovery or PGM Action	ALERT	ALARM
06	05	07	NCP re-IPL end and dump and ABENDs : 912, 915 (mismatch sysgen/re-IPL). MOSS creates this entry to end the re-IPL and generates the alert reporting the error which caused the re-IPL. CCU re-IPL on program request (see Specific Mechanism, page 11-12)		42	42
06	05	07	NCP re-IPL end and dump, other abends. MOSS creates this entry to end the re-IPL and generates the alert reporting the error which caused the re-IPL. CCU re-IPL on program request (see Specific Mechanism, page 11-12)		47	47
06	05	07	NCP re-IPL end and dump, ABEND 7FFF. MOSS creates this entry to end the re-IPL and generates the alert reporting the error which caused the re-IPL. CCU re-IPL on program request (see Specific Mechanism, page 11-12)		48	48
06	06	01	IPL complete with check, hardware cause. The MOSS microcode action is dependent upon the kind of NCP IPL or IML error found, see hexadecimal display. IPL check Fxx		NO	25
06	06	01	IPL complete with errors, dump on disk. The MOSS microcode action is dependent upon the kind of NCP IPL or IML error found, see hexadecimal display. IPL check Fxx		NO	44
06	06	01	IPL complete with errors, no dump on disk The MOSS microcode action is dependent upon the kind of NCP IPL or IML error found, see hexadecimal display. IPL check Fxx		NO	49
06	07		MOSS offline request by operator	MOSS offline	B7	B7
06	08	05	NCP re-IPL for CCU hardcheck. CCU to MOSS status A register, bit 6. See BER 01 01 05 which precedes it. This BER allows the MOSS to create an alarm. See Specific Mechanism, page 11-12	IPL process phase 1B	NO	24
06	08	07	NCP re-IPL for control program abend. Control program abend, no BER in CRP (ext register X'79' bit 0.2, raising CCU to MOSS register X'11' bit 1 in MOSS). See BER 01 01 07 which precedes it. This BER allows the MOSS to create an alarm. See Specific Mechanism, page 11-12	IPL process phase 1B	NO	40
06	09		CLDP check. (Output X'70' with cause of check in external register X'72' bytes 0 and 1). Hex display indication at control panel.	IPL stopped	NO	D2
06	13		Timed IPL will occur soon		NO	D9
06	14		Timed IPL is cancelled		NO	D8
06	18		LSSD string first part		NO	NO
06	28		LSSD string second part		NO	NO
07			TRSS MOSS BER		NO	NO
08			Error on MOSS/TRSS interface		NO	NO

Table 11-9 (Page 5 of 6). MOSS BER Type 01 Summary

BER ID	MOSS Chk code	BER Add Fld	Event Description	Recovery or PGM Action	ALERT	ALARM
10			DISK macro		NO	NO
11			DISK macro		NO	NO
12			DISK macro		NO	NO
13			KBD macro		NO	NO
14			MIOC function, MOSS to CCU		NO	NO
15			Mailbox in request		NO	NO
16			CCU buffer request		NO	NO
17			RSF BER (See Specific Mechanism, page 11-12)		NO	NO
18			Scanner re-IMLed successfully		09	NO
19			MOSS IML successful or with non-blocking errors		0F	0F
1A			CHIO		NO	NO
1B			Power error		NO	NO
1D			MCAD adapter error		NO	NO
1E			LAN handler check		NO	NO
20	01		IPL completed with error		D0	NO
21	01		IPL started		NO	NO
23			37CS RE-IML complete		13	13
24			Concurrent maintenance started		C0	C0
25			Concurrent maintenance ended		C1	C1
26			Concurrent maintenance cancelled		C2	C2
27			Concurrent maintenance rejected due to traffic		C3	C3
2A			ESCA RE-IPL failed		14	14
2B			See ORIGIN field page 11-93.			
2C			DL2 call completion		NO	NO
2D			CP dump transfer error. Dump purged		NO	NO
2E			3746-900 general IML		6C	NO
2E			LAN selective IML		6C	NO
2E			ESCA selective IML		6E	NO
30			MOSS warning adapter(s) during IML		NO	NO
32			MOSS MCAD error		02	02
36			Cyclic hour notification		NO	NO
38			Concurrent maintenance NCP request to cancel		C7	C7
39			MMIO interface error		AB	AB
41			Repair action started		NO	NO
42			Repair action end		NO	NO
43			IML data for non-blocking errors		NO	NO
44			MOSS code data for problem isolation		NO	NO
50			Remote console rejected		10	10
85			Composite BER is handled for each BER		NO	NO

Table 11-9 (Page 6 of 6). MOSS BER Type 01 Summary

BER ID	MOSS Chk code	BER Add Fid	Event Description	Recovery or PGM Action	ALERT	ALARM
91			<p>Level 1 interrupt MOSS down passed to control program by MOSS (MCC status reg 1, bit 3 giving a X'7E' input register bit 0.0 in the CCU)</p> <p>BER built by control program, and saved in the CRP. If this BER is in the diskette BER file, it means that it has been passed to the MOSS, when the MOSS was re-IMLed and set online.</p> <p>Reason for MOSS down might be found in the BER file itself, by looking at other BERs built by the MOSS, which triggered the MOSS inop bit in MCC status register.</p>	MOSS down	03	NO
A0			MOSS/MOSS-E token ring adapter error	NO	NO	
A1			MOSS/MOSS-E link lost		11	11
A2			MOSS/MOSS-E link re-opened		12	12
A3			MOSS transient error		NO	NO
A4			See page 11-106 for details.		NO	NO
B3			CP/MOSS connection OUT mailbox command. Time out at level 3 in control program	MOSS down	03	NO
C1			CP/MOSS connection OUT mailbox request error at level 4 in control program	MOSS down	03	NO
C2			CP/MOSS connection IN mailbox command error at level 4 in control program	MOSS down	03	NO

MOSS BER Type 01 ID 00 (Detailed BER Display)

BER format foM0: see page 11-112. MOSS microcode level 0 generates 3 displays. They consist in a fixed part and a part which displays the fields concerned by the type of error.

Fixed part

```

                                ELD DETAIL
SEL#:hhhh  FLAG:hh DATE:dd/dd TIME:dd:dd TYPE:00 ID:hh<LOST:ddd CP-ABEND:hhhh>
<ERROR DESCRIPTION>                                <REF. CODE IN CHAR.> CCCCCCCC
MOSCHK:hhhh CPLLPL:hh CM:hh MM:hh CHM:hh CHCV:hhhh CHIOP:hhhhhhhh
MODULE:hhhhhhhh DUMP:hh hh IA:hhhhhhhh MS:hhhhhhhh RS:hhhh
DIV:hhhh EIRV:hh IOIRV:hh PIRV:hh PSCI:hhhhhhhh OP:hhhhhhhh

REGS:hhhhhh hhhhhh hhhhhh hhhhhh hhhhhh hhhhhh hhhhhh hhhhhh
      hhhhhh hhhhhh hhhhhh hhhhhh hhhhhh hhhhhh hhhhhh hhhhhh

(Here are displayed the two lines of the changing part - group 1, 2
or 3- the groups are described below)

.....
.....
    
```

Changing Part of MOSS BER Type 01 ID 00

1. Errors about the PCAs (hex codes A01-A0F), the DFA or TOD (hex codes A8D, AAA, and Dxx), and MOSS BER Type 01 ID 80:

```

DFA:hh hh hh TOD:hh
PCA1:hh hh hh hh hh PCA2:hh hh hh hh hh PCA3:hh hh hh hh hh
    
```

2. Errors about the MCCU-A (hex codes A10 to A83):

```

MCCU A:hhhh hhhh hhhh hhhh hhhh hhhh SWAD: 0000 (not used)
    
```

3. Errors about the MCAD, without any register displayed (hex codes A84 to A8C, and AAB to CFF):

```

MCAD:hh hh hh hh hh hhhh hh hhhh hh
SNAP:hhhhhhhh hhhhhhhh hhhhhhhh hhhhhhhh hhhhhhhh hhhhhhhh hhhhhhhh
    
```

4. MLA error (hex code AE8 to AEB)

```

MLA:hhhhhhhh hhhh
    
```

MOSS BER Type 01 ID 00 - Field Description

Table 11-10 (Page 1 of 2). MOSS BER Type 01 ID 00 Field Description		
Field Name	Meaning	Refer to
MOSS-CHECK	MOSS error code.	Page 11-40
EIRV	Error interrupt request vector	Page 11-44
DIV	Diagnostic information vector	Page 11-44
IOIRV	I/O interrupt request vector	Page 11-44
PIRV	Program interrupt request vector	Page 11-44
CPLLPL	Current/last priority level	Page 11-44
CM	Common mask	Page 11-44
MM	Master mask	Page 11-44
CHM	Channel mask	Page 11-44

Table 11-10 (Page 2 of 2). MOSS BER Type 01 ID 00 Field Description

Field Name	Meaning	Refer to
CHCV	Channel control vector	Page 11-45
IA	Instruction address of the last level interrupted by level 0	Page 11-45
PSCI	Program status code indicator of the interrupted level	Page 11-45
LOPC	Last operation code.	Page 11-45
MS	Main storage address (parity detected)	
RS	Register storage address (parity detected in MSC)	
OP	Op code at error time	
SNAP	Snapshot dump	Page 11-49
STAT CNT	Error count for each adapter	
CHIOF	CHIO pointer register (current)	
DUMP	Dump/IML request	Page 11-46
EIRV1	EIRV in case of MOSS level 0 re-entry.	Page 11-44
IOIRV1	IOIRV in case of MOSS level 0 re-entry	Page 11-44
PIRV1	PIRV in case of MOSS level 0 re-entry	Page 11-44
DIV1	DIV in case of MOSS level 0 re-entry	Page 11-44
LOPC1	Last operation code (level 0 re-entry)	Page 11-44
PCA1	PCA1 status registers	Page 11-48
PCA2	PCA2 status registers	Page 11-48
PCA3	PCA3 status registers	Page 11-48
MCCU-A	MCCU-A status registers	Page 11-46
SWAD	Not used	
MCAD	MCAD status registers	Page 11-47
DFA	DFA status registers	Page 11-49
TOD	TOD status register	Page 11-49
REGS	MOSS processor registers	Page 11-46
MLA	MOSS LAN adapter (only for MOSS check 9800)	page 11-49

BER TYPE 01 ID 00 Error Code Description

The encoding of the MOSS-CHECK bytes is explained on page 11-30.

Table 11-11 (Page 1 of 4). MOSS BER Type 01 ID 00 Error Codes Description

Field Name	Hexa Code	MOSS Check Code (Hexa)	Description
PCA1	A01	0580	Adapter down
	A02	0000	PIO bus check (inbound parity)
	A03	0001	PIO bus check (adapter not detected)
	A04	0010	PIO time out (outbound address parity check)
	A05	0011	PIO time out (outbound cmd/data parity check)
PCA2	A06	0D80	Adapter down
	A07	0800	PIO bus check (inbound parity)
	A08	0801	PIO bus check (adapter not detected)
	A09	0810	PIO time out (outbound address parity check)
	A0A	0811	PIO time out (outbound cmd/data parity check)
PCA3	A0B	1580	Adapter down
	A0C	1000	PIO bus check (inbound parity)
	A0D	1001	PIO bus check (adapter not detected)
	A0E	1010	PIO time out (outbound address parity check)
	A0F	1011	PIO time out (outbound cmd/data parity check)

<i>Table 11-11 (Page 2 of 4). MOSS BER Type 01 ID 00 Error Codes Description</i>			
Field Name	Hexa Code	MOSS Check Code (Hexa)	Description
MCCU-A	A10	1D80	Adapter down
	A11	1D81	Adapter down (too many spurious error)
	A12	1C60	Adapter check (bus counter parity)
	A13	1C61	Adapter check (MIOC/CCU time out parity)
	A14	1A00	CHIO bus check
	A15	1A10	CHIO time out
	A16	1A20	CHIO storage ECC (RS data parity during MS)
	A17	1A21	CHIO storage ECC (multiple bits in DIV)
	A18	1A22	CHIO storage ECC (no bit in DIV)
	A19	1A30	CHIO exception address (MS data access)
	A1A	1A31	CHIO exception oper (CHCV invalid)
	A1B	1A32	CHIO exception register (CHP 0-7 not zero)
	A1C	1A33	CHIO exception spec (inv addr MS data access)
	A1D	1A34	CHIO exception (multiple bits in DIV)
	A1E	1A35	CHIO exception (no bit in DIV)
	A1F	1A50	CHIO internal check (cache parity)
	A20	1A51	CHIO internal check (inv addr on CHP access)
	A21	1A52	CHIO internal check (multiple bits in DIV)
	A22	1A60	CHIO adapter check (step counter parity)
	A23	1A61	CHIO adapter check (hw/burst counter parity)
	A24	1A62	CHIO adapter check (CCU busy time out)
	A25	1A63	CHIO adapter check (MIOC time out)
	A26	1A64	CHIO adapter check (MIOC parity check in)
	A27	1A65	CHIO adapter check (MIOC parity check out)
	A28	1A66	CHIO adapter check (adapter failure)
	A29	1A67	CHIO adapter check (multiple bits in STAT register)
	A2A	1A68	CHIO adapter check (no CHIO in progress in ACB)
	A2B	1AA0	CHIO (multiple bits in EIRV)
	A2C	1AA1	CHIO (no CHIO in progress in ACB)
	A2D	1960	Dev adapter check (step counter parity)
	A2E	1961	Dev adapter check (MIOC time out)
	A2F	1962	Dev adapter check (MIOC parity check in)
	A30	1963	Dev adapter check (MIOC parity check out)
	A31	1964	Dev adapter check (adapter failure)
	A32	1965	Dev adapter check (multiple bits in STAT register)
	A33	1966	Dev adapter check (no CAC running)
A34	1800	PIO bus check (inbound parity)	
A35	1801	PIO bus check (adapter failure)	
A36	1802	PIO bus check (adapter not detected)	
A37	1810	PIO time out (invalid command)	
A38	1811	PIO time out (outbound parity check)	
A39	1812	PIO time out (adapter not detected)	
A3A	1813	PIO time out (adapter failure)	
A3B	1814	PIO time out (multiple bits in STAT register)	
MCAD	A84	3580	Adapter down
	A85	3000	PIO bus check (inbound parity)
	A86	3001	PIO bus check (adapter failure)
	A87	3002	PIO bus check (adapter not detected)
	A88	3010	PIO time out (invalid command)
	A89	3011	PIO time out (outbound parity check)
	A8A	3012	PIO time out (adapter not detected)
	A8B	3013	PIO time out (adapter failure)
A8C	3013	PIO time out (multiple bits in STAT register)	

<i>Table 11-11 (Page 3 of 4). MOSS BER Type 01 ID 00 Error Codes Description</i>			
Field Name	Hexa Code	MOSS Check Code (Hexa)	Description
DFA	A8D	3D80	Adapter down
	A8E	3A00	CHIO bus check
	A8F	3A10	CHIO time out
	A90	3A20	CHIO storage ECC (RS data parity during MS)
	A91	3A21	CHIO storage ECC (multiple bits in DIV)
	A92	3A22	CHIO storage ECC (no bit in DIV)
	A93	3A30	CHIO exception (oper CHCV invalid)
	A94	3A31	CHIO exception (register CHP 0-7 not zero)
	A95	3A32	CHIO exception (spec inv addr MS data access)
	A96	3A33	CHIO exception (address MS data access)
	A97	3A34	CHIO exception (multiple bits in DIV)
	A98	3A35	CHIO exception (no bit in DIV)
	A99	3A50	CHIO internal check (cache parity)
	A9A	3A51	CHIO internal check (inv addr on CHP access)
	A9B	3A52	CHIO internal check (multiple bits in DIV)
	A9C	3AA0	CHIO multiple bits in EIRV
	A9D	3AA1	CHIO no CHIO in progress in ACB
	A9E	3800	PIO bus check (inbound parity)
	A9F	3801	PIO bus check (adapter failure)
	AA0	3802	PIO bus check (adapter not detected)
AA1	3810	PIO time out (invalid command)	
AA2	3811	PIO time out (outbound address parity check)	
AA3	3812	PIO time out (outbound cmd/data parity check)	
AA4	3813	PIO time out (adapter failure)	
AA5	3814	PIO time out (multiple bits in STAT register)	
TOD	AA6	4580	Adapter down
	AA7	4000	PIO bus check (inbound parity)
	AA8	4001	PIO bus check (adapter not detected)
	AA9	4010	PIO time out (outbound address parity check)
	AAA	4011	PIO time out (outbound cmd/data parity check)
PCC	AAB	4B80	Adapter down
	AAC	4B00	MMIO write error
	AAD	4B10	MMIO time out
	AAE	4B30	MMIO exception (address)
	AAF	4B20	MMIO read error
	AB0	4BA0	MMIO not authorized on this level
UC bus	AB1	5580	Adapter down
Register storage	AB2	5820	PIO storage ECC (MPC data parity)
	AB3	5821	PIO storage ECC (MSC data parity)
	AB4	5822	PIO storage ECC (unresolved)
	AB5	5C20	Storage ECC (during PSV swap)
Storage	AB6	6220	CHIO storage ECC (data parity)
	AB7	6520	Storage ECC (data parity)
	AB8	6521	Storage ECC (I-fetch parity)
Loop	AB9	6DA0	Detected
MOSS code	ABA	7590	Pgm error (IO address not authorized)
Diag	ABB	7C90	Pgm error (POR/start unresolved)

Table 11-11 (Page 4 of 4). MOSS BER Type 01 ID 00 Error Codes Description

Field Name	Hexa Code	MOSS Check Code (Hexa)	Description
Level0	ABC ABD ABE ABF AC0 AC1 AC2 AC3 AC4 AC5 AC6	8590 8591 8592 8593 8594 8595 8596 8597 8598 8599 859A	Pgm error (WHO invalid in CPRET) Pgm error (WHO invalid in PPRET) Pgm error (WHO invalid in XPRET) Pgm error (program state unexpected) Pgm error (invalid adapter ID in CHGH0BUS) Pgm error (RAM processor state unexpected) Pgm error (ROS processor state unexpected) Pgm error (CALL stack full) Pgm error (RET stack empty) Pgm error (error code not in BER table) Pgm error (MOSS IMLed routine before IML)
Unexpected	AC7 AC8 AC9 ACA ACB ACC ACD ACE ACF AD0 AD1 AD2	8A40 8DA0 8D60 8800 8801 8802 8803 8810 8811 8812 8813 8C70	CHIO Interrupt level 0 IOIRV interrupt level 0 PIO bus check (no last level) PIO bus check (not IO instruction) PIO bus check (on level 2) PIO bus check (unexpected on level 6) PIO time out (no last level) PIO time out (not IO instruction) PIO time out (on level 2) PIO time out (unexpected on level 6) PIRV program request
Unresolved	AD3 AD4 AD5 AD6 AD7 AD8 AD9 ADA ADB ADC ADD ADE ADF AE0 AE1 AE2 AE3 AE4 AE5 AE6 AE7	9530 9531 9532 9533 9534 9535 9536 9537 9538 9539 953A 953B 953C 9550 9551 9552 9553 9554 9520 9521 9522	Exception address (I fetch) Exception address (MS data access) Exception fixed point overflow Exception (inv addr on non MS access) Exception (multiple bits in DIV) Exception (multiple bits in EIRV) Exception oper (invalid opcode) Exception register (precision) Exception spec (inv addr on I fetch) Exception spec (inv addr on MS data access) Exception spec (inv addr on non GPR access) Exception spec (inv execution of ki) Exception spec (PSV bits 40-44-47 not zero) Internal check (cache register parity check) Internal check (inv address on GPR access) Internal check (inv address on PSV swap) Internal check (multiple bits in DIV) Internal check (multiple bits in EIRV) Storage ECC (multiple bits in DIV) Storage ECC (multiple bits in EIRV) Storage ECC (no bit in DIV)
MLA	AE8 AE9 AEA AEB	9B80 9B30 9B20 9BA0	Adapter down MMIO exception MMIO read error MMIO not authorized on this level
Specific	Cxx Dxx	76xx 3Cxx	PIRV (abend request) Disk adapter return code

BER Type 01 ID 00 - Fields Details

Some of the following fields may not appear on the ELD detail display, but they are part of the BER and they are listed as they appear in the BER file. See the section 'BER Formats on Disk' page 11-112

<i>Table 11-12 (Page 1 of 6). BER Type 01 ID 00 Field Details</i>		
Field Name	Bit Pattern	Description
DIV (byte 1)		Diagnostic information
	00 1 1 0000	Sector must be zero Error occurred during main store operation. Error occurred during a register backing store operation DMA identification must be zero
DIV (byte 2)		Sector specification
	1 1 1 1 1 1 1 1 1	Exception memory subsystem detected an invalid address Error occurred during a PSV swap operation Operation exception: attempt to execute an invalid instruction A register precision occurred (result > 24 bits) Address exception: address > X'7FFFFFF' or wrapped to zero Error occurred during an instruction fetch Fixed point overflow External error loaded in EIRV/DIV
EIRV		Error interrupt request vector
	1 1 1 1 1 1 1 1 0	I/O control check Time out check Storage data/ECC check Exception (addr,op,spec.) Channel I/O check Internal control check Instruction address modifier (IA points to the beginning of the instruction) Unused (must be zero)
IOIRV		I/O interrupt request vector
	1 1 0 1 1 1 1 00	MCC adapter check MCC high level interrupt or 100 ms timer interrupt Power control interrupt request MCA interrupt request MCC low level interrupt DFA interrupt request Unused (must be zero)
PIRV		Programmed interrupt request vector
	1 1 1 1 1 1 1 1	MOSS error level 0 handler MOSS error level 0 process Power control interrupt request MOSS MCA level 3 handler MOSS MAC level 4 handler MOSS DFA level 5 handler MOSS Supervisor level 6 and task scheduler MOSS tasks level 7 programs

<i>Table 11-12 (Page 2 of 6). BER Type 01 ID 00 Field Details</i>		
Field Name	Bit Pattern	Description
CPLLPL		Current/last priority level
	0 xxx 0 xxx	Unused (must be zero) Current priority level (000 to 111) Unused (must be zero) Last priority level (000 to 111)
CM		Common mask interrupt vector
	1 1 1 1 1 1 1 1	Level 0 enabled Level 1 enabled Level 2 enabled Level 3 enabled Level 4 enabled Level 5 enabled Level 6 enabled Level 7 enabled
MM		Master mask interrupt vector
	0000 000 1	Unused (must be zero) Enabled
CHM		Channel mask interrupt vector
	0000 000. 1	Unused (must be zero) Enabled
CHCV		Channel control vector
CHCV (byte 2)	0000 0 x x x x x x x x x x x	Unused (must be zero) Channel pointer number 0 = CPR within set 12-15 1 = CPR within set 8-11 Indirect operation 0 = Mode determined by bit 1.1 1 = Indirect mode 0 = Short address 1 = Long address 0 = Write 1 = Read 0 = Indirect mode (Must be 0 if bit 0.6 is 1) 1 = Direct mode CHCV pointer number 0 = CHCV (0-6) used 1 = CHCV (0-6) not used
IA		Interrupted address
byte 1 bytes 2-4	0000 0000	Unused (must be zero) Address
PSCI		Program status code indicator register space
byte 1 byte 2 byte 3 byte 4	0000 0000 0000 0 . . 0 1 . 1 1 1 1 xx xxxx 1 1	Unused (must be zero) Unused (must be zero) Restricted address branch mode (64 K domain only) Master mode PIO and reg indirect Z indicator H indicator Secondary set number C indicator V indicator

<i>Table 11-12 (Page 3 of 6). BER Type 01 ID 00 Field Details</i>		
Field Name	Bit Pattern	Description
	. . xx xxxx	Primary set number
LOPC 1		Last operation code address
bytes 1-2 bytes 3-4	hh hh hh hh	1st part of the address 2nd part of the address
REGS		Registers of interrupted level
28-51 Prim. set 52-75 Sec. set	xxxxxx xxxxxx xxxxxx xxxxxx	
Dump		MOSS dump/IML info
IML informa- tion (IML request)	1 1 1 1 1 1 1 1 1 1 1 1 1 1 1	Dump requested Re-IML requested Unused (must be zero) Re-IML count
DUMP status		MOSS dump file status
	0000 0000 1	File free Enabled
MCCU A		MCCU A status register 0
byte 1 byte 2	1 1 1 1 1 1 1 1 1 1 1 1 1 1 1	MOSS inoperative Step/bus counter parity MIOC/CCU counter parity HW/burst counter parity CCU busy time out MIOC time out MIOC parity check in MIOC parity check out Invalid PIO Cmd UC bus parity check Unused MIOC busy CHIO halt Equipment check Enable interrupt level 0 Interrupt level 0 (read only)
MCCU A		MCCU A status register 1
byte 3 byte 4	xxxx x 1 xx xxxx x 1 1 1 1	Unused Enable CCU HLIR Unused Unused CCU HLIR Enable all interrupts Interrupt level 1
MCCU A		MCCU A status register 4
byte 5 byte 6	xxx 1 1 1 xx 1 xx 1 1 1 x 1	Unused Enable cycle steal end Enable CCU LLIR Enable CSP IOC1 interrupt Unused Programm wait Unused Cycle steal end CCU LLIR CSP IOC1 interrupt Unused Interrupt level 4
MCCU A		MCCU A MMOD register

<i>Table 11-12 (Page 4 of 6). BER Type 01 ID 00 Field Details</i>		
Field Name	Bit Pattern	Description
byte 7	x 1 1 1 1 1 1 1	Unused Step 0 Step 1 Freeze MIOC direct oper mode MIOC write mode (CHIO) MIOC read mode (CHIO) DREG full
byte 8	x 1 1 1 1 1 1 1	Reserved for diagnostics Parity prediction diag 1 Parity prediction diag 0 MIOC diag 2 MIOC diag 1 MIOC diag 0 MOSS diag 2 MOSS diag 1 MOSS diag 0
byte 9	xxxx xxxx	MCCU A count register
byte 10	xxxx xxxx	MCCU A count register
byte 11	xxxx xxxx	CHCV register
byte 12	xxxx xxxx	CHCV register
MCAD (byte 1)		MCAD INTP1 register
	1 1 xx x 1 1 1	Invalid PIO command UC bus parity check Unused Equipment check Enable interrupt level 1 Interrupt level 1
MCAD (byte 2)		MCAD EINTP1 register
	1 1 xx 1 1 xx	Enable timer Enable CADS 5-8 HLIR Unused 100 ms timer CADS 5-8 HLIR Unused
MCAD (byte 3)		MCAD INTP4 register
	1 1 xx 1 1 x 1	Enable fault flags Enable CADS 5-8 LLIR Unused Fault flags CADS 5-8 LLIR Unused Interrupt level 4
MCAD (byte 4)		MCAD sense fault flags
	xx 1 1 xxxx	Unused Fault ENA/REST 5-6 Fault ENA/REST 7-8 Unused
MCAD (byte 5)		MCAD diagnostics register
	1 xxx xxxx	All CAs disabled Unused Force error
MCAD (byte 6)		MCAD sense CA enable
	xxxx	Unused

Table 11-12 (Page 5 of 6). BER Type 01 ID 00 Field Details		
Field Name	Bit Pattern	Description
 1111	CA 5 enabled CA 6 enabled CA 7 enabled CA 8 enabled
MCAD (byte 7)		Unused
MCAD (byte 8)		MCAD CAMPOR register
	xxxx 1x11	Unused CADS 5-8 nohold (reset by 'reset adapter' cmd) Unused CADS 5-8 MOSS POR (reset by 'reset adapter' cmd) Unused
MCAD		MCAD ENCA register
bytes 9-10	xxxx xxxx xxxx xxxx	Each bit enables a CA from 5 to 8
MCAD		MCAD CARST register
bytes 11-12	xxxx xxxx xxxx xxxx	Each bit resets a CA from 5 to 8
PCA1, PCA2, or PCA3		PCA1, PCA2, or PCA3 basic status register
byte 1	1111 1111	Input request Output request DCE interrupt Timer interrupt Exception Equipment check Enable
byte 2	1111 1111	Interrupt request PCA 1, 2, or 3 A status register Overrun Underrun Receive clock running SDLC invalid sequence SDLC flag
byte 3	111x xxx1	Invalid character Break byte detected Adapter in sync PCA A control register Receive mode Transmit mode Inhibit zero insert Mode select Code length NRZI/break
byte 4	1111 1011	PCA M status register Data set ready Clear to send Receive line signal det Ring indicator Data set ready transit Unused (must be zero) RLSD transition Clear to send transition
byte 5	1111 1 ...	PCA M control register Data terminal ready Request to send Wrap Test Select stand by

<i>Table 11-12 (Page 6 of 6). BER Type 01 ID 00 Field Details</i>		
Field Name	Bit Pattern	Description
 1 1 1	Select half-speed New sync DCE interrupt disable
DFA (Byte 1)		DFA basic status register
	xx 1 1 1 1 1 1	Attachment status: <ul style="list-style-type: none"> • 0 0 = idle • 0 1 = busy attention loaded • 1 0 = busy reset • 1 1 = busy CHIO UC bus parity check Invalid PIO command CHIO halt Equipment check Enable Interrupt request
DFA (byte 2)		DFA attention register
	1 1 1 1 1 1 1 0 0	Command control block Command specification Sense summary block Data request bit Drive select high bit Drive select low bit Unused (must be zero)
DFA (byte 3)		DFA interrupt status register
	1 1 1 1 1 1 1 1	Termination error Invalid command Command reject Parity error Drive select high bit Drive select low bit ERP invoked Equipment check
TOD		TOD status register
	0000 0 1 1 1	Unused (must be zero) Equipment check Enable Interrupt request
SNAP		Snapshot dump (abend)
byte 1 bytes 2-27	000x xxxx xxxx xxxx	Length of snapshot Dump
MLA byte 1-2 MLA byte 3	0000 0001 0000 0010 0000 0011	Status flag used by the retry process Retry OK No retryable. Force reopen line connection Hardware failure MLA register
MLA byte 4	100x xxxx 010x xxxx 001x xxxx	Unimplemented storage violation Read only violation Parity error
MLA bytes 5-6		Previous MOSS check

MOSS BER Type 01 ID 01

Format foM1: see page 11-112. MOSS microcode level 1 generates the following BER:

```

                                ELD DETAIL
SEL#:hhhh FLAG:hh DATE:dd/dd TIME:dd:dd TYPE:01 ID:01
LVL1 < error description line > <REFER.CODE IN CHAR.> CCCCCC
WHO-WHAT:bbbbbbb -CHECK:hh -ABEND:hh
MCCUA REGS:hhhh hhhh hhhh hhhh hhhh hhhh CMSA:bbbbbbb
X75:hhhhh X76:hhhhh LSR:hhhhh CP-ABEND:hhhh TA:hhhh STATUS:bbbbbbb

MCCUB REGS:hhhh hhhh hhhh hhhh hhhh hhhh CMSA:bbbbbbb
X75:hhhhh X76:hhhhh LSR:hhhhh CP-ABEND:hhhh TA:hhhh STATUS:bbbbbbb

MCAD REGS:hh hh hh hh hh hhhh hh hhhh hhhh
CCU:hh IOC:hh NUM:hh

====>

F1:END F2:MENU2 F3:ALARM F4:SUMMARY F5:LIST F7:PREVIOUS F8:NEXT
    
```

Note: All values except the fields 'WHO' and 'WHAT' are in hexadecimal notation (X'0' to X'F').

MOSS BER Type 01 ID 01 - Field Description

Table 11-13. MOSS BER Type 01 ID 01 Field Description		
Field Name	Meaning	Refer to
WHO	In binary (first part of error explanation)	Page 11-51
WHAT	In binary (second part of error explanation)	Page 11-51
ABEND	Level 1 abend codes: . 4E = Permanent HLIR . 4F = Too many spurious errors . FF = No abend code	
CMSA	CCU to MOSS status register A (X'11')	
CHECK	Error	Page 11-51
STATUS	Level 1 status	Page 11-51
X75	X'75' - AIO CSCW byte X, byte 0, byte 1 (only used with error code 07, program request IPL)	Page 2-25
X76	X'76' - IOC level 1 interrupt request (only used with error code 07, program request IPL)	Page 2-25
TA	TA register	
LSR	Local store register	Page 2-21
MCCUA	MOSS to CCU A registers	Page 11-46
MCCUB	Not used (all fields not significant)	-
MCAD	MOSS to CA registers	Page 11-47
CCU	CCU selected for CA	
	<ul style="list-style-type: none"> • hh = 01: CCUA • hh = 02: CCUB 	
IOC	IOC selected for CA	
	<ul style="list-style-type: none"> • hh = 01: IOC1 • hh = 02: IOC2 	
NUM	CA number	

MOSS BER Type 01 ID 01 - Field Details

Some of the following fields may not appear on the ELD detail display, but they are part of the BER and they are listed as they appear in the BER file. See the section 'BER Formats on Disk' page 11-112

<i>Table 11-14. MOSS BER Type 01 ID 01 Field Details</i>		
Field Name	Bit pattern or Hex value	Meaning
WHO	0000 0001 0010 0011 0100 0101 0110 0111 1000 1001	Gives the origin of the error Unresolved CCU A Unused CADS1 CADS2 Timer MCAD Unused CCU A power OFF Unused
WHAT	0000 0001 0010 0011 0100 0101 0110 0111 1000 1001 1010 1011 1100 1101 1110 1111	Gives the type of error Unused Under diags CCU hardcheck Program IPL request Host IPL request Multiple IPL request I/O error alert CCU stop IOC operation error Address exception Operation check CADS MIOH error Timer interrupt Unresolved CCU power OFF ESCA IPL request
Check	00 01 02 03 04 05 06 07 08 09 0A 0B 0C 0D 0E 0F 10 11	No error on level 1 MOSS OK Adapter OK No error during CHIO Unable to reset HLIR CCU not IPLed IPL already in progress Unable to read CCU information Unable to read adapter registers Unable to read CCU registers Multiple bit in CMSA No bit in CMSA CAC not running Unexpected interrupt Unresolved interrupt No interrupt in AMAC card No interrupt in IOIRV No action for MOSS level 1
Status	20 40 80	CCUA X'76' CCUA CMSA MCCUA status Register 1

Note: For the list of suspected FRUs, refer to the MIP.

MOSS BER Type 01 ID 02

Format foM2: see page 11-113. The MOSS microcode generates the following BERs when an error occurs during CCU/MOSS exchanges.

```

                                ELD DETAIL
SEL#:hhhh  FLAG:hh  DATE:dd/dd  TIME:dd:dd  TYPE:01  ID:02
MIOC < error description line >          <REFER.CODE IN CHAR.> CCCCCCCC
MOSS-CHECK:hh  ADNO:hh  CMD:hh  PIRV:hh  IOIRV:hh  CMSB:hh  STAC:hh
CAC-RC:hh  STAT1:hhhh  STAT4:hhhh  ADDR:hhhhhhhh
PCW:hhhhhhhh  hhhhhhhh  hhhhhhhh  FLAGS:hh  CA:hh

====>

F1:END F2:MENU2 F3:ALARM F4:SUMMARY F5:LIST F7:PREVIOUS F8:NEXT

```

MOSS BER Type 01 ID 02 With MOSS Check 04

Format foM2b: see page 11-113. The MOSS microcode generates the following BER for a MIOC invalid mail box on level 4 process.

```

                                ELD DETAIL
SEL#:hhhh  FLAG:hh  DATE:dd/dd  TIME:dd:dd  TYPE:01  ID:02
MIOC < error description line >          <REFER.CODE IN CHAR.> CCCCCCCC
MOSS-CHECK:04  CMD:hh
NCP MB REQUEST:hhhhhhhh  hhhhhhhh  hhhhhhhh  hhhhhhhh
NCP MB RESPONSE:hhhhhhhh  hhhhhhhh  hhhhhhhh  hhhhhhhh

====>

F1:END F2:MENU2 F3:ALARM F4:SUMMARY F5:LIST F7:PREVIOUS F8:NEXT

```

MOSS BER Type 01 ID 02 - Field Description

Table 11-15. MOSS BER Type 01 ID 02 Field Description		
Field Name	Meaning	Refer to
CMD	Logical command (used in the error description line)	Page 11-54
MOSS-CHECK	Error code (used in the error description line)	Page 11-54
CA	Channel adapter number (1 to 16)	
ADNO	<ul style="list-style-type: none"> CA adapter number, or Adapter CCU number (05 for CCUA). 	
PIRV	Programmed interrupt request vector	Page 11-44
IOIRV	I/O interrupt request vector	Page 11-44
CMSB	CCU to MOSS status register B (X'06')	
CAC-RC	CAC return code or error code	Page 11-54
STAT1	MCC status reg 1	Page 11-46
STAT4	MCC status reg 2	Page 11-46
ADDR	PCW list address.	For PE only
FLAGS	Adapter control block flags	page 11-55
STAC	CCU to MOSS C register	
PCW	Program control word. Command sent by the CCU.	For PE only
NCP MB REQUEST	NCP mailbox request	
NCP MB RESPONSE	NCP mailbox response	

MOSS BER Type 01 ID 02 - Field Details

Some of the following fields may not appear on the ELD detail display, but they are part of the BER and they are listed as they appear in the BER file. See the section 'BER Formats on Disk' page 11-112

<i>Table 11-16 (Page 1 of 2). MOSS BER Type 01 ID 02 Field Details</i>		
Field Name	Bit Pattern or Hex Value	Meaning
CMD	01	Logical command
	02	Read B register error impossible
	04	MIOC request
	08	Interrupt level 4 processing
	20	Display registers
	21	Control program buffer reading
	40	Control program buffer writing
	41	Out mailbox request
	80	Out mailbox response
	81	In mailbox request
	90	In mailbox response CHIO command
MOSS-CHECK	01	Error codes
	02	LSSD string select error
	04	Invalid PCW request
	08	Invalid out-mailbox request
	10	In-mailbox time out response
	20	Unexpected in-mailbox response from CP
	21	Unresolved interrupt
	22	C-clock stop
	40	Invalid interrupt level 4
	41	CCU busy bit ON
	42	Devices busy bit ON
	80	CCU power down
	86	Physical error reported
87	CHIO asynchronous error	
88	CHIO synchronous error CHIO time out	
CAC-RC	00	CAC return code or error code
	01	Return code OK
	02	Adapter down
	03	LSSD string ID error
	04	LSSD residual count
	05	CCU busy bit ON
	06	Device busy bit ON
	07	IOC error
	08	Op check
	09	Exception
	0A	Scanner error 1
	0B	CHIO failed
	0C	Unexpected interrupt
	20	I/O interrupt cannot be reset
	40	CADS to MOSS level 1
	80	Abend request
	81	CCU power down
FF	Invalid PCW Failed	

<i>Table 11-16 (Page 2 of 2). MOSS BER Type 01 ID 02 Field Details</i>		
Field Name	Bit Pattern or Hex Value	Meaning
FLAGS	80	Adapter control block flags
	40	Adapter down
	20	Adapter checkpoint retry
	10	Adapter Xparent retry thresh.
	08	Time out on adapter
	04	Mail box in request
	02	Timer set for mail box in
	01	Moss Off line Cmd in mail box
	81	Moss On line Cmd in mail box
	82	CHIO operation in process
83	Timer set for CHIO ope CHIO retry has been done	

MOSS BER Type 01 ID 03

Format foM3: see page 11-113. The MOSS microcode generates the following BERs when an error occurs in the disk/diskette drive or disk drive adapter.

```

                                ELD DETAIL
SEL#:hhhh  FLAG:hh  DATE:dd/dd  TIME:dd:dd  TYPE:01  ID:03
< error description line >          <REFER.CODE IN CHAR.> CCCCCCCC
MOSS-CHECK:hh  DEV:hh  FILE:hhhhhhh  CMD:hh  REQ:hh
F:hh  CNT:hh  ARC:hh  BSTAT:hhhh  ADDR:hhhhhhh
BCLE:hhhhhhh  hhhhhhhh  SSB:hhhhhhh  hhhhhhhh  hhhhhhhh

====>

F1:END F2:MENU2 F3:ALARM F4:SUMMARY F5:LIST F7:PREVIOUS F8:NEXT
    
```

MOSS BER Type 01 ID 03 - Field Description

<i>Table 11-17. MOSS BER Type 01 ID 03 Field Description</i>		
Field Name	Meaning	Refer to
CMD	Logical command	Page 11-57
MOSS-CHECK	MOSS-CHECK error codes	Page 11-57
DEV	Device in error	Page 11-57
REQ	Function request code (reserved)	Page 11-57
ARC	Adapter return code	Page 11-59
BSTAT	Basic status register	Page 11-61
F	Flag indicator, last BCLE executed (internal to MOSS)	Page 11-57
CMD	Last BCLE command	Page 11-59
CNT	BCLE-related byte count	Page 11-57
ADDR	Last BCLE-related address	
BCLE	Last executed buffer control list element (CAC-related information)	Page 11-57
SSB	Sense summary block adapter status	Page 11-58
FILE	File name or load module (in EBCDIC)	

MOSS BER Type 01 ID 03 - Field Details

Some of the following fields may not appear on the ELD detail display, but they are part of the BER and they are listed as they appear in the BER file. See the section 'BER Formats on Disk' page 11-112

<i>Table 11-18 (Page 1 of 2). MOSS BER Type 01 ID 03 Field Details</i>		
Field Name	Bit Pattern or Hex Value	Meaning
MOSS-CHECK	01 02 03 04	Bad track but no alternate track assigned. Alternate track successful assigned. Alternate track assignment failure. Disk or diskette down
CMD	00 01 02 03 04 05	Logical command Open Write Read Close Load Direct execute
DEV	01 02 03 04 05 06 07	Adapter failure for disk operations Adapter failure for diskette operations Disk drive Diskette drive Adapter or disk drive Adapter or diskette drive Diskette media (floppy disk)
REQ	00 05 07 25 83 A3 AB EB	Function request code Execute Read operational statistics No-op Read SCA state Open adapter Open SCA Close SCA Terminate (adapter)
F (flag)	1 1	CAC error record Error code indicator Last record indicator
BCLE byte 0	hh	Flag: hh = 00: No command chaining hh = 01: Command chaining
BCLE byte 1	hh	Command field
BCLE bytes 2-3	hh	Count field
BCLE bytes 4-7	hh	Data address

<i>Table 11-18 (Page 2 of 2). MOSS BER Type 01 ID 03 Field Details</i>		
Field Name	Bit Pattern or Hex Value	Meaning
SSB byte 0	1 1 1 1 1 x x 1	Drive status Drive ready Seek end (HDD only) Write protected (FDD only) Write fault (HDD only) Disk change Unused Track 0
SSB byte 1	x 1 1 1 1 1 1 1	SSB error status byte 0 CRC/ECC error x = 0: Data x = 1: ID CRC/ECC error Address mark not found Bad track Wrong cylinder Control address mark Format error ID not found
SSB byte 2	x 1 1 1 xxxx	SSB error status byte 1 Unused Data adapter error Retry corrected Defective sector Unused
SSB bytes 3-6		Last data adapter ID field processed
SSB bytes 7-8		Cylinder and head location
SSB byte 9		Number of sectors corrected by ECC
SSB byte 10		Number of retries
SSB byte 11		Processor state at reset time

Notes:

1. All values are in hexadecimal notation (X'0' to X'F'), except for the file name or module name (FILE), which is in EBCDIC.
2. The CAC will make several retries (up to 10). The retry count contains the number of retries before the disk operation was successfully terminated.
 - If RCNT is lower than 10, the last I/O operation was successful. The error was intermittent.
 - If RCNT = 10, the decision (recovery or program action) is taken by the MOSS application that activated the diskette operation. The error is permanent (solid).

Adapter Return Codes (ARC)

The error description line is built from the contents of the ARC.

<i>Table 11-19. MOSS BER Type 01 ID 03 Adapter Return Codes</i>		
Field Name	Hex Value	Meaning
ARC		EXCEPTION/SUCCESS CLASS
	22 23 30 31	SCA ready (exception) SCA not ready (exception) SCA not ready (no error) Control record found
ARC		ERROR / NOT SUCCESSFUL CLASS
		SEQUENCE ERRORS
	01 02 05 06 08 09 0A 0D 0E	Adapter busy-attention FRB busy. Adapter busy-CHIO Adapter busy-reset SCA 1 not open SCA 2 not open Adapter not open SCA 1 already open SCA 2 already open
		PARAMETER PROBLEMS
	11 12 13	FRB program check BCL program check Invalid PIO command
		HARDWARE AND EQUIPMENT CHECKS
	20 28	Undetermined equipment check (hardware error in adapter) Seek check
		DATA TRANSMISSION PROBLEMS
	30 32 34 37 38 39 3A 3B 3C 3E	Termination error with no specific error Sect buffer parity error Cylinder overrun HALT during a CHIO operation I/O bus parity error CCB with no active CSB Invalid command in CCB or SSB ERP invoked by thresher Internal parity error Record not found
		PREEMPTIVE REQUEST CLASS
	0B 0C	Preemptive request complete Preemptive request rejected
		L/OPERATOR INTERVENTION REQUIRED
	62 6F	SCA not ready (error) Invalid diskette format
		I/O MACHINE CHECK
	76 F6	PIO MCK (non-recursive) PIO MCK (recursive)

MOSS BER Type 01 ID 04

Format foM4: see page 11-113. The MOSS microcode generates the following BER when an error occurs on the console or its adapter cards:

```

                                ELD DETAIL
SEL#:hhhh  FLAG:hh  DATE:dd/dd  TIME:dd:dd  TYPE:01  ID:04
DPLY< error description line >  <REFER.CODE IN CHAR.> CCCCCC
MOSS-CHECK:hh  CMD:hh  BSTAT:hh  ASTAT:hh  CSTAT:hhhh  MSTAT:hh

====>

F1:END F2:MENU2 F3:ALARM F4:SUMMARY F5:LIST F7:PREVIOUS F8:NEXT
    
```

MOSS BER Type 01 ID 04 - Field Description

<i>Table 11-20. MOSS BER Type 01 ID 04 Field Description</i>		
Field Name	Meaning	Refer to
ASTAT	Adapter error status register	Page 11-60
BSTAT	CCA card basic status register	Page 11-61
CMD	Logical command	Page 11-61
CSTAT	Console status	Page 11-61
MOSS-CHECK	Error code	Page 11-62
MSTAT	Modem status register	Page 11-62

Note: All values are in hexadecimal notation (X'0' to X'F').

MOSS BER Type 01 ID 04 - Field Details

Some of the following fields may not appear on the ELD detail display, but they are part of the BER and they are listed as they appear in the BER file. See the section 'BER Formats on Disk' page 11-112

<i>Table 11-21 (Page 1 of 3). MOSS BER Type 01 ID 04 Field Details</i>		
Field Name	Bit Number or Hex Value	Meaning
ASTAT		MOSS-CHECK = X'0A' Adapter exception status
	x	Read/open halted
	. x	XMIT/RCV contention occurred
	. . x	BREAK character received
	. . . x xxxx	Unused

<i>Table 11-21 (Page 2 of 3). MOSS BER Type 01 ID 04 Field Details</i>		
Field Name	Bit Number or Hex Value	Meaning
ASTAT	x x x x x x x x x	MOSS-CHECK = X'0C' or '8C' Parity error on receive data DCE error RCV line at space RCV data buffer too short (overflow) Unused Machine check error RCV text time out Lost data (overrun)
ASTAT	x x x x x x x x x	MOSS-CHECK = X'8A' Adapter exception status Parity error on received data DCE error RCV line at space RCV data line too short Unused Machine check error RCV text time out Data lost (overrun)
BSTAT	01 02 04 08 10 20 40 80	CCA basic status register bit assignment Adapter interrupt pending Adapter enabled MCPC interrupt Exception interrupt Timer interrupt Modem interrupt CSR - output request CSR - input request
CMD	08 10 20 40 80 81	Logical commands Lock keyboard Close adapter Read/write adapter Write adapter Open CCA adapter Open console
CSTAT	Bits 0-0 0-1 0-2 0-3 0-4 0-5 0-6 0-7 1-0 1-1 1-2 1-3 1-4 1-5 1-6 1-7	Console status ERROR: X'40','C0' Parity bit Not bit 2 Communication buffer overrun Line parity error detected Command error detected Unused Keyboard locked Unused Parity bit Not bit 2 Block mode Half-duplex mode Unused Unused Program mode Unused

Table 11-21 (Page 3 of 3). MOSS BER Type 01 ID 04 Field Details

Field Name	Bit Number or Hex Value	Meaning
MOSS-CHECK codes	0A	CAC detected exception (local) ASTAT = adapter exception
	0C	CAC detected error (local) ASTAT = adapter error
	40	Console error (local)
	40	Console error (remote)
	8A	CAC detected exception ASTAT = adapter exception status (remote)
	8C	CAC detected error (remote) ASTAT = adapter error
MSTAT		CCA modem status register bit assignment
	01	CTS transition
	02	RLSD transitions
	04	Reserved
	08	DSR transition
	10	Ring indicator
	20	Received line signal detector (RLSD)
	40	Clear to send (CTS)
80	Data set ready (DSR)	

Note: The correct console status is X'4030'.

MOSS BER Type 01 ID 05

Format foM5: see page 11-113. The MOSS microcode generates the following BERs when an error occurs on a scanner or on the MOSS/scanner connections.

```

                                ELD DETAIL
    < error description line >          <REFER.CODE IN CHAR.> CCCCCCCC
    SEL#:hhhh  FLAG:xx  DATE:dd/dd  TIME:dd:dd  TYPE:01  ID:05
    < Error description line>
    <MOSS-CHECK:xx ADDR:hh>=Unexpected interrupt received
    <MOSS-CHECK:xx ADDR:hh CSCHK:hhhh>
    <MOSS-CHECK:xx ADDR:hh MBST:hhhh>
    <MOSS-CHECK:xx ADDR:hh TD:hhhh>
    <MOSS-CHECK:xx ADDR:hh DUMP:hh hh
      hhhh hhhh hhhh hhhhhhhh hhhh
      hhhh hhhh hhhh hhhhhhhh hhhh>

    ==>

    F1:END F2:MENU2 F3:ALARM F4:SUMMARY F5:LIST F7:PREVIOUS F8:NEXT
  
```

Table 11-22. MOSS BER Type 01 ID 05 MOSS-CHECK Details

MOSS Check	Meaning
01	Scanner failure during IPL
02	Mailbox contains the error status
04	Unexpected interrupt received
05	Scanner is inoperative
09	Scanner checkout failure
0A	Scanner mailbox error status
0B	Scanner time out
18	Scanner IML complete
F0	Scanner dump and IML
F1	Scanner IML and dump full
F2	Scanner IML and disk error on dump
F3	Scanner IML and MAC error on dump
F4	Scanner dump or reinitialization failure
F5	Scanner dump and IML/CP time out on connection
F6	Scanner dump and IML/MAC error connection
F7	Scanner dump and IML/connection mailbox reject
F8	Scanner IML failure and dump full
F9	Scanner IML failure and disk error on dump
FA	Scanner IML failure and MAC error on dump
FB	Scanner down
FC	Scanner down

MOSS BER Type 01 ID 05: Format foM5, see page 11-113. The MOSS micro-code generates the following BER when an error occurs on MOSS or during IOH operations.

```

                                ELD DETAIL
    < error description line >      <REFER.CODE IN CHAR.> CCCCCCCC
SEL#:hhhh  FLAG:xx  DATE:dd/dd TIME:dd:dd  TYPE:01  ID:05
<MOSS-CHECK:hh ADDR:hh X76:hhhhhh STATUS:hhhh>

====>

    F1:END F2:MENU2 F3:ALARM F4:SUMMARY F5:LIST F7:PREVIOUS F8:NEXT
    
```

Table 11-23. MOSS BER Type 01 ID 05 MOSS-CHECK Details

MOSS Check	Detected by LVL	Meaning	Status
08	1	Get error status IOH	Type 1, 2, or 3
10	4	NO information	No status available
20	4	Mailbox status in BER	Command completion
40	4	Get error status IOH	Type 1, 2, or 3
80	1		No status available

MOSS BER Type 01 ID 05: Format foM5a, see page 11-114.

```

                                ELD DETAIL
SEL#:hhhh  FLAG:hh  DATE:dd/dd TIME:dd:dd  TYPE:01  ID:05
< Error description line>      <REFER.CODE IN CHAR.> CCCCCCCC

MOSS-CHECK:F0  ADDR:hh  DUMP:hh hh ← A
hhhh hhhh hhhh hhhhhhhh hhhh
|-----|
|   |   |   |   |   |
| B | C | D | E | F |
|   |   |   |   |   |
|-----|

hhhh hhhh hhhh hhhhhhhh hhhh
|   |   |   |   |   |
| G | H | I | J | K |
|   |   |   |   |   |
|-----|

====>

    F1:END F2:MENU2 F3:ALARM F4:SUMMARY F5:LIST F7:PREVIOUS F8:NEXT
    
```

The field indicated by the letter **A** contains:

- The **DUMP error code** in the first byte
- The **IML error code** in the second byte, as follows:

<i>Table 11-24. 'A' Field Details</i>		
Field Name	Value	Meaning
Dump error code	00	Dump available
	01	Dump not taken (dump file already full)
	02	Dump not available (diskette error)
	03	Dump not available (hardware error MIOC/TSS)
	FF	Dump not taken
IML error code	01	Re-IML not successful
	02	Connect not successful, CP not answering (re-IML OK)
	03	Connect not successful (MIOC operation failed)
	04	Connect not successful, rejected by CP
	05	Threshold (no dump and no re-IML)
	10	Re-IML successful
	FF	Re-IML successful

Note: All other combinations of byte values for the DUMP field are not valid. The other fields indicated by the letters **B** to **K** have the following meaning:

<i>Table 11-25. 'B' to 'K' Field Details</i>	
Field ID	Meaning
B	Last in TA for dump
C	Last out TA for dump
D	Last TD for dump
E	Last MB for dump. This field contains the first four bytes
F	Last disk ECB for dump
G	Last in TA for re-IML
H	Last out TA for re-IML
I	Last TD for re-IML
J	Last MB for re-IML. This field contains the first four bytes
K	Last disk ECB for re-IML

Note: Invalid fields contain all 'F's.

MOSS BER Type 01 ID 05 - Field Description

<i>Table 11-26. MOSS BER Type 01 ID 05 Field Description</i>		
Field Name	Meaning	Refer to
ADDR X76	Scanner address as shown in "Scanner Addressing" (Hex) X'76' (bytes X, 0, and 1 of field X76 on screen) or MOSS command completion (bytes 0 and 1; X not used)	MIP chapter 5 Page 2-25
STATUS TD	Error status, or mailbox status, depending on the error code Last command (DB0 and DB1 at TD time)	Page 11-64 Chapter 8
MBST	Mailbox status	Chapter 8
CSCHK	Scanner status	--
ADAPTER ID	IOC bus ID	--

Notes:

1. All values are in hexadecimal notation (X'0' to X'F').
2. For details of scanner/MOSS communication, see Chapter 8.

MOSS BER Type 01 ID 06 (Error 01 or 02)

BER format foM7: see page 11-114. The MOSS microcode generates the following BER when an error occurs in the BER file outside controller initialization.

The error description line contains information such as the CP abend code, the scanner address, or the number of BERs lost.

```
                                ELD DETAIL
SEL#:hhhh  FLAG:hh  DATE:dd/dd  TIME:dd:dd  TYPE:01  ID:06
APPL< error description line >          <REFER.CODE IN CHAR.> CCCCCC
MOSS-CHECK:hh

===>

F1:END F2:MENU2 F3:ALARM F4:SUMMARY F5:LIST F7:PREVIOUS F8:NEXT
```

Note: For software information on BERs originated by NCP/PEP, refer to the associated product documentation.

MOSS BER Type 01 ID 06 (Error 03 or 06)

This BER corresponds to one of the following cases:

- IPL check
- IPL complete + errors

For 'IPL complete with errors' the BER is always 'normal' (in opposition to 'composite BERs').

For 'IPL check', the BER logged is a 'composite BER' for physical errors and a normal one for logical errors.

MOSS BER Type 01 ID 06 - Field Details

Some of the following fields may not appear on the ELD detail display, but they are part of the BER and they are listed as they appear in the BER file. See the section 'BER Formats on Disk' page 11-112

According to the error type, the MIS field contents differs:

Error 03 MIS is made from the fields DISK, DISK2, IPL mode and IPLCHECK of the following table.

Error 06 As described in the field MIS (11-71) of the following table.

<i>Table 11-27 (Page 1 of 5). MOSS BER Type 01 ID 06 Field Details</i>		
Field Name	Bit Pattern or Hex Value	Meaning
MOSS-CHECK	03 05 06 08 Ext 05 08 Ext 07 09 13 14 18 28	MOSS error code Complete with errors NCP re-IPL succesful after CCU hard check or NCP abend Check CCU hard check NCP abend CLDP abend Timed IPL will occur soon Timed IPL is cancelled LSSD string first part LSSD string second part
IPL info	01	IPL
CCU	01	Always set to 01
REQ	01 02 03 04 05 06 07 08 09 0A 0B	IPL on power-On reset CCU + scanners IPL req from KBD Unused Unused Unused Unused IPL is requested by the level 1 Scheduled or network power-On reset Unused Unused Unused
LVL1-REQ	02 03 04 07	ID of CCU IPL request CCU hardcheck Program request IPL Channel request IPL CCU power drop
STATUS	00 01 10 x x x 10 00 x	System status MOSS only MOSS disconnected System running MOSS has reached the MOSS init part 2, then normal MCPC must be used Unused Scanner not IMLed, alert sent by loop detection task IPL drive: hard disk " " : diskette When ON, no local console available

<i>Table 11-27 (Page 2 of 5). MOSS BER Type 01 ID 06 Field Details</i>		
Field Name	Bit Pattern or Hex Value	Meaning
Abend code	xxxx xxxx xxxx xxxx	IPL abend code
LA byte 1	x x x x x x x x x x	32 blocks (1 per CSP) of 4 bytes, displayed as 8 hexadecimal characters LPTSS found present in CDF TRA found present in the CDF Adapter power ON Scanner/TRA is presently the scanner selected TIC1 found present in CDF TIC2 found present in CDF LA under control of the CP Scanner successfully IMLed
LA byte 2	x x x x x x x x	Automatic re-IML has failed, or scanner went down twice in the minimum time range, or CSP could not be IMLed at general IPL. CMD engaged with scanner failed with a level 1 interrupt on MOSS: interrupt handler failed in trying a get error status register Scanner successfully IMLed, no action (stop, go, connect, disconnect, reset) performed and no scanner error detected: scanner is initialized Unused HPTSS/ESS found present in the CDF
LA byte 3	x1	x identifies the type of LA: 1 TSS 2 HPTSS 3 TRSS 6 ESS The second digit is always set to 01.
LA byte 4	01 02 03 04 05 06 07 08 09 0A 0B 0C 0D 0E 0F to 15	Mismatch between CDF and data returned from the scanner (MUX presence and EXTEND bit) Bad IOC bus test Error during loading of CSP load module Bad CSP checkout result Time out during IOH on CSP Bad block transfer between CCU and CSP Bad CSP initialization Bad return from CHGCDLA access function Bad selective POR Invalid position on power block returned by CDF Scanner responsible of time out at IOC bus test Scanner with the same power source as one with bad UC bus test return Scanner which can not be powered ON Scanner not accessible in CDS Unused
DISK	see DISK bytes 1-2 for details	5 halfwords: <ul style="list-style-type: none"> • 1: OPEN • 2: READ • 3: LOAD • 4: WRITE • 5: CLOSE

<i>Table 11-27 (Page 3 of 5). MOSS BER Type 01 ID 06 Field Details</i>		
Field Name	Bit Pattern or Hex Value	Meaning
DISK byte 1	x x x x x x x x x x	Unused Full instruction test load module IOC bus tests load module CLDP load module Scanner load module Scanner load module member 1 Scanner load module member 2 Scanner load module member 3
DISK byte 2	x x x x x x x x x x	HPTSS/ESS load module HPTSS/ESS load module member 1 HPTSS/ESS load module member 2 HPTSS/ESS load module member 3 SALT load module Stand alone utilities Port swap file Unused
DISK2	x x x x x x x x x x	5 bytes, same allocation as 'halfwords' above Roll in/out file LSR file CCU dump file First dump record file Last dump record file Control program load module file Unused
F2 byte 1	x x x x x x x x x	Bad branch trace buffer length Bad check record pool Bad control program interface table level 1 on CA during CA monitoring X71 register is not readable CLDP did a pseudo abend Loading scanner table failed (phase 3) Control info length error: MB error
F2 byte 2	x x x x x x x x x x x	IPL from disk length error: MB error IPL complete with port swap errors LSSD dump incorrect Adapter dump requested, not performed (bad return from CHGCDDLA access function) Error during save on disk Error during load from disk Error during reset active load mode Error during dump on disk (phase 4) Error during roll-in roll-out of top 64K of storage to/from HDD
X71		X71 register
X72		X72 register
IPL mode	x x xx x xxx	IPL mode (IPLMODE) x = 0 <==> Operator x = 1 <==> Automatic Customer / maintenance (MTMENU) x = 0 <==> Customer x = 1 <==> Maintenance Unused Standalone dump status x = 0 Not requested or failed x = 1 Successfully performed Unused

<i>Table 11-27 (Page 4 of 5). MOSS BER Type 01 ID 06 Field Details</i>		
Field Name	Bit Pattern or Hex Value	Meaning
CCU	01 01 01	Always set to 01
MIS		Miscellaneous. Following byte description is only for error 06 (IPL check). For error 03 MIS is made from the fields DISK, DISK2, IPL mode and IPLCHECK of this table.
Bytes 1		BER error code initialized at IPL
Bytes 2		Unused
Byte 3	x x x x x x x x x x	Valid field indicators IAR is valid SAR is valid LAR is valid IN70 is valid IN76 is valid IN7D is valid IN7E is valid IN7X is valid
Bytes 4-6		IAR
Bytes 7-9		SAR
Bytes 10-12		LAR
Bytes 13-14		INPUT X'70'
Bytes 15-16		INPUT X'76'
Byte 17 x x x x	IN76 IOC1 STATE LATCH (See page 2-35) Time out Bus IN parity AIO PIO
Byte 18		Unused
Bytes 19-20		INPUT X'7D'
Bytes 21-22		INPUT X'7E'
Bytes 23-24		INPUT X'7E' extension
F1	x x x x x x x x x	Disk IPL facility failed PCA of local console not available PCA of remote console not available PCA of RSF console not available MCAD detected KO by MOSS diags Unused MCCUA detected KO by MOSS diags Unused
RC from CDF	xxxx xxxx xxxx xxxx	CDF return code from CDF access function

Table 11-27 (Page 5 of 5). MOSS BER Type 01 ID 06 Field Details		
Field Name	Bit Pattern or Hex Value	Meaning
CADS byte 1	x x x x x x x x	6 bytes per CA (16 CAs) MIOH failure Bad return from CHGCDCA Power OFF Verify data error Bad checkout result Chaining error Mismatch about TPS between CDF and HW Unused
Byte 2	x x x x x x x x	Init error Bad return from MCAD adapter CA not found in 'CONNECTED' status during phase 1B Chaining not performed due to 2 errors on the bus MCAD error when enabling MCAD error when disabling Unused
Bytes 3-4	xxxx xxxx xxxx xxxx	CADS checkout result
Byte 5	0000 0001	CCU (Always set to 01)
Byte 6		Unused
IPLCHECK		Error 03 only (IPL complete with errors)
Byte 1	0000 1111	
Byte 2	x x x x x x x x	Unexpected IPL option Unexpected CCU option Unexpected/undefined F key No CCU under IPL, IPL started No CCU specified for BER Unused Unexpected display request Unused
3746-900	8 h h h 4 h h h 2 h h h 1 h h h	Bad NCP version for the 3746-900 Coupler ready bit No port swap exchange Port swap error for the 3746-900

MOSS BER Type 01 ID 06 (Errors 05/08 Ext 05/07)

BER format foM9: see page 11-115, MOSS-check: 05 EXT: 05/07. The MOSS microcode generates the following BER when a CCU hardcheck occurs. The BER fields contain information fetched from the LSSD strings and saved when the error occurs on CCU hardcheck. Then a re-IPL is started.

```

                                ELD DETAIL
SEL#:hhhh  FLAG:hh  DATE:dd/dd  TIME:dd:dd  TYPE:01  ID:06
APPL< error description line >  <REFER.CODE IN CHAR.> CCCCCCCC
MOSS-CHECK:05  CCU:hh  DUMP:hh

====>

F1:END F2:MENU2 F3:ALARM F4:SUMMARY F5:LIST F7:PREVIOUS F8:NEXT
    
```

BER format foM9a: MOSS-check 08 EXT 05, see page 11-115. The MOSS microcode generates the following BER when a CCU hardcheck occurs. The BER fields contain information fetched from the LSSD strings saved when the error occurs on CCU hardcheck. Then a re-IPL is started.

```

                                ELD DETAIL
SEL#:hhhh  FLAG:hh  DATE:dd/dd  TIME:dd:dd  TYPE:01  ID:06
'3745 RE-IPL STARTED FOR CCU HARDCHECK'.  <REFER.CODE IN CHAR.> CCCCCCCC
MOSS-CHECK:08  EVENT-EXT:05  CCU:hh
IAR:hhhhhh  LAR:hhhhhh  SAR:hhhhhh
X70:hhhhhh  X76:hhhhhh  X7D:hhhhhh  X7E:hhhhhh
HDCK:hhhh

====>

F1:END F2:MENU2 F3:ALARM F4:SUMMARY F5:LIST F7:PREVIOUS F8:NEXT
    
```

MOSS BER Type 01 ID 06 (Errors 05/08 Ext 05/07) - Field Details

Table 11-28. MOSS BER Type 01 ID 06 (Errors 05 or 08) Field Details		
Field Name	Bit Pattern or Hex Value	Meaning
CCU	01	CCU (always set to 01)
NCP abend	xxxx xxxx xxxx xxxx	NCP abend code for alert. See page 11-36
Dump status	01 02	Stand-alone dump status Not requested or failed Successfully performed
HDCK	Byte 1 xxxx xxx x	Unused Unused Level 1 error reentry

MOSS BER Type 01 ID 06 (Error 07)

BER format foM7: see page 11-114.

MOSS BER (ID 06)

```
                                ELD DETAIL
APPL< error description line >    <REFER.CODE IN CHAR.> CCCCCCCC
SEL#:hhhh  DATE:dd/dd TIME:dd:dd  TYPE:01  ID:06
MOSS OFFLINE
MOSS-CHECK:hh

====>

F1:END F2:MENU2 F3:ALARM F4:SUMMARY F5:LIST F7:PREVIOUS F8:NEXT
```

MOSS-CHECK: hh = 07: MOSS is offline.

MOSS BER Type 01 ID 06 (Error 08 Ext 07)

BER format foM19: see page 11-116. The MOSS microcode generates the following BER on CLDP abend and relatedre_IPL request.

```
                                ELD DETAIL
APPL< error description line >    <REFER.CODE IN CHAR.> CCCCCCCC
SEL#:hhhh  FLAG:hh  DATE:dd/dd TIME:dd:dd  TYPE:01  ID:06

MOSS-CHECK:08 EVENT-EXT:07 CCU:hh

====>

F1:END F2:MENU2 F3:ALARM F4:SUMMARY F5:LIST F7:PREVIOUS F8:NEXT
```

MOSS BER Type 01 ID 06 (Error 09)

BER format foM10: see page 11-114. The MOSS microcode generates the following BER when CLDP abends (code X'F1B'). This BER does not follow the 'composite BER' mechanism. The X72 field contains the CLDP abend code

```
                                ELD DETAIL
SEL#:hhh FLAG:hh  DATE:hh/hh TIME:hh:hh  TYPE:01  ID:06
APPL< error description line >    <REFER.CODE IN CHAR.> CCCCCCCC
MOSS-CHECK:09 EVENT-EXT:hh CCU:hh  IAR:hhhhh X71:hhhhh X72:hhhhh
WKR1:hhhhh WKR2:hhhhh WKR3:hhhhh WKR4:hhhhh WKR5:hhhhh WKR6:hhhhh
WKR7:hhhhh
X7E:hhhh  X7D:hhhh  X76:hhhh
CA: XE:hhhh  XD:hhhh  X50:hhhh  X51:hhhh  X52:hhhh  X60:hhhh
LA:hhhhhhh hhhhhhhh hhhhhhhh hhhhhhhh hhhhhhhh hhhhhhhh hhhhhhhh hhhhhhhh
   hhhhhhhh hhhhhhhh hhhhhhhh hhhhhhhh hhhhhhhh hhhhhhhh hhhhhhhh hhhhhhhh

====>

F1:END F2:MENU2 F3:ALARM F4:SUMMARY F5:LIST F7:PREVIOUS F8:NEXT
```

MOSS BER 01 ID 06 (Error 09) - Field Description

<i>Table 11-29. MOSS BER Type 01 ID 06 (Error 09) Field Description</i>		
Field Name	Meaning	Refer to
WKR3	For product engineering use	--
WKR4	For product engineering use	idem
WKR5	For product engineering use	idem
WKR6	For product engineering use	idem
WKR7	For product engineering use	idem
CA	CA error status	idem
LA	LA error status	idem

Note: The other registers are described in chapter 2 of this manual.

MOSS BER Type 01 ID 06 (Error 09) - Field Details

Some of the following fields may not appear on the ELD detail display, but they are part of the BER and they are listed as they appear in the BER file.

See the section 'BER Formats on Disk' page 11-112

<i>Table 11-30. MOSS BER Type 01 ID 06 (Err 09) Field Details</i>		
Field Name	Bit Pattern or Hex Value	Meaning
X71 bytes 0-1	xxxx xxxx xxxx xxxx	CA or Link address according to IOC bus format
X71 byte x	xx x x x x x x x	Unused CLDP abend RPO detected Load Dump CA IPL Link IPL
X72		Contains the CLDP codes.

MOSS BER Type 01 ID 06 (Error 13)

Format foM34: see page 11-119. This BER is generated to indicate that a timed IPL will occur soon.

```

                                ELD DETAIL
SEL#:hhhh FLAG:hh DATE:dd/dd TIME:dd:dd TYPE:01 ID:06
CP< error description line >          <REFER.CODE IN CHAR.> CCCCCCCC

MOSS-CHECK:13  CCU:hh
LOAD MODULE:xxxxxxx
TIMED IPL DATE/TIME:MM/DD/YY  HH:MM
REFERENCE DATE/TIME:MM/DD/YY  HH:MM

====>

F1:END F2:MENU2 F3:ALARM F4:SUMMARY F5:LIST F7:PREVIOUS F8:NEXT

```

MOSS BER Type 01 ID 06 (Error 14)

Format foM35: see page 11-119. This BER is generated when a timed IPL is cancelled.

```

                                ELD DETAIL
SEL#:hhhh FLAG:hh DATE:dd/dd TIME:dd:dd TYPE:01 ID:06
CP< error description line >          <REFER.CODE IN CHAR.> CCCCCCCC

MOSS-CHECK:14  CCU:hh
LOAD MODULE:xxxxxxx
TIMED IPL DATE/TIME:MM/DD/YY  HH:MM
REFERENCE DATE/TIME:MM/DD/YY  HH:MM
MOSS CANCEL ORIGIN:hh

====>

F1:END F2:MENU2 F3:ALARM F4:SUMMARY F5:LIST F7:PREVIOUS F8:NEXT

```

MOSS BER Type 01 ID 06 (Error 18)

Format foM47: see page 11-121. This BER is generated for a LSSD string firt part.

```

                                ELD DETAIL
SEL#:hhhh FLAG:hh DATE:dd/dd TIME:dd:dd TYPE:01 ID:06
CP< error description line >          <REFER.CODE IN CHAR.> CCCCCCCC

LSSD STRING: 192 bytes long

====>

F1:END F2:MENU2 F3:ALARM F4:SUMMARY F5:LIST F7:PREVIOUS F8:NEXT

```

MOSS BER Type 01 ID 06 (Error 28)

Format foM48: see page 11-121. This BER is generated for a LSSD string second part.

```

                                ELD DETAIL
SEL#:hhhh FLAG:hh DATE:dd/dd TIME:dd:dd TYPE:01 ID:06
CP< error description line >          <REFER.CODE IN CHAR.> CCCCCC

LSSD STRING: 317 bytes long

===>

F1:END F2:MENU2 F3:ALARM F4:SUMMARY F5:LIST F7:PREVIOUS F8:NEXT
    
```

MOSS BER Type 01 ID 06 (Errors 13 and 14) Field Description

<i>Table 11-31. MOSS BER Type 01 ID 06 (Errors 13 and 14) Field Details</i>		
Field Name	Bit Pattern or Hex Value	Meaning
CCU	hh = 01 hh = 02	CCU A CCU B
LOAD MODULE	xxxxxxx	Load module name (eight characters max)
TIMED IPL DATE/TIME	MM/DD/YY HH:MM	Date and time of the timed IPL
REFERENCE DATE/TIME	MM/DD/YY HH:MM	Host date and time reference when the timed IPL command is sent
MOSS CANCEL ORIGIN	hh = 01 hh = 02 hh = 03 hh = 04	Clock lost Too late MOSS not online IPL running on the other CCU

MOSS BER Type 01 ID 07

Format foM29: see page 11-118. The MOSS microcode generates the following BERs when an error occurs in the MOSS/TRSS interface.

```

                                ELD DETAIL
SEL#:hhh  FLAG 00 DATE:04/29 TIME:23:45  TYPE:01 ID:07
<ERROR DESCRIPTION>                                <REFER.CODE IN CHAR.> CCCCCC
ERROR:hh  TRA ADDR:hhh      X76:hhhhh
GET COMMAND COMPLETION:hhh
MOSS  ERROR STATUS:hhh
LEVEL1 ERROR STATUS:hhh
LEVEL2 ERROR STATUS:
TIC1:hhh  TIC2:hhh
TIC CTL REGISTER
bbbbbbb bbbbbbb

===>

F1:END F2:MENU2 F3:ALARM F4:SUMMARY F5:LIST F7:PREVIOUS F8:NEXT

```

Table 11-32. MOSS BER Type 01 ID 07 Field Details

Field Name	Bit Pattern or Hex Value	Meaning
ERROR	hh = 04 hh = 08 hh = 40 hh = 80	Error description No interrupt from TRM Error detected on level 1 Error detected on level 4 Error detected on level 1
TRA ADDR	hhh	TRA address, see page 3-46.
GET COMMAND COMPLETION	hhh	
MOSS ERROR STATUS	hhh	See page 6-24
LEVEL1 ERROR STATUS	hhh	See page 6-20
LEVEL2 ERROR STATUS TIC1 TIC2	hhh	See page 6-22
TIC CTL REGISTER	bbbbbbb bbbbbbb	

Format foM29a: see page 11-118. The MOSS microcode generates the following BERs when an error occurs on the MOSS/TRSS interface.

```

                                ELD DETAIL
SEL#:hhhh  FLAG 00 DATE:04/29 TIME:23:45  TYPE:01 ID:07
<ERROR DESCRIPTION>                <REFER.CODE IN CHAR.> CCCCCCCC
ERROR:hh  TRA INPUT ADDR:hhhh  TRA OUTPUT ADDR:hhhh
TIC NBR:hh
2K BLOC:  INITIAL   REQUESTED  FINAL
           hhhh     hhhh       hhhh
STOP COMMAND CNT:hh

===>

F1:END F2:MENU2 F3:ALARM F4:SUMMARY F5:LIST F7:PREVIOUS F8:NEXT
    
```

Table 11-33. MOSS BER Type 01 ID 07 Field Details

Field Name	Bit Pattern or Hex Value	Meaning
ERROR	00 FE	Error description TIC dump completed TIC set stg failure
TRA INPUT ADDR	hhhh	TRA input address from PCW
TRA OUTPUT ADDR	hhhh	TRA output address from PCW
TIC NBR	hh	TRP number
2K BLOC: INITIAL REQUESTED FINAL	hhhh hhhh hhhh	Initial block number Requested block number Final block number
STOP COMMAND CNT	hh	Stop command loop count

Format foM29b: see page 11-118. The MOSS microcode generates the following BERs when an error occurs on the MOSS/TRSS interface.

```

                                ELD DETAIL
SEL#:hhhh  FLAG 00 DATE:04/29 TIME:23:45  TYPE:01 ID:07
<ERROR DESCRIPTION>                <REFER.CODE IN CHAR.> CCCCCCCC
ERROR:FF  ERROR-EXT:hh  TRA NBR:hh  TIC NBR:hh
CCU:hh  TRA ADDR:hhhh

===>

F1:END F2:MENU2 F3:ALARM F4:SUMMARY F5:LIST F7:PREVIOUS F8:NEXT
    
```

Table 11-34. MOSS BER Type 01 ID 07 Field Details

Field Name	Bit Pattern or Hex Value	Meaning
ERROR extension	01 02 03 04 00	Error description Dump file full Disk error Hardware error Select TRA TIC error When the dump is available
TRA NBR	hh	TRA number (01-04)
TIC NBR	hh	TIC number (01-02)
CCU	hh	CCU 01 = CCUA 02 = CCUB
TRA ADDR	hhh	TRA address, see page 3-46.

MOSS BER Type 01 ID 08

Format foM16: see page 11-116. The MOSS microcode generates the following BERs when an error occurs on the MOSS/CA interface.

```

new BER not yet entered
                                ELD DETAIL
SEL#:hhhh  FLAG 00 DATE:dd/dd TIME:hh:hh  TYPE:01 ID:08
<ERROR DESCRIPTION>                <REFER.CODE IN CHAR.> CCCCCCCC
DUMP:hh TRACE:hh CA:hh  CCU:hh

===>

F1:END F2:MENU2 F3:ALARM F4:SUMMARY F5:LIST F7:PREVIOUS F8:NEXT

```

MOSS BER Type 01 ID 08 - Field Details

Table 11-35. MOSS BER Type 01 ID 08 Field Details

Field Name	Hex Value	Meaning
DUMP	00 01 02 03	Dump available Dump full Disk error Threshold. Maximum number of auto-dump (maximum value 5)
TRACE	00 01	Restart trace successful Restart trace failed
CA	xx	CA addresses, from 5 to 8
CCU	01	CCU (always set to 01)

MOSS BER Type 01 ID 0A

Format foM27a: see page 11-117. The MOSS microcode generates the following BER when an ESS dump is taken.

```

                                ELD DETAIL
SEL#:hhhh  FLAG 00 DATE:04/29 TIME:23:45  TYPE:01 ID:0A
<ERROR DESCRIPTION>                                <REFER.CODE IN CHAR.> CCCCCCCC
ERROR CODE:FF  ERROR-EXT:hh  ELA NBR:hh
ELA ERR STATUS:hh  CCU:hh

====>

F1:END F2:MENU2 F3:ALARM F4:SUMMARY F5:LIST F7:PREVIOUS F8:NEXT
    
```

MOSS BER Type 01 ID 0A - Field Details

Table 11-36. MOSS BER Type 01 ID 0A Field Details

Field Name	Bit Pattern or Hex Value	Meaning
ERR CODE	FF	Always set to FF
ERROR-EXT	00 01 02 03 Other	Error extension description Dump successfully completed Dump file already full Dump failed, disk error Dump failed, adapter error Dump failed, unknown cause
ELA NBR	hh	ELA number (01-08)
ELA ERR STATUS	hh	-
CCU	01	CCU (always set to 01)

MOSS BER Type 01 IDs 10 and 11

Format foM14: see page 11-116.

```

                                ELD DETAIL
SEL#:hhhh  DATE:dd/dd TIME:dd:dd  TYPE:01 ID:hh
< error description line >                                <REFER.CODE IN CHAR.> CCCCCCCC
IORB:hhhh hhhh hhhh hhhh hh hh hh hh hhhhhhhh CCCCCCCC
      hhhhhhhh hhhhhhhh hhhhhhhh hhhh hhhh hhhh hhhh hhhh

OC1:CCCCCCCC OC2:CCCCCCCC CCUF:CCCCCCCC CCUB:CCCCCCCC

====>

F1:END F2:MENU2 F3:ALARM F4:SUMMARY F5:LIST F7:PREVIOUS F8:NEXT
    
```

MOSS BER (IDs 15 to 17 and 1A to 1D)

MOSS BER Type 01 IDs 12, 13, and 14

Format foM15: see page 11-116.

```
                                ELD DETAIL
SEL#:hhhh  FLAG:hh  DATE:dd/dd TIME:dd:dd  TYPE:01  ID:hh
< error description line >          <REFER.CODE IN CHAR.> CCCCCCCC
IORB:hhhh  hhhh  hhhh  hhhh  hh  hh  hh  hh  hhhhhhhh  CCCCCCCC
      hhhhhhhh  hhhhhhhh  hhhhhhhh  hhhh  hhhh  hhhh  hhhh  hhhh
OC1:CCCCCCC  OC2:CCCCCCC  CCUF:CCCCCCC  CCUB:CCCCCCC

====>

F1:END F2:MENU2 F3:ALARM F4:SUMMARY F5:LIST F7:PREVIOUS F8:NEXT
```

The above screen shows the details of a MOSS BER ID 12

The IORB field pattern changes according to the BER ID:

ID 13

```
      hhhh  hhhh  hhhhhhhh  hh  hh  hh  hh  hhhhhhhh
      hhhhhhhh  hhhhhhhh  hhhh  hhhh  hh
```

ID 14

```
      hhhh  hhhh  hhhhhhhh  hh  hh  hh  hh  hhhhhhhh
```

MOSS BER Type 01 ID 15

Format foM30: see page 11-118. MOSS-CP interface (mailbox).

```
                                ELD DETAIL
SEL#:hhhh  FLAG:hh  DATE:dd/dd TIME:dd:dd  TYPE:01  ID:15
CP< error description line >          <REFER.CODE IN CHAR.> CCCCCCCC
IORB: hhhh  hhhh  hhhhhhhh  hh  hh  hh  hh  hhhhhhhh
      MRB: hhhhhhhh  hhhhhhhh  hhhhhhhh  hhhhhhhh
      hhhhhhhh  hhhhhhhh  hhhhhhhh  hhhhhhhh

OC1:CCCCCCC  OC2:CCCCCCC  CCUF:CCCCCCC  CCUB:CCCCCCC

====>

F1:END F2:MENU2 F3:ALARM F4:SUMMARY F5:LIST F7:PREVIOUS F8:NEXT
```

MOSS BER Type 01 IDs 16 and 1A to 1D

Format foM18: see page 11-116, MOSS-CP interface.

```

                                ELD DETAIL
SEL#:hhhh FLAG:hh DATE:dd/dd TIME:dd:dd TYPE:01 ID:16
CP< error description line >          <REFER.CODE IN CHAR.> CCCCCCCC

IORB: hhhh hhhh hhhhhhhh hh hh hh hh hhhhhhhh

OC1:CCCCCCCC OC2:CCCCCCCC CCUF:CCCCCCCC CCUB:CCCCCCCC

====>

F1:END F2:MENU2 F3:ALARM F4:SUMMARY F5:LIST F7:PREVIOUS F8:NEXT
    
```

Note: PLIST displayed only with BER ID 16.

MOSS BER Type 01 - ID 1E

This BER is generated when a LAN handler check occurs. Format foM36, see page 11-120.

```

                                ELD DETAIL
SEL# hhh  FLAG hh DATE:dd/dd TIME:dd:dd TYPE:01 ID:1E
<ERROR DESCRIPTION>          <REFER.CODE IN CHAR.> CCCCCCCC
IORB:hhhh hhhh hhhhhhhh hh hh hh hh hhhhhhhh hhhhhhhh
OC1:CCCCCCCC OC2:CCCCCCCC CCUF:CCCCCCCC CCUB:CCCCCCCC

====>

F1:END F2:MENU2 F3:ALARM F4:SUMMARY F5:LIST F7:PREVIOUS F8:NEXT
    
```

MOSS BER Type 01 IDs 10 to 16 and 1A to 1E - Field Description

Table 11-37. MOSS BER Type 01 ID 10 to 16 and 1A to 1D Field Description

Field Name	Meaning	Refer to
IORB	Disk input/output request block	PE only
MRB	Mailbox info	"
OC1	Operating control transient area overlay name 8 bytes	"
OC2	Operating control transient area module name 8 bytes	"
CCUF	CCU function transient area module name 8 bytes	"
CCUB	Unused	"

(*) For information on BERs originated by NCP/PEP, refer to the associated product documentation.

MOSS BER Type 01 ID 17

Format foM31: see page 11-119. The MOSS microcode generates the following BERs when an error occurs on the RSF function.

```

                                ELD DETAIL
SEL#:hhhh  FLAG 00 DATE:04/29 TIME:23:56  TYPE:01 ID:17
<ERROR DESCRIPTION>                                <REFER.CODE IN CHAR.> CCCCCCCC
MOSS-CHECK:hh  BCLE:hh  CMD:hh
                B STAT:hh A STAT:hh C STAT:hhhhhhh M STAT:hh

====>

F1:END F2:MENU2 F3:ALARM F4:SUMMARY F5:LIST F7:PREVIOUS F8:NEXT
    
```

MOSS BER Type 01 ID 17 - Field Description

<i>Table 11-38. MOSS BER Type 01 ID 17 Field Description</i>		
Field	Meaning	Refer to
A STAT	Adapter status register	page 11-61
B STAT	Adapter status register	page 11-61
BCLE	Buffer control list element	Page 11-86
CMD	Logical Cmd in the request function	Page 11-86
C STAT	Adapter status register	page 11-61
M STAT	Modem status	page 11-61
MOSS-CHECK	MOSS error code	page 11-62

MOSS BER Type 01 ID 19

BER format foM12: see page 11-115. BER for MOSS IML complete with error.

```

                                ELD DETAIL
SEL#:hhhh  FLAG:hh  DATE:dd/dd  TIME:dd:dd  TYPE:01  ID:19
< error description line >          <REFER.CODE IN CHAR.> CCCCCCCC
F:hh
PANEL NEW  REQ:hh  FCN:hh  SERV:hh
PANEL OLD  REQ:hh  FCN:hh  SERV:hh
HEXCODE:hhh hhh hhh hhh hhh hhh hhh hhh hhh hhh hhh hhh hhh hhh hhh
CDF-RC:hhhh
ECBDISK:hhhh MIOC  CCUA:hhhh  CCUB:hhhh
MB CCUA  CMD:hh  STAT:hhhh
MB CCUB  CMD:hh  STAT:hhhh

===>

F1:END F2:MENU2 F3:ALARM F4:SUMMARY F5:LIST F7:PREVIOUS F8:NEXT

```

MOSS BER Type 01 ID 19 - Field Description

<i>Table 11-39. MOSS BER Type 01 ID 19 Field Description</i>		
Field Name	Meaning	Refer to
CCUA	CCU function transient area module name 8 bytes	
CCUB	Unused	
CDF-RC	CDF return code. Normally 0000, otherwise PE only	For PE only
CMD	Logical Cmd in the request function	Page 8-15
ECBDISK	ECB on disk/diskette operation	PE only
F	Error code. Information is collected in case hexadecimal code cannot be displayed on the panel.	Page 11-88
MIOC	MIOC ECB for operation on CCUA/B	Page 11-87
CCUA/B		
PANEL	Hexa code sequence, from the oldest to the more recent one	
HEXCODE		
MB	<ul style="list-style-type: none"> Bytes 1 through 16 (hex 0 thru F): mailbox request zone (in/out) (first line on the screen) Bytes 17 through 32 (hex 10 thru 1F): mailbox response zone (IN/OUT) (second line of the screen) 	Page 8-15
PANEL NEW	Panel hex code	
PANEL OLD	Previous hex code	
REQ	Same as field 'ORIGI' in BER 01-20	Page 11-88
FCN	Selected function on control panel	Page 9-3
SEV	Service mode	Page 9-3
STAT	Mail box status	Page 11-87

MOSS BER Type 01 ID 20

Format foM21: see page 11-116. This BER corresponds to a general IPL successfully performed. Whatever the IPL trigger item is (control panel, KB/D, automatic, scheduled), this BER is logged at IPL completion.

This BER is logged for availability measurement purpose.

```

                                ELD DETAIL
SEL#:hhhh  FLAG:hh  DATE:dd/dd  TIME:dd:dd  TYPE:01  ID:20
CP< error description line >          <REFER.CODE IN CHAR.> CCCCCC
ORIGI:hh  FUNCTION:hh  SERV:hh  CCU:hh
STATUS:bbbbbbb  REQ:hh  LVLE-REQ:bbbbbbb
MODE:hh  DEFAULT:hh  CONF:hh

===>

F1:END F2:MENU2 F3:ALARM F4:SUMMARY F5:LIST F7:PREVIOUS F8:NEXT
    
```

MOSS BER Type 01 IDs 17, 19, and 20 - Field Details

Some of the following fields may not appear on the ELD detail display, but they are part of the BER and they are listed as they appear in the BER file. See the section 'BER Formats on Disk' page 11-112

Table 11-40 (Page 1 of 4). MOSS BER Type 01 IDs 17, 19, and 20 Field Details

Field Name	Bit Pattern or Hex Value	Meaning
BCLE	00	Buffer control list element
	01	Enable request
	03	Sense adapter request
	04	Read text/HDR request
	06	Bid preparation request
	0C	Write SOH...ETX
	10	Write bid request
	14	Write EOT request
	16	Disable request
	1E	Write STX...ETX
	3C	Write STX...ETB
CMD	3C	Write disconnected request
	80	Halt request flag
		Logical Cmd in the request function
	91	Connect
	80	Open
	40	Send
	20	Send/Receive
	08	Close
	04	Not used
	02	Receive for file Xfer
	01	Line survey

Table 11-40 (Page 2 of 4). MOSS BER Type 01 IDs 17, 19, and 20 Field Details

Field Name	Bit Pattern or Hex Value	Meaning
MIOC CCUA		MIOC ECB for operation on CCUA
Byte 1	00 80 40 20 10 08 04 02 01	Normal operation CC time out CC posted CC started CC BER CC warning CC adapter down CC request rejected CC I/O exception
Byte 2	40 41 42 43 61 62 63 64 65 66 67 68 69 6A 6B 6C 6D 6E 6F	No MCCU ID specified Invalid logical request Invalid PCW Channel I/O running Request truncated CCU busy bit On Failed IOC error NCP time out Mail box lock LSSD error residual count String select error No mail box allowed, CCU IPL Buffer empty MIOC/adapter busy bit On MOSS address exception MOSS OP check CHIO asynchronous error CHIO time out
STAT		Mail box status
Byte 1	80 40 20 10 08 04 02 01	Accepted Rejected Not used Not used Keep buffer Free buffer Not used Not used
Byte 2	80 40 20 10 08 04 02 01	Buffer not available Function not supported Invalid command Moss down or Off line Invalid parameters Fallback in process Not used Enable to queue SNA req.
MOSS-CHECK	01	IPL complete without errors

Table 11-40 (Page 3 of 4). MOSS BER Type 01 IDs 17, 19, and 20 Field Details		
Field Name	Bit Pattern or Hex Value	Meaning
ORIGI	<p>x</p> <p>. x</p> <p>. . x</p> <p>. . . x</p> <p>. . . . x</p> <p>. 1 . .</p> <p>. x .</p> <p>. x</p>	<p>Origin of MOSS code activation</p> <p>Machine power-ON</p> <p>Machine reset</p> <p>MOSS power-ON</p> <p>MOSS reset</p> <p>MOSS automatic re-IML</p> <p>Forced origin</p> <p>The origin of the ROS code activation is forced to the previous activation (for example: machine power ON, machine reset, MOSS power ON)</p> <p>NOTE: this bit is meaningful when a MOSS reset occurs before all the MOSS control blocks initialization by the IML processor.</p> <p>Forced selection.</p> <p>This bit is set ON when the MOSS diags cannot get from the MPWL valid information defining the origin, the function or service mode.</p> <p>In such a case default values are</p> <p>Origin: MOSS power ON</p> <p>Function: MOSS IML from disk</p> <p>Service: CE mode</p> <p>Unused</p>
F	<p>x</p> <p>. x</p> <p>. . xx</p> <p>. . . . xxx .</p> <p>. x</p>	<p>Error code</p> <p>IML not successful</p> <p>Alarm indicator A0 has to be generated</p> <p>Unused</p> <p>Operation with power failed for:</p> <p>x Get end of IML data</p> <p>. x . . . Get stacked error record</p> <p>. . x . . Panel hex display</p> <p>Unused</p>
FUNCTION	<p>00</p> <p>01</p> <p>02</p> <p>05</p> <p>07</p> <p>08</p> <p>09</p> <p>0A</p>	<p>Function selection</p> <p>General IPL with IML from disk</p> <p>MOSS IML from disk</p> <p>MOSS dump</p> <p>Remote console link test</p> <p>RSF console link test</p> <p>Local console link test</p> <p>Diskette mode</p> <p>Loop on MOSS diagnostics</p>
SERV	<p>00</p> <p>01</p> <p>02</p> <p>03</p>	<p>Service selection</p> <p>Normal Customer mode</p> <p>Maint 1 CE mode</p> <p>Maint 2 By-pass MOSS diags</p> <p>Maint 3 First installation</p>
CCU	<p>01</p>	<p>CCU (always set to 01)</p>
STATUS	<p>x</p> <p>. x</p>	<p>IPL mode (IPLMODE)</p> <p>x = 0 <==> Operator</p> <p>x = 1 <==> Automatic</p> <p>Customer / Maintenance (MTMENU)</p> <p>x = 0 <==> Customer</p> <p>x = 1 <==> Maintenance</p>

Table 11-40 (Page 4 of 4). MOSS BER Type 01 IDs 17, 19, and 20 Field Details

Field Name	Bit Pattern or Hex Value	Meaning
REQ	01 02 03 to 06 07 08 09 0A 0B 0C	IPL on power ON reset CCU + scanners IPL req from KB/D Unused IPL is requested by the level 1 Scheduled or network power ON reset IPL after fallback Manual fallback requested IPL of the stanby CCU requested Timed IPL requested
LVLE-REQ	0000 0010 0000 0111 0000 0011 0000 0100	Identification of CCU IPL request CCU hardcheck Output 70 received Program request IPL Channel request IPL
CONF	01	Always set to 01
DEFAULT	01	Always set to 01
MODE	01	Always set to 01

MOSS BER Type 01 ID 21

Format foM23: see page 11-117 This BER is logged for availability measurement purposes. This BER corresponds to an IPL requested from the KB/D.

```

                                ELD DETAIL
SEL#:hhhh  FLAG:hh  DATE:dd/dd  TIME:dd:dd  TYPE:01  ID:21
APPL < error description line >          <REFER.CODE IN CHAR.> CCCCCC
EVENT-EXT:hh
STATUS:bbbbbbb  CCU:hh

====>

F1:END F2:MENU2 F3:ALARM F4:SUMMARY F5:LIST F7:PREVIOUS F8:NEXT
    
```

MOSS BER Type 01 ID 21 Field Details

Some of the following fields may not appear on the ELD detail display, but they are part of the BER and they are listed as they appear in the BER file. See the section 'BER Formats on Disk' page 11-112

<i>Table 11-41. MOSS BER Type 01 ID 21 Field Details</i>		
Field Name	Bit Pattern or Hex Value	Meaning
EVENT-EXT	01	IPL
STATUS	xxxx xx x x	Unused IPL mode (IPLMODE) x = 0 <==> Operator x = 1 <==> Automatic Customer / Maintenance (MTMENU) x = 0 <==> Customer x = 1 <==> Maintenance
CCU	01	Always set to 01
CONFIG.	01	Always set to 01

MOSS BER Type 01 - ID 23

This BER is generated when a 37CS re-IML is completed. Format foM37, see page 11-120.

```

                                ELD DETAIL
SEL# hhh  FLAG hh DATE:dd/dd TIME:dd:dd  TYPE:01  ID:23
<ERROR DESCRIPTION>                                <REFER.CODE IN CHAR.> CCCCCC
CCU:hh

===>

F1:END  F2:MENU2  F3:ALARM  F4:SUMMARY  F5:LIST  F7:PREVIOUS  F8:NEXT

```

MOSS BER Type 01 - ID 2A

This BER is generated when an ESCA RE-IPL failed. Format fom38, see page 11-120.

```

                                ELD DETAIL
SEL# hhh  FLAG hh DATE:dd/dd TIME:dd:dd  TYPE:01  ID:2A
<ERROR DESCRIPTION>                                <REFER.CODE IN CHAR.> CCCCCC
TA:hh
SLID:hhhhhhh
CCU:hh

===>

F1:END  F2:MENU2  F3:ALARM  F4:SUMMARY  F5:LIST  F7:PREVIOUS  F8:NEXT

```

MOSS BER Type 01 - ID 2B

This BER is generated when a RE-IPL has started on a line, a CA, or an ESCA. Format foM39, see page 11-120.

```

                                ELD DETAIL
SEL# hhh  FLAG hh DATE:dd/dd TIME:dd:dd  TYPE:01  ID:2B
<ERROR DESCRIPTION>                                <REFER.CODE IN CHAR.> CCCCCC
TA BYTE 0:hh
TD BYTE 1:hh
CCU:hh
ORIGIN:hh

===>

F1:END  F2:MENU2  F3:ALARM  F4:SUMMARY  F5:LIST  F7:PREVIOUS  F8:NEXT

```

MOSS BER Type 01 - ID 2C

This BER is generated for a DL2 call completion. Format foM45, see page 11-121.

```

                                ELD DETAIL
SEL# hhh  FLAG hh DATE:dd/dd TIME:dd:dd  TYPE:01  ID:2C
<ERROR DESCRIPTION>                <REFER.CODE IN CHAR.> CCCCCC
COMPLETION CODE :hhhh
CPN :cccc
CCU :hh
REFERENCE CODE :cccccccc cccccccc cccccccc

===>

F1:END  F2:MENU2  F3:ALARM  F4:SUMMARY  F5:LIST  F7:PREVIOUS  F8:NEXT
    
```

MOSS BER Type 01 - ID 2D

This BER is generated for a CP dump transfer error, the dump is purged. Format foM46, see page 11-121.

```

                                ELD DETAIL
SEL# hhh  FLAG hh DATE:dd/dd TIME:dd:dd  TYPE:01  ID:2D
<ERROR DESCRIPTION>                <REFER.CODE IN CHAR.> CCCCCC
CCU :hh
REASON :hh

===>

F1:END  F2:MENU2  F3:ALARM  F4:SUMMARY  F5:LIST  F7:PREVIOUS  F8:NEXT
    
```

MOSS BER Type 01 - ID 2E

This BER is generated for a CP dump transfer error, the dump is purged. Format foM50, see page 11-122.

```

                                ELD DETAIL
SEL# hhh  FLAG hh DATE:dd/dd TIME:dd:dd  TYPE:01  ID:2E
<ERROR DESCRIPTION>                <REFER.CODE IN CHAR.> CCCCCC
IML ORIGIN :hh
LOW ADDR :hh
HIGH ADDR :hh
ADNO :hh

===>

F1:END  F2:MENU2  F3:ALARM  F4:SUMMARY  F5:LIST  F7:PREVIOUS  F8:NEXT
    
```

MOSS BER Type 01 ID 23 and 2A to 2E Field Details

Field Name	Hex Value	Meaning
ADNO		LAN or ESCA adapter number

Field Name	Hex Value	Meaning
CCU	00	CCU A and B
	01	CCU A
	02	CCU B
IML ORIGIN	01	General 3746-900 IML
	02	LAN selective IML
	03	ESCA selective IML
ORIGIN	01	Re-IPL started on line xxxx (Alarm = 15)
	02	Re-IPL started on CA xxxx (Alarm = 17)
	03	Re-IPL started on ESCA xxxx (Alarm = 18)
	Other	Re-IPL started from RLA process xxxx (Alarm = 16)
SLID		System logical ID
TA		Page 3-36
TD		Page 3-36
COMPLETION CODE	01	Call RETAIN not successful
	02	Call RETAIN not authorized
	03	Call RETAIN OK hardware problem
	04	Call RETAIN OK microcode problem plus fix down loaded to MOSS-E
	05	Call RETAIN OK microcode problem without fix
CPN	ccc	Customer problem number
REASON	01	LAN error, link down
	02	MOSS-E microcode error
	03	HDD disk error
	04	Umacht block number
	05	Re-IML during transfer
REFERENCE CODE		Reference code reported to RETAIN

MOSS BER Type 01 IDs 24 to 29, and 37

Format foM24: see page 11-117. CA concurrent maintenance BER.

```
                                ELD DETAIL
SEL#:hhhh  FLAG:hh  DATE:dd/dd  TIME:dd:dd  TYPE:01  ID:hh
APPL < error description line >          <REFER.CODE IN CHAR.> CCCCCC
CA:hh

====>

F1:END F2:MENU2 F3:ALARM F4:SUMMARY F5:LIST F7:PREVIOUS F8:NEXT
```

MOSS BER Type 01 ID 30

Format foM25: see page 11-117. Adapter error.

```
                                ELD DETAIL
SEL#:hhhh  FLAG:hh  DATE:dd/dd  TIME:dd:dd  TYPE:01  ID:30
APPL < error description line >          <REFER.CODE IN CHAR.> CCCCCC
FRU GROUP:hhhh

====>

F1:END F2:MENU2 F3:ALARM F4:SUMMARY F5:LIST F7:PREVIOUS F8:NEXT
```

MOSS BER Type 01 ID 32

Format foM27: see page 11-117. MCAD error.

```
                                ELD DETAIL
SEL#:ddd   FLAG:hh  DATE:dd/dd  TIME:dd:dd  TYPE:01  ID:32
APPL < error description line >          <REFER.CODE IN CHAR.> CCCCCC
PLIST:hhhhhhh PRB:hhhhhhh DATA:hh  CMND:hhhh  ERR:hhh

====>

F1:END F2:MENU2 F3:ALARM F4:SUMMARY F5:LIST F7:PREVIOUS F8:NEXT
```

MOSS BER Type 01 IDs 30, and 32 - Field Description

Table 11-42. MOSS BER Type 01 IDs 30, 32 Field Description		
Field Name	Meaning	Refer to
FRU GROUP	List of FRUs to exchange	MIP Chapter 1
PLIST	Pointer to IORB list	
PRB	Current IORB pointer value	Page 11-21 Page 11-59 (ARC)
SRB	Unused	
FRU GROUP	Part of the reference code	
ERR	Return code from adapter	
DISC	Unused	
DATA	Data sent to adapter	
CMD	Command sent to adapter	

MOSS BER, Type 01 ID 36

Cyclic hour notification

```

                                ELD DETAIL
SEL#:ddd  FLAG:hh  DATE:dd/dd  TIME:dd:dd  TYPE:01  ID:36
APPL < error description line >          <REFER.CODE IN CHAR.> CCCCCCCC

====>

F1:END F2:MENU2 F3:ALARM F4:SUMMARY F5:LIST F7:PREVIOUS F8:NEXT
    
```

MOSS BER Type 01 ID 38

Format foM28: see page 11-118. CA concurrent maintenance NCP request to cancel

```

                                ELD DETAIL
SEL#:ddd  FLAG:hh  DATE:dd/dd  TIME:dd:dd  TYPE:01  ID:38
APPL < error description line >          <REFER.CODE IN CHAR.> CCCCCCCC
ERR1:hhhh  ERR2:hhhh

====>

F1:END F2:MENU2 F3:ALARM F4:SUMMARY F5:LIST F7:PREVIOUS F8:NEXT
    
```

MOSS BER Type 01 ID 39

Format foM33: see format page 11-119. MMIO interface.

```

                                ELD DETAIL
SEL#:ddd  FLAG:hh  DATE:dd/dd  TIME:dd:dd  TYPE:01  ID:39
APPL < error description line >          <REFER.CODE IN CHAR.> CCCCCC
IOIRV:hh  PIRV:hh  PIC: STATUS:hh  REQ:hh

====>

F1:END F2:MENU2 F3:ALARM F4:SUMMARY F5:LIST F7:PREVIOUS F8:NEXT
    
```

MOSS BER Type 01 IDs 38 and 39 - Field Description

<i>Table 11-43. MOSS BER Type 01 IDs 38 and 39 Field Description</i>		
Field Name	Meaning	Refer to
ERROR 1	Error code 1 (contains CCU-OUTPUT X57 request from NCP)	Page 11-96
ERROR 2	Error code 2 (contains CCU-INPUT X57 return from MOSS)	Page 11-96
IOIRV	I/O interrupt request vector	Page 11-44
PIRV	Program interrupt request vector	Page 11-44
PIC	Controller IPL type	
REQ	Mailbox information	

MOSS BER Type 01 IDs 38 and 39 - Field Details

<i>Table 11-44. MOSS BER Type 01 ID 39 Field Details</i>		
Field Name	Bit Pattern or Hex Value	Meaning
CCU INPUT X57 Byte 0	x x x x xxxx	CA 5 MOSS request pending CA 6 MOSS request pending CA 7 MOSS request pending CA 8 MOSS request pending Unused
Byte 1		Unused
CCU OUTPUT X57 Byte 0	x x x x xxxx	Set/reset CA 5 MOSS request Set/reset CA 6 MOSS request Set/reset CA 7 MOSS request Set/reset CA 8 MOSS request Unused
Byte 1		Unused.

MOSS BER Type 01 ID 43

This BER gives complementary information to BER type 01 ID 30.

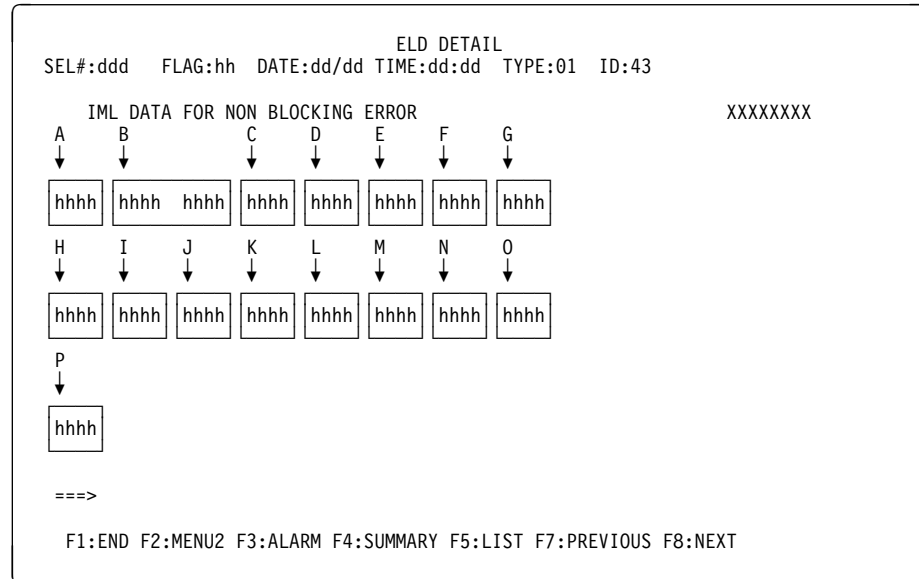

Note: The representation of this BER is modified for explanatory purpose. On the MOSS display screen, only data lines (hhhh in the picture) are shown.

MOSS BER Type 01 ID 43 - Field Details

The data are displayed in hexadecimal form. The next table gives the bit correspondance of the fields referenced in the previous picture.

Field Name	Bit Pattern	Meaning
A		Panel and Miscellaneous Warnings
Byte 1	x x x x x x x x	Problem suspected with hexadecimal display ROS 8K entry wrongly selected Information from panel not valid TOD not operative Single error threshold is reached Spare bit of MSC is used Spare bit test not successfull Display requested at end of IML
Byte 2		Unused
B		Test of the 3 PCAs
Byte 1	x x x x	PCAs state PCA1 test unsuccessfull (local) PCA2 test unsuccessfull (remote/alternate) PCA3 test unsuccessfull (RSF)
	. . . x	Unused

<i>Table 11-45 (Page 2 of 5). MOSS BER Type 01 ID 43 Field Details</i>		
Field Name	Bit Pattern	Meaning
Byte 2	X	PCA1 warnings
	. X	Hardwired values impossible in PCA1
	. . X	Error in PCA1 test asynchronous
	. . . X	Unexpected level 0 IR in PCA1 test
 X	PCA1 internal wrap asynchronous test KO
 X	Unexpected interrupt during PCA1 test
 xxx	Unused
Byte 3	X	PCA2 warnings
	. X	Hardwired values impossible in PCA2
	. . X	Error in PCA2 test asynchronous
	. . . X	Unexpected level 0 IR in PCA2 test
 X	PCA2 internal wrap asynchronous test KO
 X	Unexpected interrupt during PCA2 test
 xxx	Unused
Byte 4	X	PCA3 warnings
	. X	Hardwired values impossible in PCA3
	. . X	Error in PCA3 test asynchronous
	. . . X	Unexpected level 0 IR in PCA3 test
 X	PCA3 internal wrap asynchronous test KO
 X	Unexpected interrupt during PCA3 test
 xxx	Unused
C to P		MCAC test warnings
C		IPL and adapters information
Byte 1	X	Unused
	. X	MCAD KO
	. . X	Unused
	. . . X	MCCU KO
 xx	Unused
 X	IPL not possible on CCU
 X	Unused
Byte 2	X	Unused
	. X	MCAD usable
	. . X	Unused
	. . . X	MCCU usable
 xxxx	Unused
D		
Byte 1	X	MCAD errors
	. X	Valid PIO unrecognised by MCAD
	. . X	Valid PIO unrecognised by MCAD
	. . . X	Unused
 X	CADS HLIR bit not expected
 X	Unused
 X	CADS LLIR bit unexpected
Byte 2 xx	Unused
	X	MCAD detection information
	. X	Unused
	. . X	No error detection allowed
	. . . X	Bad pty not found in MCAD/MOSS processor
 X	Invalid PIO command not detected
 X	Unused
 X	Error in MCAD not reported to MOSS processor
 X	Parity error in MCAD during a write
 X	Parity error in MOSS processor during a read
E		

<i>Table 11-45 (Page 3 of 5). MOSS BER Type 01 ID 43 Field Details</i>		
Field Name	Bit Pattern	Meaning
Byte 1	x x x x xxxx	MCAD reporting MCAD IR 4 not reported to MOSS processor No CADS HLIR reporting in MCAD Unused No CADS LLIR reporting in MCAD Unused
Byte 2	x x x x x x x x x x	CADS actions information All CA disabled, sense bit KO CADS MOSS power-ON reset bit ON Unused Validation of enable and reset CADS not possible Unused Reset of CADS not possible Nohold bit ON in CAMPOR register Force error bits ON in MCAD
F		Reset CADS information
Byte 1	xxxx x x x x x	Unused M reset CADS 5 ON M reset CADS 6 ON M reset CADS 7 ON M reset CADS 8 ON
Byte 2		Unused
G		Enable CADS possibilities
Byte 1	xxxx x x x x x	Unused Enable CADS 5 not possible Enable CADS 6 not possible Enable CADS 7 not possible Enable CADS 8 not possible
Byte 2		Unused
H		Reset CADS possibilities
Byte 1	xxxx x x x x x	Unused Reset CADS 5 not possible Reset CADS 6 not possible Reset CADS 7 not possible Reset CADS 8 not possible
Byte 2		Unused
I		Enable CADS information
Byte 1	xxxx x x x x x	Unused Enable CADS 5 ON Enable CADS 6 ON Enable CADS 7 ON Enable CADS 8 ON
Byte 2		Unused
J		Sense CA enabled information
Byte 1		

Table 11-45 (Page 4 of 5). MOSS BER Type 01 ID 43 Field Details		
Field Name	Bit Pattern	Meaning
	xxxx x x x x	Unused Sense CA 5 enabled at machine power-ON or machine reset Sense CA 6 enabled at machine power-ON or machine reset Sense CA 7 enabled at machine power-ON or machine reset Sense CA 8 enabled at machine power-ON or machine reset
K		Sense CA information
Byte 1	xxxx x x x x	Sense CA KO information Unused Sense CA enabled 5 not OK Sense CA enabled 6 not OK Sense CA enabled 7 not OK Sense CA enabled 8 not OK
Byte 2	xxxx x x x x	Sense CA presence KO information Unused Sense CADS 5 presence not OK Sense CADS 6 presence not OK Sense CADS 7 presence not OK Sense CADS 8 presence not OK
L		CADS interface state
Byte 1	xxxx x x x x	Unused Interface with CADS 5 KO Interface with CADS 6 KO Interface with CADS 7 KO Interface with CADS 8 KO
Byte 2		Unused
M		Miscellaneous MCAD errors
Byte 1	xx x x xxxx	Unused M force error impossible in MCAD Unused
Byte 2		Unused
N		MCCU errors
Byte 1	x x x x x xxx	Valid PIO unrecognised by MCCU Valid PIO unrecognised by MCCU IOC tag reset function KO Unused IOC bus disabled by MCCU Unused
Byte 2	x x x x x x x x	MCCU error detection Unused No error detection possible No CCU HLIR detection possible No CCU LLIR detection possible No CSP LLIR detection possible MIOC time out counter down Bad pty not forced in MCCU, or MOSS processor Unused
O		MCCU errors

Table 11-45 (Page 5 of 5). MOSS BER Type 01 ID 43 Field Details		
Field Name	Bit Pattern	Meaning
Byte 1	x x x x x x xx	MCCU error detection Unused MCCU IR 0 not reported to MOSS processor MCCU IR 1 not reported to MOSS processor MCCU IR 4 not reported to MOSS processor IR level 4 not possible in MCCU MIOC time out not detected
Byte 2	x x x x x x x x	Unused MCCU data transfer error Interface MCCU and CCU KO Wrap test failed on MCCU MCCU data transfer not possible No 'CYCLE STEAL END IR' possible MCCU CHIO transfer not possible Unused MOSS INOP line not operative MOSS INOP reset not OK
P		MCCU miscellaneous
Byte 1	x x x x x x x x	M MIOC interface sense bits KO M force errors not possible Unused M PGM WAIT signal wrong in MCCU M card ID not available for MCC M IOC tag reset function unusable M disable IOC bus not usable M watchdog mechanism KO in MCCU
Byte 2		Unused

MOSS BER Type 01 ID 44

```

ELD DETAIL
SEL#:ddd  FLAG:hh  DATE:dd/dd  TIME:dd:dd  TYPE:01  ID:44

MOSS CODE DATA FOR PROBLEM ISOLATION
CCCCCCCC hhhhhhhh hhhhhhhh hhhhhhhh hhhhhhhh hhhhhhhh hhhhhhhh hhhhhhhh
hhhhhhh hhhhhhhh hhhhhhhh hhhhhhhh hhhhhhhh hhhhhhhh hhhhhhhh hhhhhhhh
hhhhhhh hhhhhhhh hhhhhhhh hhhhhhhh hhhhhhhh hhhhhhhh hhhhhhhh hhhhhhhh
hhhhhhh hhhhhhhh hhhhhhhh hhhhhhhh hhhhhhhh hhhhhhhh hhhhhhhh hhhhhhhh
hhhhhhh hhhhhhhh hhhhhhhh hhhhhhhh hhhhhhhh hhhhhhhh hhhhhhhh hhhhhhhh
hhhhhhh hhhhhhhh hhhhhhhh hhhhhhhh hhhhhhhh hhhhhhhh hhhhhhhh hhhhhhhh
hhhhhhh hhhhhhhh hhhhhhhh hhhhhhhh hhhhhhhh hhhhhhhh hhhhhhhh hhhhhhhh

===>

F1:END F2:MENU2 F3:ALARM F4:SUMMARY F5:LIST F7:PREVIOUS F8:NEXT

```

MOSS BER (IDs 50 to C2)

MOSS BER Type 01 ID 44 - Field Description

This BER is for PE only; no details are given about the meaning of the data displayed. It is not a failure BER or an error BER, it is an additional information for other BERs. The first 8 bytes contains the name of the control section at the origin of the BER logging. The contents of the 248 remaining bytes depends on the origin of the request. The screen displays '*****' for the unused bytes.

MOSS BER Type 01 ID 50

This BER is logged after three unsuccessful sign ON attempts on the remote console. There is no data in this BER. It only displays the message:

```
REMOTE CONSOLE REJECTED
```

MOSS BER Type 01 ID 80

See MOSS BER Type 01 ID 00, 11-39

MOSS BER Type 01 IDs 91, B3, C1, C2

Format foM8: see page 11-114.

The NCP/PEP program level 4 generates BERs 91, B3, C1, and C2 if a MOSS error occurs during a mailbox exchange. This BER is transferred to MOSS if MOSS successfully recovers from the MOSS error.

These BERs should always be accompanied by MOSS BER IDs 00, 01, 02, or 03. When BER ID 91 is not accompanied by one of these BERs, it only means that the MOSS has been inoperative during a period of time (MOSS re-IML, MOSS dump) and the BER ID is logged for information only.

```
                                ELD DETAIL
SEL#:ddd  FLAG:hh  DATE:dd/dd  TIME:dd:dd  TYPE:01  ID:hh
CP< error description line >          <REFER.CODE IN CHAR.> CCCCCCCC
MB:hh hh  hhhh hh  hhhhhh hhhh hhhh hhhh hhhh
      hhhh hh  hhhhhh hhhh hhhhhhhh hhhhhhhh

===>

F1:END F2:MENU2 F3:ALARM F4:SUMMARY F5:LIST F7:PREVIOUS F8:NEXT
```

MOSS BER Type 01 - ID A0

This BER is generated for a MOSS/MOSS-E token ring adapter error. Format fom40, see page 11-120.

```

                                ELD DETAIL
SEL# hhh  FLAG hh DATE:dd/dd TIME:dd:dd  TYPE:01  ID:A0
<ERROR DESCRIPTION>                                <REFER.CODE IN CHAR.> CCCCCC
ERROR CODE :hhh
PANEL CODE :ccc
IML REQUEST :hhhhh
MOSS MODEL :hh
DIAG STATUS :hhhhhhh

===>

F1:END  F2:MENU2  F3:ALARM  F4:SUMMARY  F5:LIST  F7:PREVIOUS  F8:NEXT

```

MOSS BER Type 01 - ID A1

This BER is generated for a MOSS/MOSS-E link problem. Format fom41, see page 11-120.

```

                                ELD DETAIL
SEL# hhh  FLAG hh DATE:dd/dd TIME:dd:dd  TYPE:01  ID:A0
<ERROR DESCRIPTION>                                <REFER.CODE IN CHAR.> CCCCCC
REASON :hh
PANEL CODE :ccc

===>

F1:END  F2:MENU2  F3:ALARM  F4:SUMMARY  F5:LIST  F7:PREVIOUS  F8:NEXT

```

MOSS BER Type 01 - ID A2

This BER is generated for a MOSS/MOSS-E link re-opened problem. Format fom42, see page 11-120.

```

                                ELD DETAIL
SEL# hhh  FLAG hh DATE:dd/dd TIME:dd:dd  TYPE:01  ID:A2
<ERROR DESCRIPTION>                                <REFER.CODE IN CHAR.> CCCCCC
OLD PANEL CODE :ccc

===>

F1:END  F2:MENU2  F3:ALARM  F4:SUMMARY  F5:LIST  F7:PREVIOUS  F8:NEXT

```

MOSS BER Type 01 - ID A3

Format fom43, see page 11-121.

This BER is generated for an invalid PICA message

```

                                ELD DETAIL
SEL# hhh  FLAG hh DATE:dd/dd TIME:dd:dd  TYPE:01  ID:A3
<ERROR DESCRIPTION>                                <REFER.CODE IN CHAR.> CCCCCC
MOSSCHK :01  SLID :hhhhhhh
YYSTATUS :hh  TYPE :hh
CAUSE :hh  IA :hhhhhhh
RCV MSG :hhhhhhh hhhhhhhh hhhhhhhh hhhhhhhh hhhhhhhh hhhhhhhh
          hhhhhhhh hhhhhhhh hhhhhhhh hhhhhhhh hhhhhhhh hhhhhhhh
          hhhhhhhh hhhhhhhh hhhhhhhh hhhhhhhh hhhhhhhh hhhhhh

===>

F1:END  F2:MENU2  F3:ALARM  F4:SUMMARY  F5:LIST  F7:PREVIOUS  F8:NEXT
```

This BER is generated for a FSM error

```

                                ELD DETAIL
SEL# hhh  FLAG hh DATE:dd/dd TIME:dd:dd  TYPE:01  ID:A3
<ERROR DESCRIPTION>                                <REFER.CODE IN CHAR.> CCCCCC
MOSSCHK :02  SLID :hhhhhhh
YYSTATUS :hh  TYPE :hh
IA :hhhhhhh
RCV MSG :hhhhhhh hhhhhhhh hhhhhhhh hhhhhhhh hhhhhhhh hhhhhhhh
          hhhhhhhh hhhhhhhh hhhhhhhh hhhhhhhh hhhhhhhh hhhhhhhh
          hhhhhhhh hhhhhhhh hhhhhhhh hhhhhhhh hhhhhhhh hhhhhh

===>

F1:END  F2:MENU2  F3:ALARM  F4:SUMMARY  F5:LIST  F7:PREVIOUS  F8:NEXT
```

This BER is generated for an invalid routing

```

                                ELD DETAIL
SEL# hhh  FLAG hh DATE:dd/dd TIME:dd:dd  TYPE:01  ID:A3
<ERROR DESCRIPTION>                                <REFER.CODE IN CHAR.> CCCCCC
MOSSCHK :03  SLID :hhhhhhh
TRANID :hhhhhhh  RESPONSE :hhhhhhh
IA :hhhhhhh

===>

F1:END  F2:MENU2  F3:ALARM  F4:SUMMARY  F5:LIST  F7:PREVIOUS  F8:NEXT
```

This BER is generated for an invalid server name

```

                                ELD DETAIL
SEL# hhh  FLAG hh DATE:dd/dd TIME:dd:dd  TYPE:01  ID:A3
<ERROR DESCRIPTION>                <REFER.CODE IN CHAR.> CCCCCCCC
MOSSCHK :04  SLID :hhhhhhhh
TRANID :hhhhhhhh  TYPE :hh
SERVER NAME :cccccccc  IA :hhhhhhhh

===>

F1:END  F2:MENU2  F3:ALARM  F4:SUMMARY  F5:LIST  F7:PREVIOUS  F8:NEXT

```

This BER is generated for an unmatched SSA response

```

                                ELD DETAIL
SEL# hhh  FLAG hh DATE:dd/dd TIME:dd:dd  TYPE:01  ID:A3
<ERROR DESCRIPTION>                <REFER.CODE IN CHAR.> CCCCCCCC
MOSSCHK :05  SLID :hhhhhhhh
TRANID :hhhhhhhh  REQUEST :hh hhhhhhhh hhhhhhhh
RESPONSE :hhhhhhhh  IA :hhhhhhhh

===>

F1:END  F2:MENU2  F3:ALARM  F4:SUMMARY  F5:LIST  F7:PREVIOUS  F8:NEXT

```

This BER is generated for an expected message not received

```

                                ELD DETAIL
SEL# hhh  FLAG hh DATE:dd/dd TIME:dd:dd  TYPE:01  ID:A3
<ERROR DESCRIPTION>                <REFER.CODE IN CHAR.> CCCCCCCC
MOSSCHK :06  SLID :hhhhhhhh
TRANID :hhhhhhhh  YSTATUS :hh
CAUSE :hh  REQUEST :hh hhhhhhhh hhhhhhhh
IA :hhhhhhhh

===>

F1:END  F2:MENU2  F3:ALARM  F4:SUMMARY  F5:LIST  F7:PREVIOUS  F8:NEXT

```

MOSS BER (IDs 50 to C2)

MOSS BER Type 01 - ID A4

This BER is generated by a LAN interface code (MOSS level 3). Format fom44, see page 11-121.

```

                                ELD DETAIL
SEL# hhh  FLAG hh DATE:dd/dd TIME:dd:dd  TYPE:01  ID:A4
<ERROR DESCRIPTION>                                <REFER.CODE IN CHAR.> CCCCCC
MOSSCHK :hh REASON :hh
MAJRQCOD :hh MINRQCOD :hh MAJRCCOD :hh
MINRCCOD :hh OPENERRC :hhh
RINGSTAT :hhh  LINKSTAT :hhh
LAN STATUS :hh LAN MANAGER STATUS :hh
IA :hhhhhhh  MAC ADDRESS :hhh hhhhhh

                                PAGE 1 OF 2

===>

F1:END F2:MENU2 F3:ALARM F4:SUMMARY F5:LIST F7:PREVIOUS F8:NEXT
```

This second page is generated when DLC or MAC counters are different of zero and when one of the MAC counters is ≥ 80 , or when XMIT ERR or RCVD ERR counter is ≥ 80 .

```

                                ELD DETAIL
SEL# hhh  FLAG hh DATE:dd/dd TIME:dd:dd  TYPE:01  ID:A4
<ERROR DESCRIPTION>                                <REFER.CODE IN CHAR.> CCCCCC
                                DLC COUNTERS
XMIT COUNT :hhh  RCVD COUNT :hhh  XMIT ERR :hh  RCVD ERR :hh
T1 EXPIRED :hhh  RCVD CMD :hh  SEND CMD :hh  PRMY STATE :hh
SCDY STATE :hh  STATION VS :hh  STATION VR :hh  STATION VA :hh
                                MAC ERR COUNTERS
LINE :hh  INTERNAL :hh  BURST :hh  ARI/FCI :hh
ABORT DELIMITER :hh  LOST FRAME :hh  RECEIV CONGESTION :hh
FRAME COPIED :hh  FREQUENCY :hh  TOKEN :hh

                                PAGE 2 OF 2

===>

F1:END F2:MENU2 F3:ALARM F4:SUMMARY F5:LIST F7:PREVIOUS F8:NEXT
```

This second page is generated when the MAC counters are = to zero and when one DLC counter is different of zero.

```

                                ELD DETAIL
SEL# hhh  FLAG hh DATE:dd/dd TIME:dd:dd  TYPE:01  ID:A4
<ERROR DESCRIPTION>                                <REFER.CODE IN CHAR.> CCCCCC
                                DLC COUNTERS
XMIT COUNT :hhh  RCVD COUNT :hhhh  XMIT ERR :hh   RCVD ERR :hh
T1 EXPIRED :hhh  RCVD CMD :hh     SEND CMD :hh   PRMY STATE :hh
SCDY STATE :hh   STATION VS :hh    STATION VR :hh  STATION VA :hh

                                PAGE 2 OF 2

===>

F1:END  F2:MENU2  F3:ALARM  F4:SUMMARY  F5:LIST  F7:PREVIOUS  F8:NEXT

```

This second page is generated when the DLC counters are = to zero and when one MAC counter is different of zero.

```

                                ELD DETAIL
SEL# hhh  FLAG hh DATE:dd/dd TIME:dd:dd  TYPE:01  ID:A4
<ERROR DESCRIPTION>                                <REFER.CODE IN CHAR.> CCCCCC
                                MAC ERR COUNTERS
LINE :hh          INTERNAL :hh   BURST :hh          ARI/FCI :hh
ABORT DELIMITER :hh  LOST FRAME :hh  RECEIV CONGESTION :hh
FRAME COPIED :hh    FREQUENCY :hh   TOKEN :hh

                                PAGE 2 OF 2

===>

F1:END  F2:MENU2  F3:ALARM  F4:SUMMARY  F5:LIST  F7:PREVIOUS  F8:NEXT

```

MOSS BER Type 01 IDs A0 to A4 - Field Description

Field Name	Meaning	Refer to
ERROR CODE	Error code	See page 11-109
PANEL CODE	Control panel code	MIP Chapter 1
IML REQUEST	IML request	
	Byte 1 = Origin	See page 11-109
	Byte 2 = Fonction	See page 11-109
	Byte 3 = Service	See page 11-109
MOSS MODEL	MOSS model	See page 11-109
DIAG STATUS	Diagnostic status	*
REASON CODE	Reason code	See page 11-110
MOSSCHK	MOSS check	See page 11-110
SLID	System logical identification	-
TRANID	Transaction identification	-
YYSTATUS	Lan status (open phase)	See page 11-110
TYPE	FRB type in error	See page 11-111
CAUSE	MOSS check cause	See page 11-111
REQUEST	Previous request summary	*
RESPONSE	SSA command header	*
SERVER NAME	Server name	-
IA	Instruction address	-
MAJRQCOD	Major request code	*
MINRQCOD	Minor request code	*
MAJRCCOD	Major return code	*
MINRCCOD	Minor return code	*
OPENERRC	Open error code	*
RINGSTAT	Ring status	*
LINKSTAT	Link status	*
LAN STATUS	LAN status	*
LAN MANAGER STATUS	LAN manager status	*
MAC ADDRESS	MAC address	-
T1 EXPIRED	T1 timer expired counter	-
PRMY STATE	Primary state counter	-
SCDY STATE	Secondary state counter	-
STATION VS	Station VS counter	-
STATION VR	Station VR counter	-
STATION VA	Station VA counter	-

* = PE only

MOSS BER (IDs 50 to C2)

<i>Table 11-46 (Page 2 of 3). MOSS BER Type 01 IDs A1 to A4 Field Details</i>		
Field Name Hex Value	Meaning	
REASON	8D 8E 8F 90 91 92 93 94 95 96 97 98 99 9A 9B 9C 9D 9E 9F B0 B1 B2 B3 B4 B5 B6 C0 C1 C2 C3 C4 D0	Solid MMIO error Intermittent MMIO error Adapter check Hardware initialization error Microcode error Lobe media test failure Signal loss while opening Wire fault while opening Open frequency error Time-out while opening Ring failure while opening Ring beaconing while opening Duplicate node address Open request parameters Open remove received Open IMPL force received No monitor for RPL at open Lobe wire fault at open Remote station connect time-out Link lost DM/DISC received/acknowledged FRMR received SABME received TI timer expired FRMR sent Unexpected SABME received Permanent ring beaconing Lobe wire fault Auto removal while beacon Remove received Auto removal FSM time-out
MOSSCHK (BER 01 ID A3)	01 02 03 04 05 06	Invalid PICA message FSM error Invalid routing Invalid server name Unmatched SSA response Expected message not received
MOSSCHK (BER 01 ID A4)	01 02 03 04	MOSS/MOSS-E link hardware problem MOSS/MOSS-E link microcode problem Excessive MAC soft error or Excessive DLC soft error or DLC/MAC statistic adapter counters or I-frame counters overflow or MAC error counters overflow Frame lost on MOSS/MOSS-E link
YYSTATUS	01 02 03 04 05 06 07 08 09 0A	Closed Adapter opened Found detected IML complete OK detected Link connected Service connection opened Connection opened Dialog created SSA-UP

Table 11-46 (Page 3 of 3). MOSS BER Type 01 IDs A1 to A4 Field Details

Field Name Hex Value	Meaning	
TYPE	01 02 03 04	PICA SSA Server connect Server disconnect
CAUSE	01 02 03 04 05 06	Not supported ILTOP Not supported POC Invalid path value Not supported PICA message SSA time-out FSM time-out

BER Formats on Disk

BERs Printed on Host

The length of the BERs printed from the disk on the host is not significant. When the BER detail is displayed on the console display, only the useful information is given. The remaining BER bytes, if any, printed but not displayed, have no meaning. Do not try to interpret them, they may lead to erroneous actions.

MOSS BERs Type 01 Formats

Format: foM0		Format: foM1	
ID: 00		ID: 01	
Byte	Meaning	Byte	Meaning
1-27	Header	1-27	Header
28-29	TYPE-ID	28-29	TYPE-ID
30-31	MOSS CHECK	30	ABEND
32-33	Action code	31	Flag
34-35	Hexadecimal code	32-33	WHO/WHAT - CHECK
36	EIRV	34-35	Recovery action
37-38	DIV	36-47	MCCUA REGS
39	IORV	48	CCUA CMSA
40	PIRV	49-51	CCUA X75
41	CPLLPL	52-54	CCUA X76
42	CM	55-57	CCUA LSR
43	MM	58	STATUS
44	CHM	59	Unused
45	Unused	60-61	CCUA CP abend
46-49	IA	62-63	CCUA TA
50-53	PSCI	64-85	Unused
54-57	OP	86	STATUS
58-105	Regs interrupt LVL	87	Unused
106-107	CHCV	88-89	CCUA CP abend
108-109	Register space	90-91	CCUA TA
110-113	Main storage loc.	92-103	MCAD REGS
114-117	CHIO (current)	104	Map of register value
118-119	DUMP	105	CCU for CADs
120	MOSS dump stat	106	IOC for CADs
121	EIRV (1)	107	NUM for CADs
122	IORV (1)	108-113	Reentry count
123	PIRV (1)	114-120	Count for unexpected interrupt
124-125	DIV (1)	121	CHGH1CAC return code
130-133	PSCI (1)	122	Unused
134-137	OP (1)		
138-142	PCA1		
143-147	PCA2		
148-152	PCA3		
153	Unused		
154-165	MCCUA		
166-177	Unused		
178-181	Unused		
182-193	MCAD		
194-196	DFA		
197	TOD		
198-224	Snapshot dump		
225-232	Module name		
233-251	Spurious error cnt		
252-289	Statistics count		

NOTE: The fields followed by (1) give information in case of a level 0 re-entry.

Figure 11-16 (Part 1 of 11). MOSS BER Type 01 Formats

Format: foM2

ID: 02	
Byte	Meaning
1-27	Header
28-29	TYPE-ID
30	MOSS-CHECK
31	ADNO
32	CMD
33	PIRV
34	IOIRV
35	CMSB
36	STAC
37	CAC-RC
38	CA
39-40	STAT0
44-45	STAT1
46-47	STAT4
48-49	Unused
50-53	ADDR
54-65	PCW
66	Flags (ACB)

Format: foM3

ID: 03	
Byte	Meaning
1-27	Header
28-29	TYPE-ID
30	MOSS-CHECK
31	DEV
32	CMD (log. cmd)
33	REQ
34	Flag
35	CNT
36	Unused
37	ARC
38-41	ADDR
42-43	BSTAT
44-49	CCB
50-57	BCLE
58-69	SSB
70-77	FILE mod name

Format: foM2b

ID: 02	
Byte	Meaning
1-27	Header
28-29	TYPE-ID
30	MOSS-CHECK
31	CMD
32-47	NCP MB REQUEST
48-63	NCP MB RESPONSE

Format: foM4

ID: 04

Byte	Meaning
1-27	Header
28-29	TYPE-ID
30	MOSS-CHECK
31	CMD
32	BSTAT
33	ASTAT
34-35	CSTAT
36	MSTAT

Format: foM5

ID: 05

MOSS Check 00 01 02 04 05 08 10 20 40 80 FF	
Byte	Meaning
1-27	Header
28-29	TYPE-ID
30	MOSS-CHECK
31	ADDR
32-34	X76
35-36	STATUS
37	Adapter ID
38	IOC bus IS

Figure 11-16 (Part 2 of 11). MOSS BER Type 01 Formats

MOSS BER Formats

Format: foM5a	
ID: 05	
MOSS Check F0	
Byte	Meaning
1-27	Header
28-29	TYPE-ID
30	MOSS-CHECK: F0
31	ADDR
32-33	DUMP info
34	Unused
35-58	Scanner dump

Format: foM7	
ID: 06	
MOSS Check 01 02	
Byte	Meaning
1-27	Header
28-29	TYPE-ID
30	MOSS-CHECK

Format: foM7a	
ID: 06	
MOSS Check 04	
Byte	Meaning
1-27	Header
28-29	TYPE-ID
30	MOSS-CHECK
31	LA address

Format: foM6	
ID: 06	
MOSS Check 03 06	
Byte	Meaning
1-27	Header
28-29	TYPE-ID
30	MOSS-CHECK
31	IPL information
32	CCU Id
33	REQ
34	LVL1 REQ
35	System status
36-37	IPL check code
38-165	LA
166-180	Disk error
181-182	F2
183-185	X71
186-188	X72
189	IPL mode
190-192	CCU configuration
193-216	MIS (Error 06)
217	F1
218-219	RC from CDF
220-315	CA
316-317	IPLCHECK
318	Unused
319	3746-900

Format: foM8	
IDs: 91 B3 C1 C2	
Byte	Meaning
1-27	Header
28-29	TYPE-ID
30	MOSS-CHECK
31-32	COMMAND
33-64	MB

Figure 11-16 (Part 3 of 11). MOSS BER Type 01 Formats

Format: foM9	
ID: 06	
EXT: 05 07 MOSS Check 05	
Byte	Meaning
1-27	Header
28-29	TYPE-ID
30	MOSS-CHECK: 05
31	EXTENSION: 05/07
32	CCU Id
33-34	NCP abend
35	Dump status 0
36	Unused

Format: foM9a	
ID: 06	
EXT: 05 MOSS Check 08	
Byte	Meaning
1-27	Header
28-29	TYPE-ID
30	MOSS-CHECK: 08
31	EXTENSION: 05
32	CCU Id
33-35	IAR
36-38	SAR
39-41	LAR
42-44	X70
45-47	X76
48-50	X7D
51-53	X7E
54-55	HDCK

Format: foM10	
ID: 06	
MOSS Check 09	
Byte	Meaning
1-27	Header
28-29	TYPE-ID
30	MOSS-CHECK: 09
31	CCU
32-33	IPL-CHECK(0F1B)
34-36	X71 MSA displ.
37-39	X72 MSA displ.
40-42	IAR
43-45	WKR1
46-48	WKR2
49-51	WKR3
52-54	WKR4
55-57	WKR5
58-60	WKR6
61-63	WKR7
64-65	X7E
66-67	X7D
68-69	X76
70-71	CA XD
72-73	CA XE
74-75	X50
76-77	X51
78-79	X52
80-81	X60
82-145	LA

Format: foM12	
ID: 19	
Byte	Meaning
1-27	Header
28-29	TYPE-ID
30	Flag (error C)
31-32	Alert indicator
33	Req
34	FCN
35	Serv
	Panel old:
36	Req
37	FCN
38	Serv
39-86	Hexadecimal codes
87-88	CDF RC
89-90	ECB DISC
	MIOC:
91-92	CCUA
93-94	CCUB
	MB CCUA:
95	CMND
96-97	STAT
	MB CCUB:
98	CMND
99-100	STAT

Figure 11-16 (Part 4 of 11). MOSS BER Type 01 Formats

MOSS BER Formats

Format: foM14	
IDs: 10 11	
Byte	Meaning
1-27	Header
28-29	TYPE-ID
30-37	OC1
38-45	OC2 common
46-53	CCUF
54-61	CCUB
62-107	IORB
108-115	PLIST for ID 10
108-127	PLIST for ID 11

Format: foM15	
IDs: 12 13 14	
Byte	Meaning
1-27	Header
28-29	TYPE-ID
30-37	OC1
38-45	OC2
46-53	CCUF
54-61	CCUB
62-77	IORB for ID 14
62-90	IORB for ID 13
62-107	IORB for ID 12

Format: foM16	
ID: 08	
Byte	Meaning
1-27	Header
28-29	TYPE-ID
30	DUMP
31	TRACE
32	CA
33	CCU
34	Unused

Format: foM18	
IDs: 16 1A 1B 1D	
Byte	Meaning
1-27	Header
28-29	TYPE-ID
30-37	OC1
38-45	OC2
46-53	CCUF
54-61	CCUB
62-77	IORB
82-93	PLIST

Format: foM19	
ID: 06	
MOSS Check: 08 EXT: 07	
Byte	Meaning
1-27	Header
28-29	TYPE-ID
30	MOSS-CHECK
31	EXT
32	CCU
33-34	CP abend code

Format: foM21	
ID: 20	
Byte	Meaning
1-27	Header
28-29	TYPE-ID
30	MOSS-check
31	ORIGI
32	Function
33	SERV
34	CCU
35	STATUS
36	REQ
37	LVL1-REQ
38	Configuration
39	CCU Default
40	3745 mode

Figure 11-16 (Part 5 of 11). MOSS BER Type 01 Formats

Format: foM22	
ID: 85	
Byte	Meaning
1-27	Header
28-29	TYPE-ID
29-xx	1st BER with its own length
xxx-xxx	2nd BER with its own length
xxx-xxx	3rd BER with its own length
Note: There may be more than three BERs	

Format: foM23	
ID: 21	
EXT: 01 02 03 04 05	
Byte	Meaning
1-27	Header
28-29	TYPE-ID
30	Event-ext
31	Status
32	CCU ID
33	Configuration
34	CAC return code
35	CCU default
35	3745 mode

Format: foM24	
IDs: 24 to 29, 37	
Byte	Meaning
1-27	Header
28-29	TYPE-ID
30	CA

Format: foM25	
ID: 30	
Byte	Meaning
1-27	Header
28-29	TYPE-ID
30-31	FRU GROUP

Format: foM27	
ID: 32	
Byte	Meaning
1-27	Header
28-29	TYPE-ID
30-33	PLIST
34-37	PRB
39	DATA
40-41	CMND
42-43	ERR

Format: foM27a	
ID: 0A	
Byte	Meaning
1-27	Header
28-29	TYPE-ID
30	Error code (FF)
31	Error extension
32	ELA number
33	ELA error status
34	CCU (01)

Figure 11-16 (Part 6 of 11). MOSS BER Type 01 Formats

MOSS BER Formats

Format: foM29	
ID: 07	
ERROR: 04 08 40 80	
Byte	Meaning
1-27	Header
28-29	TYPE-ID
30	ERROR
31-32	TRA ADDR
33-34	Get CMD complete Lvl 2 err status
35-36	TIC 1 Lvl 2 error status
37-38	TIC 2
39-42	Unused
43-44	MOSS error status
45-46	Lvl 1 error status
47-48	TIC CTL register
49-51	X'76'

Format: foM29a	
ID: 07	
ERROR: FE	
Byte	Meaning
1-27	Header
28-29	TYPE-ID
30	ERROR= FE
31-32	TRA INPUT ADDR
33-34	TRA OUTPUT ADDR
35	TIC NBR
36-37	2K-blk INITIAL
38-39	2K-blk REQUEST
40-41	2K-blk FINAL
42	STOP CMD CNT

Format: foM29b	
ID: 07	
EXT: 01 02 03 04 05	
Byte	Meaning
1-27	Header
28-29	TYPE-ID
30	ERROR
31	ERROR EXT
32	TRA number
33-34	TRA address
35	TIC number
36	CCU

Format: foM30	
ID: 15	
Byte	Meaning
1-27	Header
28-29	TYPE-ID
30-37	OC1
38-45	OC2
46-53	CCUF
54-61	CCUB
62-77	IORB
78-101	PLIST
102-133	BLK4T

Figure 11-16 (Part 7 of 11). MOSS BER Type 01 Formats

Format: foM31		Format: foM33	
ID: 17		ID: 39	
Byte	Meaning	Byte	Meaning
1-27	Header	1-27	Header
28-29	TYPE-ID	28-29	TYPE-ID
30	MOSS-CHECK	30	IORV
31	BCLE	31	PIRV
32	CMD	32-233	Internal buffer
33	B STAT	234	Status
34	A STAT	235	REQ
35-38	C STAT		
39	M STAT		
Format: foM34		Format: foM35	
ID: 06		ID: 06	
MOSS Check 13		MOSS Check 14	
Byte	Meaning	Byte	Meaning
1-27	Header	1-27	Header
28-29	TYPE-ID	28-29	TYPE-ID
30	MOSS-CHECK	30	MOSS-CHECK
31	CCU	31	CCU
32-35	LOAD MODULE name	32-35	LOAD MODULE name
36-40	TIMED IPL DATE/TIME	36-40	TIMED IPL DATE/TIME
41-45	REFERENCE DATE/TIME	41-45	REFERENCE DATE/TIME
		46	MOSS CANCEL ORIGIN

Figure 11-16 (Part 8 of 11). MOSS BER Type 01 Formats

MOSS BER Formats

Format: foM36

ID: 1E	
Byte	Meaning
1-27	Header
28-29	TYPE-ID
30-37	IOC1
38-45	IOC2
46-53	CCUF
54-61	CCUB
62-85	IORB

Format: foM37

ID: 23	
Byte	Meaning
1-27	Header
28-29	TYPE-ID
30	CCU
31	PS 3746-900 error

Format: foM38

ID: 2A	
Byte	Meaning
1-27	Header
28-29	TYPE-ID
30	TA
31	TD
32	CCU
33-36	SLID

Format: foM39

ID: 2B	
Byte	Meaning
1-27	Header
28-29	TYPE-ID
30	TA
31	TD
32	CCU
33	Origin

Format: foM40

ID: A0	
Byte	Meaning
1-27	Header
28-29	TYPE-ID
30-31	Error code
32-34	Panel code
35-37	IML request
38	MOSS/MOSS-E model
39-42	DIAG status

Format: fo41

ID: A1	
Byte	Meaning
1-27	Header
28-29	TYPE-ID
30	Reason
31-33	Panel code

Format: foM42

ID: A2	
Byte	Meaning
1-27	Header
28-29	TYPE-ID
30-32	Old panel code

Figure 11-16 (Part 9 of 11). MOSS BER Type 01 Formats

Format: foM43

ID: A3	
Byte	Meaning
1-27	Header
28-29	TYPE-ID
30	MOSS check
31-34	SLID
35-38	Transaction ID
39	LAN status
40	FRB type in error
41	MOSS check cause
42-50	Previous req. summa
51-54	SSA Cmd header
55-62	Server name
63-66	Current Inst. Addr.
67-137	Received message

Format: foM45

ID: 2C	
Byte	Meaning
1-27	Header
28-29	TYPE-ID
30-31	Completion code
32-35	CPN
36	CCU ID
37-60	Reference code

Format: foM46

ID: 2D	
Byte	Meaning
1-27	Header
28-29	TYPE-ID
30-31	CCU ID
32	REASON

Format: foM47

ID: 06 MOSS Check: 18	
Byte	Meaning
1-27	Header
28-29	TYPE-ID
30-221	LSSD string first part

Format: foM44

ID: A4	
Byte	Meaning
1-27	Header
28-29	TYPE-ID
30	MOSS check value
31	Reason code
32	Major request code
33	Minor request code
34	Major return code
35	Minor return code
36	Global LAN status
37	LAN manager status
38-39	Open error code
40-41	Ring status
42-43	Link status
44-47	Current Inst. Addr.
48-53	Local adap MAC addr DLC counters
54-55	Transmit counter
56-57	Receive counter
58	Transmit error
59	Receive error
60-61	T1 expired
62	Received command
63	Sent command
64	Primary state
65	Secondary state
66	Station VS
67	Station VR
68	Station VA
	MAC counters
69	Line error
70	Internal error
71	Burst errors
72	ARI/FCI error
73	Abort delimiter
74	Unused
75	Lost frame
76	Receive congestion
77	Frame copied error
78	Frequency error
79	Token error
80-82	Unused

Format: foM48

ID: 06 MOSS Check: 28	
Byte	Meaning
1-27	Header
28-29	TYPE-ID
30-346	LSSD string second part

Figure 11-16 (Part 10 of 11). MOSS BER Type 01 Formats

MOSS BER Formats

Format: foM50	
ID: A3	
Byte	Meaning
1-27	Header
28-29	TYPE-ID
30	IML origine
31-32	Low address
33-34	High address
35	Adapter address

Figure 11-16 (Part 11 of 11). MOSS BER Type 01 Formats

Diagnostics BER Type 03

Diagnostics BER Type 03 - Summary

<i>Table 11-47. BER Type 03 Description</i>	
BER ERROR	ID DESCRIPTION
01	Diagnostic started
02	Diagnostic completed successfully
03	Hardware error detected by diagnostic
04	Microcode error detected in a diagnostic (ABEND type 1 and 2)
05	Microcode error detected in the monitor (ABEND type 3)

Diagnostics BER Type 03 - Detailed BER Display

Diagnostics BER Type 03 - IDs 01 and 02: Format foD1, see page 11-124

```

                                ELD DETAIL
SEL#:hhhh FLAG:hh DATE:dd/dd TIME:dd:dd TYPE:03 ID:hh
<ERROR DESCRIPTION>                <REFER.CODE IN CHAR.> CCCCCCCC
GROUP NBR:hh  IFT/SECT:hhhh  ROUTINE:hh  ADT NBR:hh  LINE NBR:hh

====>

F1:END F2:MENU2 F3:ALARM F4:SUMMARY F5:LIST F7:PREVIOUS F8:NEXT

```

Diagnostics BER Type 03 - ID 03: Format foD2, see page 11-124

```

                                ELD DETAIL
SEL#:hhhh FLAG:hh DATE:dd/dd TIME:dd:dd TYPE:03 ID:03
<ERROR DESCRIPTION>                <REFER.CODE IN CHAR.> CCCCCCCC
ERC:hhhh  RAC:hhhh
ERROR BIT:hhhh
ADT NBR:hh  LINE NBR:hh  MUX NBR:hh  CCU ATT:hh
IFT/SECT:hhhh  ROUTINE:hh

====>

F1:END F2:MENU2 F3:ALARM F4:SUMMARY F5:LIST F7:PREVIOUS F8:NEXT

```

Diagnostics BER Type 03 - IDs 04 and 05: Format foD3, see page 11-124

```

                                ELD DETAIL
SEL#:hhhh FLAG:hh DATE:dd/dd TIME:dd:dd TYPE:03 ID:hh
<ERROR DESCRIPTION>                <REFER.CODE IN CHAR.> CCCCCCCC
RAC:hhhh  ADT NBR:hh  CCU ATT:hh  IFT/SECT:hh  ROUTINE:hh

====>

F1:END F2:MENU2 F3:ALARM F4:SUMMARY F5:LIST F7:PREVIOUS F8:NEXT

```

Note: When running the diagnostics, the BR option generates the diagnostic BERs when a machine error is encountered. To suppress the generation, the command 'NBR' is used. The default option is BR. For more information see *Service Functions, SY33-2069*.

Diagnostic BERs Type 03 - Formats

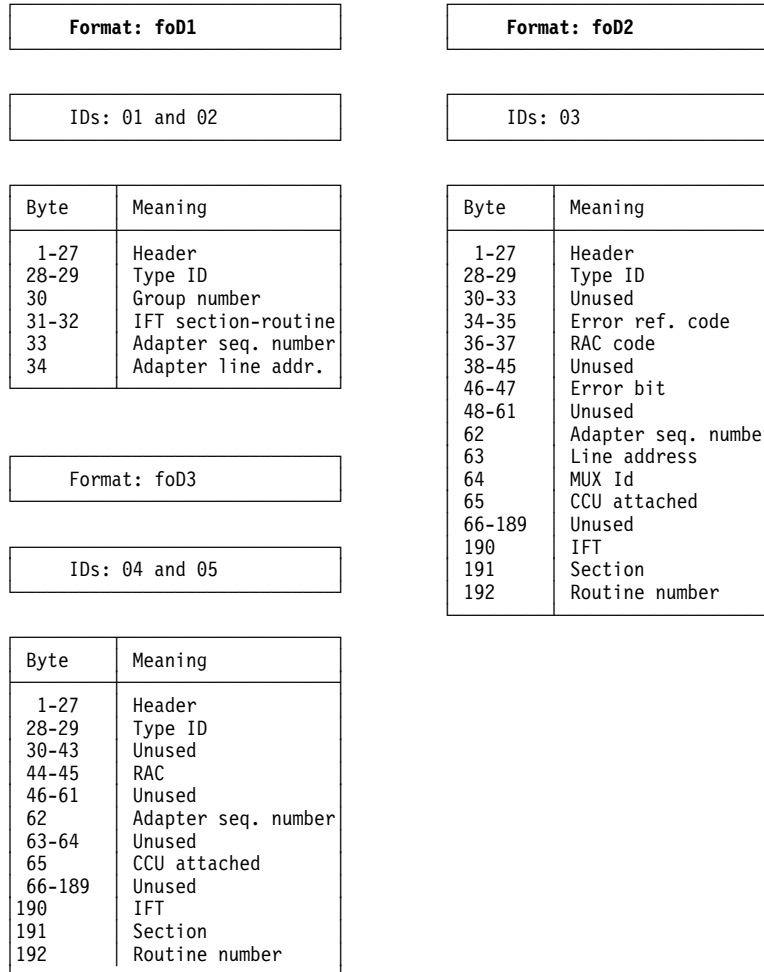

Figure 11-17. Diagnostics BER Formats

Power BER Type 04

Power Subsystem BER Type 04 - Summary

BER ID	Description of the event	ALERT	ALARM
01	Overcurrent fault	--	9C
02	PS fault	--	9C
04	Airflow fault	--	A7
08	MOSS control panel error	08	08
0A	Power control mode change	--	--
0F	Battery failure	A5	A5
10	Internal clock down	A6	A6
11	Thermal detector failure	--	9B
12	AC failure	A3	A3
13	Invalid AC failure	A4	A4
14	Cooling problem corrected	AD	AD
15	Remote power OFF received	--	--
17	Battery OK. Perform a POS and a MOSS IML	A9	A9
20	Error on MOSS reset	AC	AC
21	Error on MMIO	AC	AC
22	Error on RPO signal	AC	AC
23	Error on CCU reset	--	AC
28	End of IML data due to a temporary AC failure	A3	A3
29	End of IML data due to an unexpected event	--	--
30	Microcode error/Power dump	AB	AB
31	Set time of day	--	--
35	Battery changed. Perform a POS and a MOSS IML	NO	A9
36	Change battery	A5	A5

Figure 11-18. Power Subsystem BER Type 04 Summary

Note: The description of the events does not necessarily match the alarm messages listed in the *Problem Determination Guide*.

Power BER Type 04 (Detailed BER Display)

Power BER Type 04 - IDs 01, 02, 04, 08 and 12: Format foP1, see page 11-132.

```

                                ELD DETAIL
SEL#:hhhh FLAG:hh DATE:dd/dd TIME:dd:dd TYPE:04 ID:hh
<ERROR DESCRIPTION>                <REFER.CODE IN CHAR.> CCCCCCCC
REQ:hh  RESP:hh  PS ID:hh  AFD ID:hh
PS TYPE:hh  OLD STATUS:bbbb  BUS ID:bbbbbbbb
ADAPTER1:hh  ADAPTER2:hh
RPO:hh  CCU:hh

====>

F1:END F2:MENU2 F3:ALARM F4:SUMMARY F5:LIST F7:PREVIOUS F8:NEXT

```

Power BER Type 04 - ID 0A: Format foP1, see page 11-132.

```

                                ELD DETAIL
SEL#:hhhh FLAG:hh DATE:dd/dd TIME:dd:dd TYPE:04 ID:0A
<ERROR DESCRIPTION>                <REFER.CODE IN CHAR.> CCCCCCCC
OLD      NEW
bbbbbbbb bbbbbbbb

===>

F1:END F2:MENU2 F3:ALARM F4:SUMMARY F5:LIST F7:PREVIOUS F8:NEXT

```

Power BER Type 04 - IDs 17, 35 and 36: Format foP5, see page 11-132.

```

                                ELD DETAIL
SEL#:hhhh FLAG:hh DATE:dd/dd TIME:dd:dd TYPE:04 ID:0A
<ERROR DESCRIPTION>                <REFER.CODE IN CHAR.> CCCCCCCC

===>

F1:END F2:MENU2 F3:ALARM F4:SUMMARY F5:LIST F7:PREVIOUS F8:NEXT

```

Power BER Type 04 - IDs 20 to 23: These BER display a single line of information, indicating the type of error, according to the next list:

- ID 20** Power control detected error on MOSS reset
- ID 21** Power control detected error on MMIO
- ID 22** Power control detected error on RPO signal
- ID 23** Power control detected error on CCU reset

One of those BER is generated when the corresponding lines is found every time clamped to the same level.

Power BER Type 04 - IDs 28, 29: Format foP2, see page 11-132.

```

                                ELD DETAIL
SEL#:hhhh FLAG:hh DATE:dd/dd TIME:dd:dd TYPE:04 ID:hh
<ERROR DESCRIPTION>                <REFER.CODE IN CHAR.> CCCCCCCC
IML SOURCE:hh CAUSE:hh REASON:hh
CONTROL MODE:hh INSTAL TYPE:hh

===>

F1:END F2:MENU2 F3:ALARM F4:SUMMARY F5:LIST F7:PREVIOUS F8:NEXT

```

Power BER Type 04 - ID 30: Format foP3, see page 11-132.

```

                                ELD DETAIL
SEL#:hhhh FLAG:hh DATE:dd/dd TIME:dd:dd TYPE:04 ID:30
<ERROR DESCRIPTION>                                <REFER.CODE IN CHAR.> CCCCCCCC

IOIRV:hh PIRV:hh REQ:hh RESP:hh
ERR:hh ECB:hhhh

====>

F1:END F2:MENU2 F3:ALARM F4:SUMMARY F5:LIST F7:PREVIOUS F8:NEXT
    
```

Power BER Type 04 - ID 31: Format foP4, see page 11-132.

```

                                ELD DETAIL
SEL#:hhhh FLAG:hh DATE:dd/dd TIME:dd:dd TYPE:04 ID:31
<ERROR DESCRIPTION>                                <REFER.CODE IN CHAR.> CCCCCCCC
DATE:hh / hh / hh
DAY :hh
TIME:hh : hh : hh

====>

F1:END F2:MENU2 F3:ALARM F4:SUMMARY F5:LIST F7:PREVIOUS F8:NEXT
    
```

Power BER Type 04 - Field Description

Table 11-48. Power BER type 04 Field Description		
Field name	Meaning	Refer to
AFD	Not used	--
BUS ID	Not used	--
CCU	Value is 00, except in case of case of RPO: hh = 01 for CCUA	--
Control Mode	See OLD and NEW	Page 11-128
ECB	Event control block	(*)
ERR	Microcode error	Page 11-128
IML/IPL	<ul style="list-style-type: none"> • Source of IML/IPL • Cause of IML/IPL • Reason of power OFF 	<ul style="list-style-type: none"> • Page 11-128 • Page 11-128 • Page 11-128
Install-Type	MPW power logic card state	Page 11-128
IOIRV	I/O interrupt request vector	Page 11-44
LAR	Lagging address registers (input X'74')	
NEW	New panel info (01=host, 02=network, 03=local)	--
OLD	Old panel info (01=host, 02=network, 03=local)	--
PIRV	Program interrupt request vector	Page 11-44
PS ID	Not used	--
PS Type	Not used	--
REQ	See request description	Page 11-129
RESP	PLC response to MOSS	Page 11-131
RPO	Request power OFF	Page 11-128

(*) For software information on BERs originated by NCP/PEP, refer to the associated product documentation.

Power BER Type 04 - Field Details

Some of the following fields may not appear on the ELD detail display, but they are part of the BER and they are listed as they appear in the BER file. See the section 'BER Formats on Disk' page 11-112

Field Name	Field Value	Meaning
IPL/IML source	01	Host requested IPL
	02	Auto restart
	03	Unused
	04	Request from panel
	05	Unused
	06	Scheduled power ON
	07	Unused
IPL/IML cause	01	MOSS IML
	02	General IPL
	03	Unused
	04	MOSS check
Microcode error	01	Invalid response
	02	Request expected
	03	Response expected
	04	Invalid interrupt
	05	Invalid asynchronous event
	06	Not used
	07	Power dump requested
REASON	01	Last power OFF reason Power OFF from host in host mode (power hold signal inactive) AC failure
	02	Remote power OFF in network mode
	03	Power OFF from panel in local mode
	04	Power OFF from EPO switch
	05	Air flow detector failure
	06	Overcurrent problem on a power block
	07	Power supply problem on a power block
	08	MOSS power ON reset line clamped every time at the same level
	09	
	1A	
RPO	01	General power OFF
	02	Remote power OFF request
	03	Requested power OFF failed
Install Type	00	Normal state
	01	First installation
	02 - 03	Unused
PS OLD/NEW status		Unused

RESP and REQ Fields

The **REQ** field may take a different meaning for identical values, depending on the event that was the cause of the BER:

- **BER caused by a power dump.**

The **RESP** field is always Dx:

- D1** The dump was possible.
D2 The dump already existed.
D3 The dump failed.

The **REQ** values are given in the following table.

Table 11-50. BER 04 REQ/RESP Table for Power Dump

REQ	Requested by	Meaning
01	PCC	Invalid power ON
02	PCC	Invalid power OFF
03	PCC	Invalid power ON reset
04	PCC	Invalid interrupt level 0
05	PCC	Invalid interrupt level 1
06	PCC	Invalid interrupt level 2
81	PCC	Invalid power ON, dump stacked
82	PCC	Invalid power OFF, dump stacked
83	PCC	Invalid power ON reset, dump stacked
84	PCC	Invalid interrupt level 0, dump stacked
85	PCC	Invalid interrupt level 1, dump stacked
86	PCC	Invalid interrupt level 2, dump stacked
11	MOSS	Power microcode error
12	MOSS	PCC ckeck bad return
20	Operator	Manual request, via power services

- **BER caused by an event in the power area.**

RESP field meaning depends on the associated **REQ** field value.

A REQ value corresponds to 2 possible RESP:

- OK response
- KO response

according to the following table:

Note: The **REQUEST** code is valid only when the BER is issued after a MOSS request to the power control.

Table 11-51 (Page 1 of 2). BER 04 REQ/RESP Table

REQ	RESP OK	RESP KO	Meaning
01	42	C2	Start diskette
02	43	C3	Stop diskette
05	N/A	N/A	MPWL reset
07	48	C8	Start disk
08	49	C9	Stop disk
09	4A	CA	Set adapter
0A	4B	CB	Reset adapter
0C	4E	N/A	Check MPWL
0D	50	N/A	Get end of IML data
0E	51	N/A	Get stacked error record
12	55	N/A	Set time of day
13	56	D6	Get time of day
14	57	N/A	Set scheduled power ON
15	58	N/A	Get scheduled power ON
16	59	N/A	Allow scheduling
17	5A	N/A	Inhibit scheduling
1B	5E	N/A	Get scheduling state
1F	70	F0	Display message indicator on panel
20	76	F6	Display console in use
21	7E	FE	Display hexadecimal code on panel

POWER BER

<i>Table 11-51 (Page 2 of 2). BER 04 REQ/RESP Table</i>			
REQ	RESP OK	RESP KO	Meaning
22	7F	FF	Display function code

If the BER is issued from an error reported to the MOSS by the power control:

- The **REQUEST** field is set to 00.
- The **RESP** field takes the meaning given in the following table:

Table 11-52. BER 04 RESP Table When REQ = 00

RESP	Meaning
00 to 05	Unused
06	Air flow fault
08	Overcurrent fault
09	PS fault
0D	Local request
0E	Force local
0F	Battery KO
11	Power control mode change
12	Panel KO
13	AC failure
14	Invalid AC failure
15	MPWA KO
16	Remote power OFF
18	Battery OK
19	Problem on CCU reset
1A	Problem detected on MOSS reset
1B	MMIO errors

Power BER Type 04 - Formats

Format foP1	
IDs: 01 02 04 08 12	
Byte	Meaning
1-27	Header
28-29	TYPE-ID
30	REQ
31	RESP
32	PS ID
33	AFD
34	Retry indicator
35	PS type
36	
bbbb	Old status
bbbb	Address
37	BUS ID
38	Adapter 1
39	Adapter 2
40	RPO
41	CCU
ID: 0A only	
42	Old control
43	New control
44	Tower ID for airflow fault

Format foP2	
IDs: 28 29	
Byte	Meaning
1-27	Header
28-29	TYPE-ID
30	IML source
31	CAUSE
32	POWER OFF reason
33	CTRL Mode
34-173	PCT
174-180	TOD
181	Install type
182-213	AFD status
214-217	Airflow fault on each tower

Format foP4	
ID: 31	
Byte	Meaning
1-27	Header
28-29	TYPE-ID
30-32	Time (SS, MM, HH) in Hex
33	Day of week
34-36	Date (day, month, year)

Format foP3	
ID: 30	
Byte	Meaning
1-27	Header
28-29	TYPE-ID
30	IORV
31	PIRV
32	REQ
33	RESP
34	ERR CODE
35-37	Unused
38-41	MPNL data
42-43	ECB

Format foP5	
IDs: 17 35 36	
Byte	Meaning
1-27	Header
28-29	TYPE-ID

Figure 11-19. Power BER Formats

NCP ESS BER Type 08

ESS BER Type 08 - Summary

<i>Table 11-53 (Page 1 of 4). ESS BER Type 08 Summary</i>					
BER ID	Abend Code (NCP)	Event Description	Recovery or Action	ALERT	ALARM
14	0930	ELAyy AIO Address Exception Check IOC error LVL1 with: LVL1 summary register X7E = '0100' (IOC-1) with IOC LVL1 register X76 = '8200' (IOC-1)	NCP re-IPL	No	E1
16	0931	ELAyy AIO Storage Protect Check IOC Error LVL1 with: LVL1 Summary Register X7E = '0100' (IOC-1) with IOC LVL1 Register X76 = '4200' (IOC-1)	NCP re-IPL	No	E1
18		ELAyy IOH/IOHI to Adapter not attached IOC Error LVL1 with: LVL1 Summary Register X7E = '0100' (IOC-1) with IOC LVL1 Register X76 = '2800' (IOC-1) For adapter address in TA, the CDS shows the adapter not attached.	None	30	30
1B	0933	ELAyy Invalid Input IOH IOC Error LVL1 with: LVL1 Summary Register X7E = '0100' (IOC-1) with IOC LVL1 Register X76 = '5800' (IOC-1) LAS (line adapter status) bit 1.7 is On.	NCP re-IPL	No	E1
1C		ELAyy Portx Command Rejected by Adapter Microcode Adapter LVL1 with: LVL1 Summary Register X7E = '2000' (IOC-1) with Adapter Status Register (Error Status Type 3 non-Hardstop) or LAS = B'1000 00u0 10xx xxxz' as command reject on line interface address = b'xxxxxz' where 'x..x' reflects the relative line address and 'z' gives the interface side (Xmit or Rcv). When 'u' = 1 this indicates a command reject for command-on-command.	Port down	31	31
1E		ELAyy Invalid Output IOH to Adapter Adapter LVL1 with: LVL1 Summary Register X7E = '2000' (IOC-1) with Adapter Status Register (Error Status Type 3 non-Hardstop) or LAS = B'1000 000u 0100 0000' as Invalid Output IOH for which the related PIO terminated correctly (no IOC error LVL1) but the adapter microcode rejects the Output IOH by raising this current adapter LVL1. 'u' = '1' means adapter disconnected due to NCP command 'F2'.	ELA down	32	32
26		ELAyy Portx SCTL/DMA Storage Protect or Address Exception Adapter LVL2 with: PSA LCS (Line Control Status) = 'DC' as any DMA type error PSA HELCS (High byte of Extended LCS) = '10' as specifically SP/AE	ELA port down	37	37

Table 11-53 (Page 2 of 4). ESS BER Type 08 Summary					
BER ID	Abend Code (NCP)	Event Description	Recovery or Action	ALERT	ALARM
91		ELAyy AIO Error IOC Error LVL1 with: LVL1 Summary Register X7E = '0100' (IOC-1) with IOC LVL1 Register X76 = 'uV00' (IOC-1) with AIO CCW Register X75H or X75L = B'1nnn n000' where nnnn from 0 to 15 represents the IOC relative adapter number, adapter which was performing the AIO, AIO (Adapter Initiated Operation / Cycle Steal) failing in Time-Out (V='A') or in Bus-In parity Check (V='6') with 'u' giving the time when the operation failed (refer to page 2-34).	ELA μ code retry	No	No
91		ELAyy AIO Error (threshold) Adapter Down flag is on.	ELA down	34	34
92		ELAyy Unresolved AIO Error IOC Error LVL1 with: LVL1 Summary Register X7E = '0100' (IOC-1) with IOC LVL1 Register X76 = 'uV00' (IOC-1) with AIO CCW Register X75H or X75L = B'1nnn n000' where nnnn from 0 to 15 represents the IOC relative adapter number, adapter which was performing the AIO, but as opposed to previous BER 08 91, V='2' only (not 'A' or '6').	ELA μ code retry	No	No
92		ELAyy Unresolved AIO Error (threshold) Adapter Down flag is On	ELA down	34	34
93		ELAyy AIO Invalid CSCW IOC Error LVL1 with: LVL1 Summary Register X7E = '0100' (IOC-1) with IOC LVL1 Register X76 = '2200' (IOC-1) AIO CCW register X75H or X75L = B'1nnn n000' where nnnn from 0 to 15 represents the IOC relative adapter number, adapter which was performing the AIO.	ELA μ code retry	No	No
93		ELAyy AIO Invalid CSCW (threshold) Adapter Down flag is On	ELA down	38	38
94		ELAyy Portx Cycle Steal Error on Set Mode Adapter LVL1 with: LVL1 Summary Register X7E = '2000' (IOC-1) Adapter Status Register (Error Status Type 3 non-Hardstop) or LAS = B'1000 0000 10xx xxxz' (almost identical to BER 08 1C as Command Reject on line interface address 'xxxxxz') but NCP looks at the SLI bit in the LNVT: if ON (Set LNVT Initial required) and if adapter command-reject status = '10xx xxxx xxxx xxxx' then NCP will generate this BER 08 94 instead of BER 08 1C.	Port down	3C	3C
95		ELAyy Adapter LVL1 Hardcheck Adapter LVL1 with: LVL1 Summary Register X7E = '2000' (IOC-1) with Adapter Status Register (Error Status Type 3 Hardstop) or LAS = B'0000 0uuu uuuu uu00' where the string 'uu..uu' reflects the hardware checkers which have been raised (u=1), as several can occur simultaneously in some cases of failure.	ELA down	34	34
96		ELAyy Adapter Disconnected by operator Adapter LVL1 with: LVL1 Summary Register X7E = '2000' (IOC-1) with Adapter Status Register (Error Status Type 3 non-Hardstop) or LAS = B'1000 0001 0000 0000', meaning "adapter put in disconnect mode" on MOSS operator's request.	ELA Off line	3D	3D

<i>Table 11-53 (Page 3 of 4). ESS BER Type 08 Summary</i>					
BER ID	Abend Code (NCP)	Event Description	Recovery or Action	ALERT	ALARM
97		ELAyy PIO Error IOC Error LVL1 with: LVL1 Summary Register X7E = '0100' (IOC-1) with IOC LVL1 Register X76 = 'uV00' (IOC-1) as PIO (Program Initiated Operation) failing in Time-Out (V='8') or in Bus-In parity Check (V='4') with 'u' giving the time when the operation failed (refer to page 2-34).	NCP retry	No	No
98		ELAyy PIO Error (threshold) IOC Error LVL1 with: Identical to BER 08 97 but on last IOH/PIO retry.	ELA down	34	34
99		ELAyy Adapter LVL1 non-Hardcheck Adapter LVL1 with: LVL1 Summary Register X7E = '2000' (IOC-1) with Adapter Status Reg- ister (Error Status Type 3 non-Hardstop) or LAS = B'1iii 0uu0 0000 000v' where 'iii' (invalid interrupt level from 0 to 7) and 'u' are checkers raised by Mcode and 'v' by hardware.	ELA down	32, 34, or 38	32, 34, or 38
9B		ELAyy LVL1 Interrupt from disconnected ELA	NCP retry	No	No
9B	093A	ELAyy LVL1 Interrupt from disconnected ELA (threshold)	NCP re-IPL	No	E3
9C		ELAyy PIO Error on Get Line ID (GLID) and PIO get error status (GES) to adapter shows LAS bit 1.0 On (TA time select).	NCP retry	No	No
9C		ELAyy PIO Error on GLID (threshold)	ELA down	34	34
9D		ELAyy Adapter Microcode detected error Adapter LVL1 with: LVL1 Summary Register X7E = '2000' (IOC-1) with Adapter Status Reg- ister (Error Status Type 3 non-Hardstop) or LAS = '8800' (Microcode Check). then NCP reads the adapter Mcode Check (TA1 = '31') which gives the CSECT and checker number. This last data overwrites the previous LAS contents which is then not seen in BER display.	ELA down	38	38
9E		ELAyy PIO Get Error Status failed IOC Error (X76 not 0) in LVL1 Identical to BER 08 97/98 but on IOH/PIO for Adapter Get Error Status either after an Adapter LVL1 or after an Adapter LVL2 leading to an IOH/PIO Get Line ID failure (IOC error LVL1).	ELA down	34	34
A1		ELAyy Portx Unexpected Interrupt LVL2 The BER is generated when Get Line ID data is invalid (not in the allowed range) or points on a line that is considered as not installed and therefore not SYSGENed in NCP, or points on a SYSGENed line but the line is not active from NCP view point.	NCP retry	No	No
A1	0936	ELAyy Portx Unexpected Interrupt LVL2 (threshold)	NCP re-IPL	No	E2
A2		ELAyy Portx Adapter Internal or Attachment Error Hardware error reported via LVL2 LCS = 'C0', 'C4', 'C6', 'C8', 'C9', 'CA', 'CE', 'D0', 'D6', 'D8', 'DA'.	Port down	3C	3C
A2		ELAyy Portx Adapter Internal or Attachment Error CP error reported via LVL2 LCS = 'D4', 'D2'.	Port down	31	31

Table 11-53 (Page 4 of 4). ESS BER Type 08 Summary

BER ID	Abend Code (NCP)	Event Description	Recovery or Action	ALERT	ALARM
A2		ELAyy Portx Adapter Internal or Attachment Error Environment error reported via LVL2 LCS = 'CB', 'DE', 'DF'.	Port down	3F	3F
A4		ELAyy Portx Time Out on command except F5	Port down	No	No
A6		ELAyy Portx SCTL/DMA internal Error Adapter LVL2 PSA LCS (Line Control Status) = 'DC' (SCTL/DMA/SWDM error) and PSA HELCS (High byte of extended LCS = '02', '12', '22').	Port down	3C	3C
A7		ELAyy Portx DMSW/SCTL DMA Interface error Adapter LVL2 PSA LCS (Line Control Status) = 'DC' (SCTL/DMA/SWDM error) and PSA HELCS (High byte of extended LCS = '04', '14', '24', '34', '44').	Port down	3C	3C
A8		ELAyy Portx DMSW DMA reported error Adapter LVL2 PSA LCS (Line Control Status) = 'DC' (SCTL/DMA/SWDM error) and PSA HELCS (High byte of extended LCS = '06', '16').	port down	3C	3C
A9		ELAyy Portx DMSW DMA Parity Check or Time Out Adapter LVL2 PSA LCS (Line Control Status) = 'DC' (SCTL/DMA/SWDM error) and PSA HELCS (High byte of extended LCS = '08', '18', '28').	Port down	3C	3C
AA		ELAyy Portx EAC DMA Interface Error Adapter LVL2 PSA LCS (Line Control Status) = 'DC' (SCTL/DMA/SWDM error) and PSA HELCS = '0A', '1A', '2A', '3A', '4A', '5A', '6A', '7A', '9A', 'AA', 'BA'.	Port down	3C	3C
B1		ELAyy Portx Time Out on command F5	Port down	3E	3E
B7		ESS link error not caused by controller hardware. BER information only.		No	No

Note: In case of abend, anNCP re-IPL is performed and an Alarm/Alert is generated when IPL is completed. This alert is triggered by MOSS BER 01 ID 06, error code 05.

ESS BER Type 08 - Detailed BER Display

ESS BER Type 08 - ID 14, 16, 91, 92, 93: Format foE1, see page 11-143.
 Program level 1 generates one of the following BERs when an error occurs during an AIO operation on a scanner.

```

                                ELD DETAIL
SEL#:hhhh  FLAG:hh DATE:dd/dd TIME:dd:dd TYPE:08 ID:hh<LOST:ddd CP-ABEND:hhhh>
<ERROR DESCRIPTION>                                <REF. CODE IN CHAR.> CCCCCCCC

F:bbbbbbbb
X7E:hhhh X76:hhhh X75:hhhh ETA:hhhh LAS:hhhh X76U:hhhh SPR:hhhhhhhh
SWA:hhhh LAR:hhhhhhhh

====>

F1:END F2:MENU2 F3:ALARM F4:SUMMARY F5:LIST F7:PREVIOUS F8:NEXT
    
```

ESS BER Type 08 - IDs 18, 1B, 97, 98, 9C, 9E: Format foE2, see page 11-143.
 Program level 1 generates one of these BERs when an error occurs during a PIO operation on a scanner.

```

                                ELD DETAIL
SEL#:hhhh  FLAG:hh DATE:dd/dd TIME:dd:dd TYPE:08 ID:hh<LOST:ddd CP-ABEND:hhhh>
<ERROR DESCRIPTION>                                <REF. CODE IN CHAR.> CCCCCCCC

F:bbbbbbbb X7E:hhhh X76:hhhh I:hhhh LAR:hhhhhhhh
LAS:hhhh X76U:hhhh ETA:hhhh SWA:hhhh IAR:hhhhhh TA:hhhh TD:hhhh
IOB/LXB:hhhhhhhh hhhhhhhh hhhhhhhh hhhhhhhh hhhhhhhh
            hhhhhhhh hhhhhhhh hhhhhhhh hhhhhhhh
CCB:hhhhhhhh hhhhhhhh hhhhhhhh hhhhhhhh hhhhhhhh hhhhhhhh hhhhhhhh hhhhhhhh
            hhhhhhhh hhhhhhhh hhhhhhhh hhhhhhhh hhhhhhhh hhhhhhhh hhhhhhhh
AXB:hhhhhhhh hhhhhhhh hhhhhhhh hhhhhhhh hhhhhhhh hhhhhhhh hhhhhhhh hhhhhhhh
SCB:hhhh hhhh hhhh hhhh hhhh hhhh hhhh hhhh hhh
PSA:hhhh hhhh hhhh hhhh hhhh hhhh hhhh hhhh hhhh hhhh hhhh hhhh hhhh hhhh

====>

F1:END F2:MENU2 F3:ALARM F4:SUMMARY F5:LIST F7:PREVIOUS F8:NEXT
    
```

ESS BER Type 08 - IDs 1E, 95, 96, 99, 9B, 9D: Format foE3, see page 11-143.
 Program level 1 generates one of these BERs when an error is reported by a scanner on level 1.

```

                                ELD DETAIL
SEL#:hhhh  FLAG:hh DATE:dd/dd TIME:dd:dd TYPE:08 ID:hh<LOST:ddd CP-ABEND:hhhh>
<ERROR DESCRIPTION>                                <REFER.CODE IN CHAR.> CCCCCCCC
F:bbbbbbbb
X7E:hhhh X76:hhhh ADNO:hh LAS:hhhh X76U:hhhh SWA:hhhh LAR:hhhhhhhh

====>

F1:END F2:MENU2 F3:ALARM F4:SUMMARY F5:LIST F7:PREVIOUS F8:NEXT
    
```

ESS BER Type 08 - ID A1: Format foE4, see page 11-144. These BERs are generated on a LVL2 unresolved interrupt.

```

                                ELD DETAIL
SEL#:hhhh  FLAG:hh DATE:dd/dd TIME:dd:dd TYPE:08 ID:hh<LOST:ddd CP-ABEND:hhhh>
<Error description>                                <REFER.CODE IN CHAR.> CCCCCCCC
F:bbbbbbbb
TA:hh TD:hh NW:hhhh IDR:hhhh LNVT:hhhhhhhh LCS:hh
PSA:hhhh hhhh hhhh hhhh hhhh hhhh hhhh hhhh hhhh hhhh hhhh hhhh hhhh hhhh
CNT:hhhh

OVERRIDE FLAG WITH NEW HEXADECIMAL VALUE
===>

F1:END F2:MENU2 F3:ALARM F4:SUMMARY F5:LIST F7:PREVIOUS F8:NEXT

```

ESS BER Type 08 - ID B1: Format foE5, see page 11-144. These BERs are generated on a LVL2 time out.

```

                                ELD DETAIL
SEL#:hhhh  FLAG:hh DATE:dd/dd TIME:dd:dd TYPE:08 ID:hh<LOST:ddd CP-ABEND:hhhh>
<Error description>                                <REFER.CODE IN CHAR.> CCCCCCCC
F:bbbbbbbb
TA:hh TD:hh NW:hhhh
PSA:hhhh hhhh hhhh hhhh hhhh hhhh hhhh hhhh hhhh hhhh hhhh hhhh hhhh
OVERRIDE FLAG WITH NEW HEXADECIMAL VALUE
===>

F1:END F2:MENU2 F3:ALARM F4:SUMMARY F5:LIST F7:PREVIOUS F8:NEXT

```

ESS BER Type 08 ID 26, A2, A3, A4, A5, A6, A7, A8, A9, AA: Format foE5, see page 11-144. Program level 2 generates one of these BERs when a scanner internal error or a transient line error is detected.

```

                                ELD DETAIL
SEL#:hhhh  FLAG:hh DATE:dd/dd TIME:dd:dd TYPE:08 ID:hh<LOST:ddd CP-ABEND:hhhh>
<ERROR DESCRIPTION>                                <REFER.CODE IN CHAR.> CCCCCCCC
F:bbbbbbbb TA:hh TD:hh NW:hhhh IDR:hhhh
PSA:hhhh hhhh hhhh hhhh hhhh hhhh hhhh hhhh hhhh hhhh hhhh hhhh hhhh
IOB/LXB:hhhhhhhh hhhhhhhh hhhhhhhh hhhhhhhh hhhhhhhh
          hhhhhhhh hhhhhhhh hhhhhhhh hhhhhhhh
CCB:hhhhhhhh hhhhhhhh hhhhhhhh hhhhhhhh hhhhhhhh hhhhhhhh hhhhhhhh hhhhhhhh
          hhhhhhhh hhhhhhhh hhhhhhhh hhhhhhhh hhhhhhhh hhhhhhhh hhhhhhhh
AXB:hhhh hhhh hhhh hhhh hhhh hhhh hhhh
SAT:hhhh hhhh hhhh hhhh hhhh hhhh hhhh hh
SCB:hhhh hhhh hhhh hhhh hhhh hhhh hhhh hh
CSC:hhhh CNT:hhhh

===>

F1:END F2:MENU2 F3:ALARM F4:SUMMARY F5:LIST F7:PREVIOUS F8:NEXT

```

Note: Lost and CP abend fields are displayed when applicable.

ESS BER Type 08 ID 94, 1C: Format foE6, see page 11-144. Program level 1 generates this BER when a command reject is reported by a scanner on level 1 (control program error).

```

                                ELD DETAIL
SEL#:hhhh  FLAG:hh DATE:dd/dd TIME:dd:dd TYPE:08 ID:hh<LOST:ddd CP-ABEND:hhhh>
<ERROR DESCRIPTION>                                <REFER.CODE IN CHAR.> CCCCCC
F:bbbbbbbb LNVT:hhhh PSA:hhhh hhhh hhhh hhhh hhhh hhhh hhhh hhhh
SCF:hh LSTAT:hh LAS:hhhh CR1:hh CR2:hh IAR:hhhhhhhh TA:hh TD:hh
IOB/LXB:hhhhhhhh hhhh hhhh hhhh hhhh hhhh hhhh hhhh hhhh
             hhhh hhhh hhhh hhhh hhhh hhhh
CCB:hhhhhhhh hhhh hhhh hhhh hhhh hhhh hhhh hhhh hhhh hhhh hhhh
             hhhh hhhh hhhh hhhh hhhh hhhh hhhh hhhh hhhh hhhh
AXB:hhhhhhhh hhhh hhhh hhhh hhhh hhhh hhhh hhhh hhhh hhhh hh
SCB:hhhh hhhh hhhh hhhh hhhh hhhh hhhh hhhh hhhh hh

===>

F1:END F2:MENU2 F3:ALARM F4:SUMMARY F5:LIST F7:PREVIOUS F8:NEXT

```

ESS BER Type 08 - ID B7: Format foE7, see page 11-144. Program level 3 generates the following BERs when an external ESS physical link error occurs.

```

                                ELD DETAIL
SEL#:hhhh  FLAG:hh DATE:dd/dd TIME:dd:dd TYPE:08 ID:hh<LOST:ddd CP-ABEND:hhhh>
<ERROR DESCRIPTION>                                CCCCCC
TA BYTE0:hh TD BYTE1:hh BFLAG:hhhh TDREFLECT:hhhh
XMTTOT:hhhh hhhh RCVTOT:hhhh hhhh XMTErr:hhhh hhhh RCVERR:hhhh hhhh
EXCSCLSN:hhhh hhhh LATECLSN:hhhh hhhh RVCNGST:hhhh hhhh CRCERR:hhhh hhhh
FRAMERR:hhhh hhhh RSIZERR:hhhh hhhh XMTDEF:hhhh hhhh ONECLSN:hhhh hhhh
MULTCLSN:hhhh hhhh

===>

F1:END F2:MENU2 F3:ALARM F4:SUMMARY F5:LIST F7:PREVIOUS F8:NEXT

```

BFLAG BER flag:

- 40 = RCVERR reached its threshold.
- 80 = XMTErr reached its threshold.

TDREFLECT Time Domain Reflectometry is a measure of the distance from a 3745 Ethernet adapter attachment to the point on the Ethernet where there is a fault that is causing signals to be reflected. The 3745 Ethernet adapter sees this condition as a cause of an Excess Collision Error. Whenever Excess Collision Errors Occur, a value will be stored for Time Domain Reflectometry. If no Excess Collision Errors have occurred during the interval for a counter report, this value will be zero. Unlike other counter values, this value only has 10 bits of valid data.

XMTTOT The Transmit Total Counter includes frames transmitted successfully and frames lost during transmission.

RCVTOT The Receive Total Counter includes frames received successfully and receive frames that were lost.

XMTErr The Transmit Error Counter includes all transmit frames lost. This count includes EXCSCLSN and LATECLSN.

RCVERR	The Receive Error Counter includes all receive frames that were lost. This count includes RVCNGST, CRCERR, FRAMERR, and RSIZERR.
EXCSCLSN	Excess Collision Errors occur when 16 attempts to transmit a frame fail because collisions are detected on the Ethernet.
LATECLSN	A Late Collision Error occurs when a transmit frame is lost because of a collision that takes place after the maximum time that should be required to detect a collision. In this case, the transmitter of the other frame should have been aware of the 3745 frame when it listened for the presence of carrier before beginning its transmission.
RVCNGST	A receive Congestion Error occurs when the 3745 adapter is unable to receive a frame because its buffers are filled.
CRCERR	A CRC Error occurs when a receive frame is discarded because a problem was detected with the cyclic redundancy check.
FRAMERR	A Framing Error occurs when a receive frame does not end on a byte boundary.
RSIZERR	A Receive Size Error occurs when a receive frame is longer than the Ethernet allowed maximum frame size of 1518 bytes.
XMTDEF	The Transmit Deferred Counter includes the number of frames for which the initial transmission of the frame was deferred because carrier was sensed on the Ethernet.
ONECLSN	The One Collision Counter includes the number of times that there was one collision before a frame was transmitted successfully.
MULTCLSN	The Multiple Collision Counter includes the number of times that there was more than one collision before a frame was transmitted successfully.

ESS BER Type 08 - ID B7 Triggering Condition

NCP will generate this BER when either:

1. The transmit error threshold (XMTERR) or
2. The receive error threshold (RCVERR) is reached.

XMTERR hits come from:

1. Excess collision errors (EXCSCLSN) or
2. Late collision errors (LATECLSN).

RCVERR hits come from:

1. Receive congestion errors (RVCNGST) or
2. CRC errors (CRCERR) or
3. Framing error (FRAMERR) or
4. Receive size error (RSIZERR).

ESS BER Type 08 - Field Description

Table 11-54 (Page 1 of 2). ESS BER Type 08 Field Description		
Field Name	Meaning	Refer to
ADNO LAS or L-STAT	ELA number (decimal) in error description field. Line adapter status reflecting: <ul style="list-style-type: none"> LA Error Status Type 1 (AIO error) LA Error Status Type 2 (PIO error) LA Error Status Type 3 (adapter LVL1) 	-
ETA IDR F SWA CR1 CR2 LAR SPR CSC	TA field of IOH failure in level 1. Get line ID response. Indicator flag (indicates a byte expansion follows) Switch adapter error register. First command sent to scanner Second command sent to scanner Lagging address register LA shared pointer register X'3F' or X'6F'. Configuration status control flag (contains X'FFFF' for PEP, BSC/SS and BNN lines).	- Chapter 4 (*) Unused page 2-42
CNT	Repetition count (BER flooding). Number of times the BER appeared.	
SCF I IAR LCS PORTnn	Secondary Control Field. First two bytes of instruction. IAR of interrupt level. Line communication status. Port number (1 or 2) within the ELA (in error description line).	page 12-30
LNVT LOST NW IOB/LXB	Line vector table. Lost record count (LRC). Network address (NCP) X'24' bytes of LXB (for SDLC lines) or IOB (for BSC/SS lines) control blocks. This area is padded with X'FF' for PEP.	- (*) (*) (*)
CCB	X'40' bytes of data from the CCB control block. <ul style="list-style-type: none"> If PEP, the fields are CCBL2 through CCBPOLL inclusive. If PEP, the fields are CCBTROPT through CCBXPTR inclusive. 	(*)
AXB ACB TRACE	X'E' bytes of data from the AXB control block from AXBFCTL through AXB+X'15' (ACB trace area). For PEP, this area contains the CCB extension starting at the PEP CCB + X'60'.	(*)
AXB PSA	X'11' bytes of data from the PSA trace area of the AXB control block (AXBASSCF through AXBTROFF). For PEP, this area contains the remaining portion of the CCB extension padded with X'F'.	(*)
SCB	X'19' bytes of the SCB/CUB from SCBSSCF (CUBSSCF) through SCBRTCNT (CUBRTCNT) inclusively. For BSC/SS lines and for PEP, this area is padded with X'FF's.	(*)
SAT	17 bytes of PSA trace area for NCP. For PEP, this area contains the EP CCB extension.	(*)
SCBCSCF PSA	Configuration station control flags (NCP only). Parameter area (16 bytes)-status area (12 bytes). The byte contents of the PSA depend on the current command (CCMD).	(* (*))
TA	IOH/IOHI image (TA: hh means TA data byte 0) (see CSn and PORTnn).	-
TD	IOH/IOHI image -- TD data adapter specific bytes (TD: hh means TD data byte 1).	-
X3F	CSP shared pointer register.	page 2-21

<i>Table 11-54 (Page 2 of 2). ESS BER Type 08 Field Description</i>		
Field Name	Meaning	Refer to
X74	X'74' - LAR bytes (See CSn and PORTnn).	page 2-26
X75	X'75' - Cycle steal control word register.	page 2-26
X76	X'76' - IOC error summary register.	page 2-26
X76U	X'76' - Cause of error not found (PIO to read error register failed).	page 2-26
X79	X'79' - Interrupt level.	page 2-26
X7E	X'7E' - CCU level 1 interrupt.	page 2-26
X7F	X'7F' - Interrupt request register CCU levels 2, 3, and 4	page 2-26

Note: All values are in hexadecimal notation (X'0' to X'F'), except for:

- Flag bytes F and CS STAT, which are in bit format (8 or 16 bits, 0 or 1)
- The error description line with a CS number and LINE number, which are in decimal notation.

(*) For software information on BERs originated by NCP/PEP, refer to the associated product documentation.

ESS BER Type 08 - Formats

Format: foE1	
ID: 14 16 91 92 93	
Byte	Meaning
1-27	Header
28-29	TYPE-ID
30	LOST
31-32	Abend
33-34	X7E
35-36	X76
37-38	X75
39-40	Unused
41-42	ETA
43-44	LAS
45-46	X76U
47-50	SPR
51	Flag
52	Unused
53-54	SWA
55-58	LAR

Format: foE2	
IDs: 18 1B 97 98 9C 9E	
Byte	Meaning
1-27	Header
28-29	TYPE-ID
30	LOST
31-32	Abend
33-34	X7E
35-36	X76
37-38	I
39-42	LAR
43-44	LAS
45-46	X76U
47-48	ETA
49-50	Unused
51	Flag
52	Unused
53-54	SWA
55	INTLVL
56-58	IAR
59-60	TA
61-62	TD
63-66	Unused
67-102	IOB/LXB
103-166	CCB
167-198	AXB
199-215	SCB
216	Unused
217-244	PSA

Format: foE3	
ID: 1E 95 96 99 9A 9B 9D	
Byte	Meaning
1-27	Header
28-29	TYPE-ID
30	LOST
31-32	Abend
33-34	X7E
35-36	X76
37	ADNO
38-42	Unused
43-44	LAS
45-46	X76U
47-50	Unused
51	F
52	TSS Flag
53-54	SWA
55-58	LAR
59-66	Unused
67-102	LBX
103-166	CCB
167-182	ATT
183-198	PSA Trace

Figure 11-20 (Part 1 of 2). ESS BER Formats

Format: foE4

ID: A1	
Byte	Meaning
1-27	Header
28-29	TYPE-ID
30	LOST
31-32	Abend
33	F
34	Unused
35-36	IDR
37-64	PSA (56 = LCS)
65	TA byte 0
66	TD byte 1
67-68	NW
69-72	LNVT
73-108	IOB/LXB
109-172	CCB
173-186	AXB trace
187-203	AXB trace
204-219	SCB
220	SCBCSCF
221-222	Count

Format: foE5

IDs: 26 A2 A3 A4 A5 A6 A7 A8 A9 AA AB B1	
Byte	Meaning
1-27	Header
28-29	TYPE-ID
30	LOST
31-32	Abend
33	Flag
34	Unused
35-36	IDR
37-64	PSA
65	TA byte 0
66	TD byte 1
67-68	NW
69-104	IOB/LXB
105-168	CCB
169-182	AXB (IOB)
183-199	SAT trace
200-215	SCB
216	CSC
217-218	Count (Only for A2, A4, and AB)

Format: foE6

ID: 94 1C	
Byte	Meaning
1-27	Header
28-29	TYPE-ID
30	LOST
31-32	Abend
33	F
34	Interrupt level 1
35-36	LNVT
37-52	PSA
53	SCF
54	LSTAT
55-56	LAS
57	CR1
58	CR2
59-62	IAR
63-64	Unused
65	TA
66	TD
67-102	LXB/IOB
103-166	CCB
167-197	AXB
198	Unused
199-215	SCB
216	Unused

Format: foE7

ID: B7	
Byte	Meaning
1-27	Header
28-29	TYPE-ID
30	LOST
31-32	Abend
33	TA Byte 0
34	TD Byte 1
35-36	BFLAG
37-38	TDREFLECT
39-42	XMTTOT
43-46	RCVTOT
47-50	XMTERR
51-54	RCVERR
55-58	EXCSCLSN
59-62	LATECLSN
63-66	RCVNGST
67-70	CRCERR
71-74	FRAMERR
75-78	RSIZERR
79-82	XMTDEF
83-86	ONECLSN
87-90	MULTCLSN

Figure 11-20 (Part 2 of 2). ESS BER Formats

NCP 3746 Model 900 BER Type 9

3746 Model 900 BER Type 9 - Summary

<i>Table 11-55 (Page 1 of 4). 3746 Model 900 BER Type 9 Summary</i>					
BER ID	Abend Code (NCP)	Event Description	Recovery or PGM Action	MOSS ALERT	ALARM
10		Cmd Reject-No prior Set vvvv vvvv stands for LNVt, ALNVt, or TLNVt X7E='2000' (IOC-1 with CBA-1) or '0200' (IOC-2 with CBA-2) CBA LVL1 with first GES = X'2802', second GES = IOH TA, third GES = IOH TD	CSS Adapter down	EC	EC
11		Cmd Reject-Set vvvv Out of Sequence vvvv stands for LNVt, ALNVt, or TLNVt X7E='2000' (IOC-1 with CBA-1) or '0200' (IOC-2 with CBA-2) CBA LVL1 with first GES = X'2902', second GES = IOH TA, third GES = IOH TD	CSS Adapter down	EC	EC
12		Cmd Reject-Set CDF/E Out of Sequence X7E='2000' (IOC-1 with CBA-1) or '0200' (IOC-2 with CBA-2) CBA LVL1 with first GES = X'2A02', second GES = IOH TA, third GES = IOH TD	CBA down	E4	E4
13		Cmd Reject-Invalid Adapter Address X7E='2000' (IOC-1 with CBA-1) or '0200' (IOC-2 with CBA-2) CBA LVL1 with first GES = X'2302', second GES = IOH TA, third GES = IOH TD	None	EB	EB
14		Cmd Reject-Invalid Line Address X7E='2000' (IOC-1 with CBA-1) or '0200' (IOC-2 with CBA-2) CBA LVL1 with first GES = X'2402', second GES = IOH TA, third GES = IOH TD	None	F1	F1
15		Cmd Reject-No prior Start Line Initial X7E='2000' (IOC-1 with CBA-1) or '0200' (IOC-2 with CBA-2) CBA LVL1 with first GES = X'2502', second GES = IOH TA, third GES = IOH TD	Line down	No but NCP alert	F2
16		Cmd Reject-Xmit Command on Command X7E='2000' (IOC-1 with CBA-1) or '0200' (IOC-2 with CBA-2) CBA LVL1 with first GES = X'2602', second GES = IOH TA, third GES = IOH TD	Line down	No but NCP alert	F2
17		Cmd Reject-Rcv command when no LVL2 X7E='2000' (IOC-1 with CBA-1) or '0200' (IOC-2 with CBA-2) CBA LVL1 with first GES = X'2702', second GES = IOH TA, third GES = IOH TD	Line down	No but NCP alert	F2

<i>Table 11-55 (Page 2 of 4). 3746 Model 900 BER Type 9 Summary</i>					
BER ID	Abend Code (NCP)	Event Description	Recovery or PGM Action	MOSS ALERT	ALARM
18		Cmd Reject-Adapter not installed X7E='2000' (IOC-1 with CBA-1) or '0200' (IOC-2 with CBA-2) CBA LVL1 with first GES = X'2102', second GES = IOH TA, third GES = IOH TD	None	No but NCP alert	E9
19		Cmd Reject-Adapter Inoperative X7E='2000' (IOC-1 with CBA-1) or '0200' (IOC-2 with CBA-2) CBA LVL1 with first GES = X'2202', second GES = IOH TA, third GES = IOH TD	None	No but NCP alert	EA
1B	0933	PIO Error-Invalid Input IOH IOC Error LVL1 on IOH/PIO	NCP abend	No	E1
1D		DMA SP/AE during LNVT Read for a given CSS adapter X7E='2000' (IOC-1 with CBA-1) or '0200' (IOC-2 with CBA-2) CBA LVL1 with first GES = X'3503', second GES = IOH TA, third GES = SLID bytes 0-1, fourth GES = SLID bytes 2-3	CSS adapter down	ED	ED
1E		DMA SP/AE during CDF-E Write X7E='2000' (IOC-1 with CBA-1) or '0200' (IOC-2 with CBA-2) CBA LVL1 with first GES = X'3602', second GES = SLID bytes 0-1, third GES = SLID bytes 2-3	CBA down	E5	E5
30		NPSA parameter error Diagnostic code = '40' for NPSA Invalid command Diagnostic code = '41' for invalid NDPSA pointer Abnormal request reason code = 'C003' for NPSA Error-Invalid Halt cause code	Line down	No but NCP alert	F2
31		NDPSA parameter error Diagnostic Code = '10' for NDPSA invalid receive initial Diagnostic Code = '15' for Invalid NDPSA chain pointer Diagnostic Code = '16' for Invalid NDPSA buffer pointer	Line down	No but NCP alert	F2
32		NDPSA invalid command LVL2 notify with an halt code cause of '9009' in NPSA meaning invalid command or qualifier in NDPSA.	Line down	No but NCP alert	F2
33		Station NDPSA Invalid Command	Line station reset	No but NCP alert	F4
34		Line NDPSA invalid adapter LRID LVL2 notify with an halt code cause of '9002' in NPSA meaning invalid adapter LRID in NDPSA.	Line down	No but NCP alert	F2
35		LPSA invalid status LVL2 abnormal request with an halt code cause of 'A004,A005,A006' in NPSA meaning invalid LPSA status and respectively invalid reason code or diagnostic code or congestion flags.	Line down	No but NCP alert	F2
37		Invalid resource definition data LVL2 with cc = '02'	Line down	No but NCP alert	F2

<i>Table 11-55 (Page 3 of 4). 3746 Model 900 BER Type 9 Summary</i>					
BER ID	Abend Code (NCP)	Event Description	Recovery or PGM Action	MOSS ALERT	ALARM
38		Protocol hardware/software mismatch LVL2 with cc = '03'	Line down	No but NCP alert	F0
39		Line NDPSA error Diagnostic code = '04' for No ECB in NDPSA to pint on PIU NPSA diagnostic code = '05' for invalid offset or count in buffer prefix	Line down	No but NCP alert	F2
93		DMA Hardware Error X7E='2000' (IOC-1 with CBA-1) or '0200' (IOC-2 with CBA-2) CBA LVL1 with first GES = X'3702', second GES = SLID bytes 0-1, third GES = SLID bytes 2-3	CBA down	E7	E7
94		HPPB Hardware Error X7E='2000' (IOC-1 with CBA-1) or '0200' (IOC-2 with CBA-2) CBA LVL1 with GES-1st = X'1100'	CBA down	E6	E6
95		Adapter program reset issued by NCP level 1 failed twice (IOC error). X7E='0100' (IOC-1 with CBA-1) or '0001' (IOC-2 with CBA-2)	None	No	No
96		SAP to MOSS-E connection lost X7E='2000' (IOC-1 with CBA-1) or '0200' (IOC-2 with CBA-2) CBA LVL1 with GES-1st = X'1300'	None	F7	F7
97		IOC PIO Error LVL1 entered after NCP IOH instruction due to X7E = '0100'(IOC-1/CBA-1) or '0001'(IOC-2/CBA-2) and X76 = 'x8' or 'x4'	NCP retry	No	No
98		IOC PIO Error (threshold) Identical to BER 09 97	CBA down	E6	E6
99		Adapter LVL1-Invalid Error Status X7E='2000' (IOC-1 with CBA-1) or '0200' (IOC-2 with CBA-2)	CBA down	E8	E8
9B		IOC Error on PIO Set Hi/Lo Cmd As BER 09 98(97) but on specific IOH commands	CBA down	E6	E6
9C		PIO Get Line ID failed	None.	No	No
9C		PIO Get Line ID failed or PIO GLID failed (threshold)	CBA down	E6	E6
9D		CDF-E update error When CBA LVL1 with first GES = '43xx' as adapter CDF-E update inconsistent, second GES = adapter CDF-E entry bytes 0-1, third GES = adapter CDF-E entry byte 3-4, and so on according to xx as a multiple of 2. X7E='2000' (IOC-1 with CBA-1) or '0200' (IOC-2 with CBA-2)	CSS adapter down	EE	EE
9E		IOC PIO Error on GES	CBA down	E6	E6

3746-900 BER

<i>Table 11-55 (Page 4 of 4). 3746 Model 900 BER Type 9 Summary</i>					
BER ID	Abend Code (NCP)	Event Description	Recovery or PGM Action	MOSS ALERT	ALARM
9F		Any CBA LVL1 with NCP generation not supporting the CSS. X7E='2000' (IOC-1 with CBA-1) or '0200' (IOC-2 with CBA-2)	None	F8	F8
A1		Unexpected Interrupt LVL2	None	No	No
A1	0936	Unexpected Interrupt LVL2 (threshold)	NCP abend	E2	E2
B0		Time-out on command No answer received (time-out) on "Execute Request" but following "Halt" has been completed successfully (Halt Cause Code = '8401').	Line down	No but NCP alert	F3
B1		Line timeout on halt command. No answer received (time-out) on "Execute Request" and on following "Halt" command.	None	No	No
B1		Adapter timeout on halt command. No answer received (time-out) on "Execute Request" and on following "Halt" command.	CBA down	EE	EE
B2		Time-Out on failure recovery Time-out on CBC reporting recovery after CBC slot failure	CBA down	E6	E6

3746 Model 900 BER Type 9 Detailed BER Display

3746-900 BER Type 9 - IDs 10 and 15 to 19 These BERs are generated for transmit side errors (TD byte 1 = odd).: Format foS1, see page 11-159.

```

                                ELD DETAIL
SEL# hhh  FLAG hh DATE:dd/dd TIME:dd:dd TYPE:09 ID:hh
  <ERROR DESCRIPTION>                                <REFER.CODE IN CHAR.> CCCCCC
X7E:hhhh LAR:hhhh hhhh INTLVL:hh IAR:hhhhh X76:hhhh AITADNO:hh AITTYPE:hh
AITCONF:hh AITSTAT:hh AITPROT:hhhh L1BPIO76:hhhh L1BIOHTA:hhhh L1BIOHTD:hhhh
L1XGESFG:hh L1BERFLG:hh L1XSWADE:hhhh L1BPIOTA:hhhh
NPSA PARM:hhhhhhhh hhhhhhhh hhhhhhhh hhhhhhhh
NPSA STAT:hhhhhhh hhhhhhhh hhhhhhhh hhhhhhhh
1ST NDPSA:hhhhhhh hhhhhhhh hhhhhhhh hhhhhhhh hhhhhhhh hhhhhhhh hhhhhhhh
hhhhhhh NACBWQH:hhhh hhhh NACBLCQH:hhhh hhhh NACB1HCC:hhhh NACBFLAG:hh
NACBERPF:hh
                                                    PAGE 1 OF 2

===>

F1:END F2:MENU2 F3:ALARM F4:SUMMARY F5:LIST F7:PREVIOUS F8:NEXT

```

```

                                ELD DETAIL
SEL# hhh  FLAG hh DATE:dd/dd TIME:dd:dd TYPE:09 ID:hh
  <ERROR DESCRIPTION>                                <REFER.CODE IN CHAR.> CCCCCC
X-LXB:hhhhhhh hhhhhhhh hhhhhhhh hhhhhhhh hhhhhhhh
hhhhhhh hhhhhhhh hhhhhhhh hhhhhhhh X-CCBSTAT1:hhhh X-CCBEND1:hhhh
X-CCBBAR:hhhh X-CCBCTL:hh X-ATTECTL:hh
X-ATT:hhhhhhh hhhhhhhh hhhhhhhh hhhhhhhh hhhhhhhh
hhhhhhh hhhhhhhh hhhhhhhh
GES:hhhh hhhh hhhh hhhh hhhh hhhh
LKEFMT:hh
                                                    PAGE 2 OF 2

===>

F1:END F2:MENU2 F3:ALARM F4:SUMMARY F5:LIST F7:PREVIOUS F8:NEXT

```

3746-900 BER Type 9 - IDs 10 and 15 to 19 These BERs are generated for receive side errors (TD byte 1 = even).: Format foS2, see page 11-159.

```

                                ELD DETAIL
SEL# hhh  FLAG hh DATE:dd/dd TIME:dd:dd TYPE:09 ID:hh
<ERROR DESCRIPTION>                <REFER.CODE IN CHAR.> CCCCCC
X7E:hhhh LAR:hhhh hhhh INTLVL:hh IAR:hhhhh X76:hhhh AITADNO:hh AITTYPE:hh
AITCONF:hh AITSTAT:hh AITPROT:hhhh L1BPIO76:hhhh L1BIOHTA:hhhh L1BIOHTD:hhhh
L1XGESFG:hh L1BERFLG:hh L1XSWADE:hhhh L1BPIOTA:hhhh
LPSA PARM:hhhhhhhh hhhhhhhh hhhhhhhh hhhhhhhh
LPSA STAT:hhhhhhhh hhhhhhhh hhhhhhhh hhhhhhhh
1ST LDPSA:hhhhhhhh hhhhhhhh hhhhhhhh hhhhhhhh hhhhhhhh hhhhhhhh hhhhhhhh
hhhhhhh NACBWQH:hhhh hhhh NACBLCQH:hhhh hhhh NACB1HCC:hhhh NACBFLAG:hh
NACBERPF:hh

                                PAGE 1 OF 2

===>

F1:END F2:MENU2 F3:ALARM F4:SUMMARY F5:LIST F7:PREVIOUS F8:NEXT
```

```

                                ELD DETAIL
SEL# hhh  FLAG hh DATE:dd/dd TIME:dd:dd TYPE:09 ID:hh
<ERROR DESCRIPTION>                <REFER.CODE IN CHAR.> CCCCCC
X-LXB:hhhhhhhh hhhhhhhh hhhhhhhh hhhhhhhh hhhhhhhh
hhhhhhh hhhhhhhh hhhhhhhh hhhhhhhh X-CCBSTAT1:hhhh X-CCBEND1:hhhh
X-CCBBAR:hhhh X-CCBCTL:hh X-ATTECTL:hh
X-ATT:hhhhhhhh hhhhhhhh hhhhhhhh hhhhhhhh hhhhhhhh
hhhhhhh hhhhhhhh hhhhhhhh
GES:hhhh hhhh hhhh hhhh hhhh hhhh
LKEFMT:hh

                                PAGE 2 OF 2

===>

F1:END F2:MENU2 F3:ALARM F4:SUMMARY F5:LIST F7:PREVIOUS F8:NEXT
```

3746-900 BER Type 9 - IDs 30 to 34 and 39: These BERs are generated for TD byte 0 bits 2-3 = 00 (line interface). Format foS3, see page 11-160.

```

                                ELD DETAIL
SEL# hhh  FLAG hh DATE:dd/dd TIME:dd:dd TYPE:09 ID:hh
<ERROR DESCRIPTION>                                <REFER.CODE IN CHAR.> CCCCCC
TA:hhhh TD:hhhh
NPSA PARM:hhhhhhh hhhhhhhh hhhhhhhh hhhhhhhh
NPSA STAT:hhhhhhh hhhhhhhh hhhhhhhh hhhhhhhh
LPSA PARM:hhhhhhh hhhhhhhh hhhhhhhh hhhhhhhh
LDPSA:hhhhhhh hhhhhhhh hhhhhhhh hhhhhhhh hhhhhhhh hhhh
1ST NDPSA:hhhhhhh hhhhhhhh hhhhhhhh hhhhhhhh hhhhhhhh hhhh
SLID:hhhh hhhh NACBFLAG:hh NACBERPF:hh
NACBWQH:hhhh hhhh NACBFLCQH:hhhh hhhh NACB1HCC:hhhh

                                PAGE 1 OF 2

===>

F1:END F2:MENU2 F3:ALARM F4:SUMMARY F5:LIST F7:PREVIOUS F8:NEXT

```

```

                                ELD DETAIL
SEL# hhh  FLAG hh DATE:dd/dd TIME:dd:dd TYPE:09 ID:hh
<ERROR DESCRIPTION>                                <REFER.CODE IN CHAR.> CCCCCC
R-LXB:hhhhhhh hhhhhhhh hhhhhhhh hhhhhhhh hhhhhhhh hhhhhhhh hhhhhhhh hhhhhhhh
hhhhhhh X-CCBSTAT1:hhhh X-CCBEND1:hhhh X-CCBBAR:hhhh
X-CCBCTL:hh X-ATTECTL:hh
X-ATT:hhhhhhh hhhhhhhh hhhhhhhh hhhhhhhh hhhhhhhh hhhhhhhh hhhhhhhh hhhhhhhh
SSBSSCF/CUBBSCF:hhhh LKEFMT:hh
BUFFER:hhhhhhh hhhhhhhh hhhhhhhh

                                PAGE 2 OF 2

===>

F1:END F2:MENU2 F3:ALARM F4:SUMMARY F5:LIST F7:PREVIOUS F8:NEXT

```

3746-900 BER Type 9 - IDs 30 to 32 and 39: These BERs are generated for TD byte 0 bits 2-3 = 01 (CBA/PRC interface) or 10 (trace interface). Format foS4, see page 11-160.

```

                                ELD DETAIL
SEL# hhh  FLAG hh DATE:dd/dd TIME:dd:dd TYPE:09 ID:hh
<ERROR DESCRIPTION>                <REFER.CODE IN CHAR.> CCCCCC
TA:hhhh TD:hhhh
NPSA PARM:hhhhhhhh hhhhhhhh hhhhhhhh hhhhhhhh
NPSA STAT:hhhhhhhh hhhhhhhh hhhhhhhh hhhhhhhh
LPSA PARM:hhhhhhhh hhhhhhhh hhhhhhhh hhhhhhhh
LDPSA:hhhhhhhh hhhhhhhh hhhhhhhh hhhhhhhh hhhhhhhh hhhhhhhh
1ST NDPSA:hhhhhhhh hhhhhhhh hhhhhhhh hhhhhhhh hhhhhhhh hhhhhhhh
hhhhhhhh hhhhhhhh SLID:hhhh hhhh NACBFLAG:hh NACBRTYP:hh LACBFLAG:hh R-LXBSTFLD:hh
TRACE PT1: CCTSTATE CCTSNPM CCTRTT CTOFLAG CTBAR CTBKTMR LVTSTAT
                hh      hh      hh      hh      hh      hh      hh
                                                    PAGE 1 OF 2
===>
F1:END F2:MENU2 F3:ALARM F4:SUMMARY F5:LIST F7:PREVIOUS F8:NEXT

```

```

                                ELD DETAIL
SEL# hhh  FLAG hh DATE:dd/dd TIME:dd:dd TYPE:09 ID:hh
<ERROR DESCRIPTION>                <REFER.CODE IN CHAR.> CCCCCC
TRACE PT2: CCTSTATE CCTSNPM CCTRTT CTOFLAG CTBAR CTBKTMR LVTSTAT
                hh      hh      hh      hh      hh      hh      hh
AITTYPE:hh
                                                    PAGE 2 OF 2
===>
F1:END F2:MENU2 F3:ALARM F4:SUMMARY F5:LIST F7:PREVIOUS F8:NEXT

```

3746-900 BER Type 9 - ID 35: Format foS5, see page 11-161.

```

                                ELD DETAIL
SEL# hhh  FLAG hh DATE:dd/dd TIME:dd:dd TYPE:09 ID:hh
<ERROR DESCRIPTION>                <REFER.CODE IN CHAR.> CCCCCC
TA:hhhh TD:hhhh          LPSA PARM:hhhhhhhh hhhhhhhh hhhhhhhh hhhhhhhh
LPSA STAT:hhhhhhhh hhhhhhhh hhhhhhhh hhhhhhhh
LDPSA:hhhhhhhh hhhhhhhh hhhhhhhh hhhhhhhh hhhhhhhh hhhh
NACBFLAG:hh NACBRTYP:hh LACBFLAG:hh LXBSTFLD:hh
TRACE PT1: CCTSTATE CCTSNPM CCTRTT CTOFLAG CTBAR CTBKTMR LVTSTAT
                hh      hh      hh      hh      hhhh      hhhh      hh
TRACE PT2: CCTSTATE CCTSNPM CCTRTT CTOFLAG CTBAR CTBKTMR LVTSTAT
                hh      hh      hh      hh      hhhh      hhhh      hh
AITTYPE:hh
===>
F1:END F2:MENU2 F3:ALARM F4:SUMMARY F5:LIST F7:PREVIOUS F8:NEXT

```

3746-900 BER Type 9 - IDs 37 and 38: Format foS6, see page 11-161.

```

                                ELD DETAIL
SEL# hhh  FLAG hh DATE:dd/dd TIME:dd:dd  TYPE:09  ID:hh
<ERROR DESCRIPTION>                <REFER.CODE IN CHAR.> CCCCCCCC
TA:hhhh TD:hhhh
LPSA PARM:hhhhhhh hhhhhhhh hhhhhhhh hhhhhhhh
LPSA STAT:hhhhhhh hhhhhhhh hhhhhhhh hhhhhhhh
LDPSA:hhhhhhh hhhhhhhh hhhhhhhh hhhhhhhh hhhhhhhh hhhh
NACBFLAG:hh NACBRTYP:hh LACBFLAG:hh R-LXBSTFLD:hh
DATA:hhhh hhhh LKEFMT:hh AITTYPE:hh

===>

F1:END  F2:MENU2  F3:ALARM  F4:SUMMARY  F5:LIST  F7:PREVIOUS  F8:NEXT

```

3746-900 BER Type 9 - ID A1: Format foS7, see page 11-162.

```

                                ELD DETAIL
SEL# hhh  FLAG hh DATE:dd/dd TIME:dd:dd  TYPE:09  ID:hh
<ERROR DESCRIPTION>                <REFER.CODE IN CHAR.> CCCCCCCC
NPSA PARM:hhhhhhh hhhhhhhh hhhhhhhh hhhhhhhh
NPSA STAT:hhhhhhh hhhhhhhh hhhhhhhh hhhhhhhh
CCBBAR:hhhh TA:hhhh TD:hhhh
CNT:hhh

===>

F1:END  F2:MENU2  F3:ALARM  F4:SUMMARY  F5:LIST  F7:PREVIOUS  F8:NEXT

```

3746-900 BER Type 9 - IDs B1 and B2: Format foS8, see page 11-162.

```

                                ELD DETAIL
SEL# hhh  FLAG hh DATE:dd/dd TIME:dd:dd  TYPE:09  ID:hh
<ERROR DESCRIPTION>                <REFER.CODE IN CHAR.> CCCCCC
TA:hhhh TD:hhhh
NPSA PARM:hhhhhhhh hhhhhhhh hhhhhhhh hhhhhhhh
NPSA STAT:hhhhhhhh hhhhhhhh hhhhhhhh hhhhhhhh
LPSA PARM:hhhhhhhh hhhhhhhh hhhhhhhh hhhhhhhh
NACBFLAG:hh NACBERPF:hh NACBWQH:hhhhhhh NACBLCQH:hhhhhhh NACB1HCC:hhhh
R-LXB:hhhhhhhh hhhhhhhh hhhhhhhh hhhhhhhh hhhhhhhh hhhhhhhh hhhhhhhh
hhhhhhh X-CCBSTAT1:hhhh X-CCBEND1:hhhh X-CCBBAR:hhhh X-CCBCTL:hh X-ATTECTL:hh
X-ATT:hhhhhhhh hhhhhhhh hhhhhhhh hhhhhhhh hhhhhhhh hhhhhhhh hhhhhhhh

                                PAGE 1 OF 2

===>

F1:END  F2:MENU2  F3:ALARM  F4:SUMMARY  F5:LIST  F7:PREVIOUS  F8:NEXT

```

```

                                ELD DETAIL
SEL# hhh  FLAG hh DATE:dd/dd TIME:dd:dd  TYPE:09  ID:hh
<ERROR DESCRIPTION>                <REFER.CODE IN CHAR.> CCCCCC
AITADNO:hh AITTYPE:hh AITCONF:hh AITSTAT:hh AITPROT:hhhh LKEFMT:hh
TRACE PT1: CCTSTATE CCTSMP CTRTT CTOFLAG CTBAR CTBKTMR LTVTSTAT
             hh      hh      hh      hh      hhhh      hhhh      hh
TRACE PT2: CCTSTATE CCTSMP CTRTT CTOFLAG CTBAR CTBKTMR LTVTSTAT
             hh      hh      hh      hh      hhhh      hhhh      hh

                                PAGE 2 OF 2

===>

F1:END  F2:MENU2  F3:ALARM  F4:SUMMARY  F5:LIST  F7:PREVIOUS  F8:NEXT

```

3746-900 BER Type 9 - IDs 11 to 14, 1B, 93 to 99, 9B to 9F: Format foS9, see page 11-163.

```

                                ELD DETAIL
SEL# hhh  FLAG hh DATE:dd/dd TIME:dd:dd  TYPE:09  ID:hh
<ERROR DESCRIPTION>                <REFER.CODE IN CHAR.> CCCCCC
X7E:hhhh LAR:hhhh hhhh INTLVL:hh IAR:hhhhh X76:hhhh AITADNO:hh AITTYPE:hh
AITCONF:hh AITSTAT:hh AITPROT:hhhh LIBPI076:hhhh L1BIOHTA:hhhh
L1BIOHTD:hhhh L1XGESFG:hh L1BERFLG:hh L1XSWADE:hhhh L1BPIOTA:hhhh
GES:hhhh hhhh hhhh hhhh hhhh hhhh
CDF-E: hhhhhhhh

===>Format 5 general

F1:END  F2:MENU2  F3:ALARM  F4:SUMMARY  F5:LIST  F7:PREVIOUS  F8:NEXT

```

3746-900 BER Type 9 - ID 1D: Format foS10, see page 11-163.

```

                                ELD DETAIL
SEL# hhh  FLAG hh DATE:dd/dd TIME:dd:dd TYPE:09 ID:hh
<ERROR DESCRIPTION>                <REFER.CODE IN CHAR.> CCCCCC
X7E:hhhh LAR:hhhh hhhh INTLVL:hh IAR:hhhhhh X76:hhhh AITADNO:hh AITTYPE:hh
AITCONF:hh AITSTAT:hh AITPROT:hhhh L1BPIO76:hhhh L1BIOHTA:hhhh
L1BIOHTD:hhhh L1XGESFG:hh L1BERFLG:hh L1XSWADE:hhhh L1BPIOTA:hhh
GES:hhhh hhhh hhhh hhhh hhhh hhhh
LNVT SEG ADDRESS: hhhhhhhh

===>

F1:END F2:MENU2 F3:ALARM F4:SUMMARY F5:LIST F7:PREVIOUS F8:NEXT

```

3746-900 BER Type 9 - ID 1E: Format foS11, see page 11-163.

```

                                ELD DETAIL
SEL# hhh  FLAG hh DATE:dd/dd TIME:dd:dd TYPE:09 ID:hh
<ERROR DESCRIPTION>                <REFER.CODE IN CHAR.> CCCCCC
X7E:hhhh LAR:hhhh hhhh INTLVL:hh IAR:hhhhhh X76:hhhh AITADNO:hh AITTYPE:hh
AITCONF:hh AITSTAT:hh AITPROT:hhhh L1BPIO76:hhhh L1BIOHTA:hhhh
L1BIOHTD:hhhh L1XGESFG:hh L1BERFLG:hh L1XSWADE:hhhh L1BPIOTA:hhhh
GES:hhhh hhhh hhhh hhhh hhhh hhhh
CDF-E: hhhhhhhh

===>

F1:END F2:MENU2 F3:ALARM F4:SUMMARY F5:LIST F7:PREVIOUS F8:NEXT

```

3746-900 BER Type 9 - Field Description

For fields not listed in the following table, use the NCP documentation for field description.

Field Name	Meaning	Refer to
AITADNO	TA data registerbyte 0 bits 3-7	page 3-36
AITPROT	Adapter protocol status	page 11-157
AITCONF	Adapter configuration	page 11-157
AITSTAT	Adapter status indicator	page 11-157
AITTYPE	Adapter type	page 11-157
CNT	Repetition counter (ber flooding). Number of times the BER appeared.	-
GES	Get error status	page 11-157
IAR	IAR of interrupt level.	page 2-42
INTLVL	Interrupt level	-
LAR	Lagging Address Register (X'74').	page 2-42
LKEFMT	Functional group	page 11-158
L1BERFLG	Box event record flags	page 11-158
L1BIOHTA/ TA	IOHI image -- TA data register (TA: hhhh means data bytes 0 and 1).	page 3-36
L1BIOHTD/ TD	IOHI image -- TD data adapter specific bytes (TD: hhhh means data bytes 0 and 1).	-
L1XGESFG	Invalid GES indicators flag byte	page 11-158
L1XSWADE	Switch adapter error register.	Unused
X76	X'76' - IOC error summary register.	page 2-34
X7E	X'7E' - CCU level 1 interrupt.	page 2-40

<i>Table 11-57 (Page 1 of 2). 3746-900 BER Type 9 Field Details</i>		
Field Name	Bit Pattern or Hex Value	Meaning
AITCONF	1 1 1 1 x x 1 x	Adapter configuration Adapter not installed Adapter not operative Adapter not attached to this CCU Unused Unused Unused CSS coupler is not primary Unused
AITPROT	Byte 0 1 1 1 x x x x x Byte 1 1 1 1 x x x x x	Adapter protocol status Adapter slot protocol is down Trace protocol is down Adapter slot and trace protocol are down Unused SDLC mapper is down ESCON mapper is down TRA mapper is down Unused
AITSTAT	Byte 0 1 1 x 1 x 1 1 x Byte 1 1 1 1 1 1 x x 1	Adapter status indicator Line adapter status indicator Interrupt from the line adapter when disconnected IOH instruction to line adapter failed twice Unused Line adapter down due to line adapter LVL1 interrupt Unused Line adapter down due to exceeding incident limit Line adapter down due to MOSS command Unused Channel adapter status indicator Channel adapter active for NCP Channel adapter active for EP Channel adapter active for programmed resource Channel adapter is 'install in progress' Channel adapter is CACM mode disconnected Unused Unused Channel adapter is permmanently down
AITTYPE	xxxx xxxx	Adapter type X'00' = Undefined processor X'01' = CADs X'02' = BCCA X'10' = TSS X'20' = HPTSS X'30' = TRA X'50' = CBA X'51' = CBSP X'53' = ESCP X'54' = TRP
GES (1st)	Byte 0 Byte 1	Get error status Byte 0 Bits 0-3 = Error category Byte 0 Bits 4-7 = Error type Byte 1 Bits 0-7 = Total number of associated GESs after this one.

Table 11-57 (Page 2 of 2). 3746-900 BER Type 9 Field Details		
Field Name	Bit Pattern or Hex Value	Meaning
LKEFMT	<p>x</p> <p>. x</p> <p>. . 0 0</p> <p>. . . . x x x x</p>	<p>x = 0 : Link definition x = 1 : Station definition</p> <p>x = 0 : Physical definition x = 1 : Logical definition</p> <p>Unused</p> <p>Protocal type definition xxxx = 0000 : None xxxx = 0010 : ESCON xxxx = 0011 : TRA</p>
L1BERFLG	<p>x</p> <p>. 1</p> <p>. . 1</p> <p>. . . 1</p> <p>. . . . 1</p> <p>. 1</p> <p>. 1</p> <p>. 1</p>	<p>Box event record flags</p> <p>x = 0 : Control program is EP x = 1 : Control program is NCP or PEP</p> <p>Adapter down</p> <p>Control program put adapter down</p> <p>Redrive has been disabled (NCP only) or error on invalid ESC (EP only)</p> <p>MOSS CACM timeout detected (3745 only)</p> <p>Error on get error status</p> <p>CA is being disabled</p> <p>IOH or IOHI on level 1 failed twice</p>
L1XGESFG	<p>1</p> <p>. 1</p> <p>. . 1</p> <p>. . . 1</p> <p>. . . . x x x x</p>	<p>Invalid GES indicators flag byte</p> <p>Invalid GES error category</p> <p>Invalid GES error type</p> <p>Invalid GES count</p> <p>Invalid GES TA/TD</p> <p>Unused</p>

3746 Model 900 BER Type 09 - Formats

Format foS1		Format foS2	
IDs: 10 and 15 to 19		IDs: 10 and 15 to 19	
Bytes	Meaning	Bytes	Meaning
1-27	Header	1-27	Header
28-29	TYPE-ID	28-29	TYPE-ID
30	LOST	30	LOST
31-32	Abend	31-32	Abend
33-34	X7E	33-34	X7E
35-38	LAR	35-38	LAR
39	INTLVL	39	INTLVL
40-42	IAR	40-42	IAR
43-44	X76	43-44	X76
45	AITADNO	45	AITADNO
46	AITTYPE	46	AITTYPE
47	AITCONF	47	AITCONF
48	AITSTAT	48	AITSTAT
49-50	AITPROT	49-50	AITPROT
51-52	L1BPI076	51-52	L1BPI076
53-54	L1BIOHTA	53-54	L1BIOHTA
55-56	L1BIOHTD	55-56	L1BIOHTD
57	L1XGESFG	57	L1XGESFG
58	L1BERFLG	58	L1BERFLG
59-60	L1XSWADE	59-60	L1XSWADE
61-62	L1BPOHTA	61-62	L1BPOHTA
63-94	NPSA	63-94	LPSA
95-126	NDPSA	95-126	NDPSA
127-130	NACBWQH	127-130	NACBWQH
131-134	NACBLCQH	131-134	NACBLCQH
135-136	NACB1HCC	135-136	NACB1HCC
137	NACBFLAG	137	NACBFLAG
138	NACBERPF	138	NACBERPF
139-174	X-LXB	139-174	X-LXB
175-176	X-CCBSTAT1	175-176	X-CCBSTAT1
177-178	X-CCBEND1	177-178	X-CCBEND1
179-180	X-CCBBAR	179-180	X-CCBBAR
181	X-CCBCTL	181	X-CCBCTL
182	X-ATTECTL	182	X-ATTECTL
183-214	X-ATT	183-214	X-ATT
215-226	GESs	215-226	GESs
227	LKEFNT	227	LKEFNT

Figure 11-21 (Part 1 of 5). 3746 Model 900 BER Formats

Format foS3		Format foS4	
IDs: 30 to 34 and 39		ID : 30 to 32 and 39	
Bytes	Meaning	Bytes	Meaning
1-27	Header	1-27	Header
28-29	TYPE-ID	28-29	TYPE-ID
30	LOST	30	LOST
31-32	Abend	31-32	Abend
33-34	TA	33-34	TA
35-36	TD	35-36	TD
37-52	NPSA PARM	37-52	NPSA PARM
53-68	NPSA STAT	53-68	NPSA STAT
69-84	LPSA PARM	69-84	LPSA PARM
85-110	LDPSA	85-110	LDPSA
111-116	Unused	111-116	Unused
117-142	NDPSA	117-142	NDPSA
143-148	Unused	143-148	Unused
149-152	SLID	149-152	SLID
153	NACBFLAG	153	NACBFLAG
154	NACBERPF	154	NACBRTYP
155-158	NACBWQH	155	LACBFLAG
159-162	NACBLCQH	156	R-LXBSTFLD
163-164	NACB1HCC	157	PT1 CCTSTATE
165-200	R-LXB	158	PT1 CCTSNPM
201-202	X-CCBSTAT1	159	PT1 CCTRTT
203-204	X-CCBEND1	160	PT1 CCTOFLAG
205-206	X-CCBBAR	161-162	PT1 CCTBAR
207	X-CCBCTL	163-164	PT1 CTBKTMR
208	X-ATTECTL	165	PT1 LTVTSTAT
209-240	X-ATT	166	Unused
241-242	SSBSSCF/CUBBSCF	167	PT2 CCTSTATE
243	LKEFNT	168	PT2 CCTSNPM
244-255	BUFFER	169	PT2 CCTRTT
		170	PT2 CCTOFLAG
		171-172	PT2 CCTBAR
		173-174	PT2 CTBKTMR
		175	PT2 LTVTSTAT
		176	AITTYPE

Figure 11-21 (Part 2 of 5). 3746 Model 900 BER Formats

Format fo55		Format fo56	
ID : 35		IDs: 37 and 38	
Bytes	Meaning	Bytes	Meaning
1-27	Header	1-27	Header
28-29	TYPE-ID	28-29	TYPE-ID
30	LOST	30	LOST
31-32	Abend	31-32	Abend
33-34	TA	33-34	TA
35-36	TD	35-36	TD
37-52	LPSA PARM	37-52	LPSA PARM
53-68	LPSA STAT	53-68	LPSA STAT
69-100	LDPSA	69-100	LDPSA
101	NACBFLAG	101	NACBFLAG
102	NACBRTYP	102	NACBRTYP
103	LACBFLAG	103	LACBFLAG
104	R-LXBSTFLD	104	R-LXBSTFLD
105	PT1 CCTSTATE	105-108	DATA
106	PT1 CCTSNPM	109	LKEFNT
107	PT1 CCTRTT	110	AITTYPE
108	PT1 CCTOFLAG	111-112	Repetit. BER count
109-110	PT1 CCTBAR		
111-112	PT1 CCTBKTMR		
113	PT1 LTVTSTAT		
114	Unused		
115	PT2 CCTSTATE		
116	PT2 CCTSNPM		
117	PT2 CCTRTT		
118	PT2 CCTOFLAG		
119-120	PT2 CCTBAR		
121-122	PT2 CCTBKTMR		
123	PT2 LTVTSTAT		
124	AITTYPE		

Figure 11-21 (Part 3 of 5). 3746 Model 900 BER Formats

Format foS7		Format foS8	
ID : A1		IDs: B1 and B2	
Bytes	Meaning	Bytes	Meaning
1-27	Header	1-27	Header
28-29	TYPE-ID	28-29	TYPE-ID
30	LOST	30	LOST
31-32	Abend	31-32	Abend
33-48	NPSA PARM	33-34	TA
49-64	NPSA STAT	35-36	TD
65-66	CCBBAR	37-52	NPSA PARM
67-68	TA	53-68	NPSA STAT
69-70	TD	69-84	LPSA PARM
71-72	Count	85	NACBFLAG
		86	NACBERPF
		87-90	NACBWQH
		91-94	NACBLCQH
		95-96	NACBIHCC
		97-132	R-LXB
		133-134	X-CCBSTAT1
		135-136	X-CCBEND1
		137-138	X-CCBBAR
		139	X-CCBCTL
		140	X-ATTECTL
		141-172	X-ATT
		173	AITADNO
		174	AITTYPE
		175	AITCONF
		176	AITSTAT
		177-178	AITPROT
		179	LKEFMT
		180	Unused
		181	PT1 CCTSTATE
		182	PT1 CCTSNPM
		183	PT1 CCTRTT
		184	PT1 CCTOFLAG
		185-186	PT1 CCTBAR
		187-188	PT1 CCTBKTMR
		189	PT1 LTVTSTAT
		190	Unused
		191	PT2 CCTSTATE
		192	PT2 CCTSNPM
		193	PT2 CCTRTT
		194	PT2 CCTOFLAG
		195-196	PT2 CCTBAR
		197-198	PT2 CCTBKTMR
		199	PT2 LTVTSTAT

Figure 11-21 (Part 4 of 5). 3746 Model 900 BER Formats

Format foS09	
IDs: 11-14, 1B, 93-99, 9B-9F	
Bytes	Meaning
1-27	Header
28-29	TYPE-ID
30	LOST
31-32	Abend
33-34	X7E
35-38	LAR
39	INTLVL
40-42	IAR
43-44	X76
45	AITADNO
46	AITTYPE
47	AITCONF
48	AITSTAT
49-50	AITPROT
51-52	LIBPIO76
53-54	LIBIOHTA
55-56	LIBIOHTD
57	LIXGESFG
58	LIBERFLG
59-60	LIXSWADE
61-62	LIBPOHTA
63-66	CDF-E (ID 12 only)
67-78	GESs

Format foS10	
IDs: 1D	
Bytes	Meaning
1-27	Header
28-29	TYPE-ID
30	LOST
31-32	Abend
33-34	X7E
35-38	LAR
39	INTLVL
40-42	IAR
43-44	X76
45	AITADNO
46	AITTYPE
47	AITCONF
48	AITSTAT
49-50	AITPROT
51-52	LIBPIO76
53-54	LIBIOHTA
55-56	LIBIOHTD
57	LIXGESFG
58	LIBERFLG
59-60	LIXSWADE
61-62	LIBPOHTA
63-74	GESs
75-78	LNVT SEG ADDRESS

Format foS11	
ID : 1E	
Bytes	Meaning
1-27	Header
28-29	TYPE-ID
30	LOST
31-32	Abend
33-34	X7E
35-38	LAR
39	INTLVL
40-42	IAR
43-44	X76
45	AITADNO
46	AITTYPE
47	AITCONF
48	AITSTAT
49-50	AITPROT
51-52	LIBPIO76
53-54	LIBIOHTA
55-56	LIBIOHTD
57	LIXGESFG
58	LIBERFLG
59-60	LIXSWADE
61-62	LIBPOHTA
63-74	GESs
75-78	CDF-E

Figure 11-21 (Part 5 of 5). 3746 Model 900 BER Formats

NCP CA BER Type 10

CA BER Type 10 - Summary

BER ID	Abend Code (NCP)	Event Description	Recovery or PGM Action	ALERT	ALARM
10	0915	<ul style="list-style-type: none"> CADS: Invalid ESC address used (EP or NEO are the CA owner) <ul style="list-style-type: none"> Mismatch between ESC addresses range defined in NCP/PEP sysgen and in MOSS CDF for involved CA. Program error (for example, possible overwrite of control blocks where ESC values are kept) if found in normal operations BCCA: ESC addresses not allowed on this type of CA. 	NCP re-IPL	NO	NO
14	0910	Address exception (AIO) (X'76' bit 0.0 or 1.0 ON)	NCP re-IPL	NO	NO
16	0911	Storage protect (AIO) (X'76' bit 0.1 or 1.1 ON)	NCP re-IPL	NO	NO
18	0912	Invalid CA selection in control program (attempt to select a non-installed CA). Control program issuing an output X'07' with either bit 0.2 or 0.3 set and bits 0.4, 0.6 indicating select bits for a CA that is not installed.	NCP re-IPL	NO	NO
1B	0913	Invalid IOH/IOHI input to CA (for example input to register which cannot be read) X'7E' bit 0.5 ON	NCP re-IPL	NO	NO
1C	0914	Output sequence issued in error to CA X'0D' bit 1.0 ON	NCP re-IPL	NO	NO
1E	0913	Invalid IOH/IOHI output to CA output X'0D', X'0E', or X'0F'	NCP re-IPL	NO	NO
1F	0913	Invalid IOH/IOHI output to CA (hardware detected) X'7E' bit 0.5 ON	NCP re-IPL	NO	NO
34	091F	Level 3 IPL configuration check <ul style="list-style-type: none"> Stacked status cleared by initial select for the 1st time, or transfer of final status but not on the IPLing CA. built for the non-IPLing CA PRI built for the IPLing CA 	NCP re-IPL	NO	NO
35	0	ESC address (from host) not within range (PEP on level 3 interrupt) Mismatch between ESC addresses range defined in NCP/PEP sysgen and in MOSS CDF for involved CA.		NO	NO
80	0	Autoselection error: IOH IN X'0F' failed (X'09' and X'0A' contain 'FEFE')	Retry cmd in X'0F'		
80	0920	Autoselection error (limit threshold) <ul style="list-style-type: none"> X'76' bit 0.4 ON for IOC1 time out, or X'76' bits 0.0 to 0.3 contain '0010'. 	NCP re-IPL	NO	NO
80	0	Autoselection error (limit threshold) <ul style="list-style-type: none"> X'76' bit 0.4 ON for IOC1 time out, or X'76' bits 0.0 to 0.3 contain '0101'. 	CA down	50	50
80	0920	Autoselection error (limit threshold) <ul style="list-style-type: none"> X'76' bit 0.4 ON for IOC1 time out, or X'76' bits 0.0 to 0.3 contain '0101'. 	NCP re-IPL	NO	NO

<i>Table 11-58 (Page 2 of 5). CA BER Type 10 Summary</i>					
BER ID	Abend Code (NCP)	Event Description	Recovery or PGM Action	ALERT	ALARM
81	0	Failure to read X'08', or more than one CA in error from the X'08'. CA dropped from the autoselection chain bit 0 in CA X'08' byte 0	CA down	50	50
81	0	<ul style="list-style-type: none"> • CA dropped from the autoselection chain in CA X'08' byte 0, CAs bit = 0 • Non-contiguous CAs in the autoselection chain All CAs on the IOC bus are removed from the chain.		NO	NO
82	0	CA cannot be selected in level 1, not possible to issue IN CA X'08	CA down	50	50
82		CA cannot be selected in level 1 (last CA, no INN traffic)	NCP re-IPL	NO	40
83		Autoselection error, 1 CA identified		NO	NO
84		Autoselection error, several errors		NO	NO
85	917 919 91A	CA not accessible (not attached, not initialized) Unresolved AIO Unresolved adapter error PIO error on a CA		NO	NO
86	917 919 91A	CA not operative Unresolved AIO Unresolved adapter error PIO error on a CA		NO	NO
87	917 919 91A	Interrupt from a disable CA Unresolved AIO Unresolved adapter error PIO error on a CA		NO	NO
88	917 919 91A	Unexpected level 1 in concurrent maintenance Unresolved AIO Unresolved adapter error PIO error on a CA		NO	NO
89	917 919 91A	Unexpected level 1 from CA CACM disconnect or with CA install in progress AIO threshold reached Unresolved interrupt PIO threshold reached		NO	NO
90	0	CADS: Invalid ESC address (PEP or NEO are not the CA owner). ESC addresses not active on the CA. BCCA: ESC addresses not allowed on this type of CA.	Invalid ESC address (PEP or NEO are not the CA owner, NCP is the owner on an ESC address compare)	NCP retry	NO
NO					
90	0	Invalid ESC address (limit threshold)	CA down	50	50
90		Invalid ESC address (last CA, no INN) All CAs have been disabled	NCP re-IPL	NO	NO

CA BER

Table 11-58 (Page 3 of 5). CA BER Type 10 Summary

BER ID	Abend Code (NCP)	Event Description	Recovery or PGM Action	ALERT	ALARM
91	0	AIO error <ul style="list-style-type: none"> • X'75' bit 0.0 and 1.0 OFF • X'76' bit 0.4 ON for IOC1 time out • X'76' bit 0.5 or 1.5 for IOC1 bus IN parity error • X'76' bit 0.6 in both cases (AIO) • X'76' bits 0.0, 0.1, 0.2, 0.3 contain the IOC status at the time of error 	NCP retry	NO	NO
91	0	AIO error (limit threshold)	CA down	50	50
91		AIO error (last CA, no INN), all CAs have been disabled	NCP re-IPL	NO	NO
92	0922	Level 1 from CA during recovery (interrupt from a CA which is already being disabled by error recovery procedures as a result of level 1 checks). Indicates the probable failure of the disable sequence	NCP re-IPL	NO	40
93	0	Driver/receiver check X'0D' bit 1.6 or 1.7 ON	NCP retry	NO	NO
93	0	Driver/receiver check (limit threshold)	CA down	50	50
93		Driver/receiver check (last CA, no INN) All CAs have been disabled	NCP re-IPL	NO	NO
94	0	Level 1 from a CA not generated active X'7E' bit 0.5 or 1.5 ON	NCP retry	NO	NO
94	0921	Level 1 from a CA not generated active (limit threshold)	NCP re-IPL	NO	NO
96	0	Channel bus IN check (X'0D' bit 1.3 or 1.5 ON)	NCP retry	NO	NO
96	0	Channel bus IN check (limit threshold)	CA down	50	50
96		Channel bus IN check (last CA, no INN), all CAs have been disabled	NCP re-IPL	NO	40
97	0	PIO error (Input or output IOH failed) <ul style="list-style-type: none"> • X'76' bit 0.4 ON for IOC1 time out • X'76' bit 0.5 for IOC1 bus IN parity error X'76' bit 0.6 in both cases 	NCP retry	NO	NO
97	0	PIO error (limit threshold)	CA down	50	50
97	091A	PIO error (last CA, no INN), all CAs have been disabled	NCP re-IPL	NO	40
98	0	Internal adapter error: <ul style="list-style-type: none"> • X'7E' bit 0.5 or 1.5 ON • X'0E' bits to indicate CAs Control program checks the level 3 instruction that failed. <ul style="list-style-type: none"> • If it is a valid IOH/IOHI, retry the instruction in the interrupted level • If it is not a valid IOH/IOHI, attempt to disable the CA 	NCP retry	NO	NO
98	09F0	Internal adapter error : <ul style="list-style-type: none"> • Final status transfer. Not enough information available to recover when a data/status interrupt is pending during level 1 processing 	NCP re-IPL	NO	NO

Table 11-58 (Page 4 of 5). CA BER Type 10 Summary

BER ID	Abend Code (NCP)	Event Description	Recovery or PGM Action	ALERT	ALARM
98	09F1	Internal adapter error : <ul style="list-style-type: none"> Status byte cleared (X'00' bit 0.6) Not enough information available to recover when an Initial Selection Interrupt is pending during level 1 processing.	NCP re-IPL	NO	NO
98	0	Internal adapter error (limit threshold)	CA down	50	50
98		Internal adapter error (last CA, no INN), all CAs have been disabled	NCP re-IPL	NO	NO
99	0	Ground fault, X'0D' bit 1.4 ON	NCP retry	NO	NO
99	0	Ground fault (limit threshold)	CA down	50	50
9A	0920	IOH failed in level 1, abort AIO recovery Control program cannot get the registers needed to determine the error	NCP re-IPL	NO	NO
9B	0920	IOH failed in level 1, abort PIO recovery <ul style="list-style-type: none"> IOH required for the recovery failed twice in level 1, or Output IOH X'07' failed twice in level 1 	NCP re-IPL	NO	40
9B	0	IN CA X'08' failed in level 1	NCP retry	NO	NO
9B	0	IN CA X'08' failed in level 1 (limit threshold)		NO	NO
9C	0920	IOH failed in level 1, abort ADP recovery	NCP re-IPL	NO	NO
9D	0	CA microcode detected error <ul style="list-style-type: none"> X'0D' bit 0.1 ON Origin found in X'60' 	CA down	51	51
9E	0	Unresolved error on CA level 1 <ul style="list-style-type: none"> CA register X'0D' did not specify any adapter error bit See Specific Mechanism, page 11-12 	NCP retry	NO	NO
9E	0	Unresolved error on CA level 1 (limit threshold)	CA down	50	50
9E		Unresolved error on CA level 1 (last CA, no INN) All CAs have been disabled	NCP re-IPL	NO	NO
9F	0925	ESC interrupt (PEP/NEO are not CA owner) <ul style="list-style-type: none"> X'0F' bits 0.2 or 0.3 ON ESC address in X'3' byte 0 	NCP re-IPL	NO	NO
B1	0	Unresolved CA level 3 <ul style="list-style-type: none"> Initial select interrupt (X'0F' bit 0.2), but no bit ON in X'00'. See Specific Mechanism, page 11-12 	NCP retry	NO	NO
B1	091C	Unresolved CA level 3 initial select interrupt (limit threshold)	NCP re-IPL	NO	NO
B2	0	Unresolved CA level 3 <ul style="list-style-type: none"> Data/status interrupt (X'0F' bit 0.3), but no bit ON in X'02', and it is not a system reset (no bit in X'00'). 	NCP retry	NO	NO
B2	091D	Unresolved CA level 3 data/status interrupt (limit threshold)	NCP re-IPL	NO	NO
B3	0	Unresolved CA level 3 interrupt <ul style="list-style-type: none"> Level 3 but no initial select nor data status 	NCP retry	NO	NO
B3	091E	Unresolved CA level 3 interrupt (limit threshold)	NCP re-IPL	NO	NO

CA BER

BER ID	Abend Code (NCP)	Event Description	Recovery or PGM Action	ALERT	ALARM
B5	0927	NCP cannot disable CA after an error detected on the CA. NCP exhausted disable count	NCP re-IPL	NO	NO
B6	0	Inappropriate command (neither NOP nor TIO) on stacked initial status: PEP only (X'00' bit 0.5)	NCP retry	NO	NO
B6	0926	Inappropriate command (neither NOP nor TIO) on stacked initial status (limit threshold)	NCP re-IPL	NO	NO
B7	091E	CA level 3 interrupt from an undefined CA <ul style="list-style-type: none"> • CA installed and attached but not defined in NCP • CA installed and attached but the box is defined as link-attached 	NCP re-IPL	NO	NO
B8	091E	CA level 3 interrupt from a CA that is neither installed nor attached to that CCU	NCP re-IPL	NO	NO
B9	0	Channel media device level error	NCP retry	NO	NO
BA	091E	CA level 3 interrupt but the CA is not operational	NCP re-IPL	NO	NO
BB		CA level 3 from a CA that is CACM disconnect (MOSS cancel CACM and reset CA)		NO	NO
BC		CA level 3 from a CA with install in progress (MOSS cancel CACM and reset CA)		NO	NO
BD	091E	CA level 3 from a CA ERP inoperative	NCP re-IPL	NO	NO
BE	091E	CA level 3 from a disabled CA	NCP re-IPL	NO	NO
BF	0	Unresolved adapter level 1 interrupt (CA reg X'0E' did not specify a CA with the level 1 interrupt)	NCP retry	NO	NO
BF	0919	Unresolved adapter level 1 interrupt (limit threshold)	NCP re-IPL	NO	NO

Note: In case of abend, NCP re-IPL is performed and the Alarm/Alert is generated when IPL is completed. Alert is triggered by MOSS BER ID 06, error code 05.

CA BER Type 10 (Detailed BER Display)

CA BER Type 10 - IDs 18, 1C, 1E, 80, 97, 9B: Format foC1, see page 11-176. Program level 1 generates one of the following BERs when an error occurs during a PIO operation on a channel.

```

                                ELD DETAIL
SEL#:hhhh  FLAG:hh DATE:dd/dd TIME:dd:dd TYPE:10 ID:hh <LOST:ddd CP-ABEND:hhhh>
<ERROR DESCRIPTION>                                <REFER.CODE IN CHAR.> CCCCCC
F:bbbbbbbb CAVT:bbbbbbbb X75:hhhh
X7E:hhhh X76:hhhh I:hhhh LAR:hhhhhhhh X76U:hhhh ETA:hhhh ADNO:hh
SWA:hhhh IAR:hhhhhh TA:hhhh TD:hhhh X8:hhhh X9:hhhh  XA:hhhh
X50:hhhh X51:hhhh X52:hhhh
CAB:hhhh hhhh hhhh hhhh hhhh hhhh hhhh hhhh hhhh hhhh hhhh hhhh
      hhhh hhhh hhhh hhhh hhhh hhhh hhhh hhhh hhhh hhhh hhhh
CAC:hhhh
X0:hhhh X1:hhhh X2:hhhh X3:hhhh X4:hhhh X5:hhhh X6:hhhh X7:hhhh
XB:hhhh XC:hhhh XD:hhhh XE:hhhh XF:hhhh

====>

F1:END F2:MENU2 F3:ALARM F4:SUMMARY F5:LIST F7:PREVIOUS F8:NEXT

```

CA BER Type 10 - IDs 14, 16, 91, 9A: Format foC2, see page 11-176. Program level 1 generates one of the following BERs when an error occurs during an AIO operation with a channel.

```

                                ELD DETAIL
SEL#:hhhh  FLAG:hh DATE:dd/dd TIME:dd:dd TYPE:10 ID:hh<LOST:ddd CP-ABEND:hhhh>
<ERROR DESCRIPTION>                                <REFER.CODE IN CHAR.> CCCCCC
F:bbbbbbbb
X7E:hhhh X76:hhhh X75:hhhh ETA:hhhh X76U:hhhh FPR:hhhhhhhh SWA:hhhh
X50:hhhh X51:hhhh X52:hhhh
CAB:hhhh hhhh hhhh hhhh hhhh hhhh hhhh hhhh hhhh hhhh hhhh hhhh
      hhhh hhhh hhhh hhhh hhhh hhhh hhhh hhhh hhhh hhhh hhhh
CAC:hhhh
X0:hhhh X1:hhhh X2:hhhh X3:hhhh X4:hhhh X5:hhhh X6:hhhh X7: hhhh
XB:hhhh XC:hhhh XD:hhhh XE:hhhh XF:hhhh

====>

F1:END F2:MENU2 F3:ALARM F4:SUMMARY F5:LIST F7:PREVIOUS F8:NEXT

```

CA BER Type 10 IDs 10, 1B, 1F, 87, 90, 92, 93, 94, 96, 98, 99, 9C, 9D, 9E, 9F

Format foC3, see page 11-177. Program level 1 generates one of these BERs when a CA reports an error on its level 1.

```

                                ELD DETAIL
SEL#:hhhh  FLAG:hh DATE:dd/dd TIME:dd:dd TYPE:10 ID:hh<LOST:ddd CP-ABEND:hhhh>
<ERROR DESCRIPTION>                                <REFER.CODE IN CHAR.> CCCCCCCC
F:bbbbbbbb
X7E:hhhh  X76:hhhh  ADNO:hh  LAR:hhhhhhhh  X76U:hhhh  TA:hhhh  SWA :hhhh
X60:hhhh  X50:hhhh  X51:hhhh  X52:hhhh
CAB:hhhhhhhh hhhhhhhh hhhhhhhh hhhhhhhh hhhhhhhh hhhhhhhh
      hhhhhhhh hhhhhhhh hhhhhhhh hhhhhhhh hhhhhhhh hhhhhhhh CAC:hhhh
X0:hhhh  X1:hhhh  X2:hhhh  X3:hhhh  X4:hhhh  X5:hhhh  X6:hhhh  X7: hhhh
XB:hhhh  XC:hhhh  XD:hhhh  XE:hhhh  XF:hhhh

===>

F1:END F2:MENU2 F3:ALARM F4:SUMMARY F5:LIST F7:PREVIOUS F8:NEXT

```

CA BER Type 10 - IDs 34, 35, B1, B2, B5, B6, BD, BE: Format foC4, see page 11-177. Program level 3 generates one of the following BERs when a CA request at level 3 remains unresolved.

```

                                ELD DETAIL
SEL#:hhhh  FLAG:hh DATE:dd/dd TIME:dd:dd TYPE:10 ID:hh<LOST:ddd CP-ABEND:hhhh>
<ERROR DESCRIPTION>                                <REFER.CODE IN CHAR.> CCCCCCCC
CAVT:bbbbbbbb
X77:hhhh  X7F:hhhh  X0:hhhh  X1:hhhh  X2:hhhh  X3:hhhh  X4:hhhh  X5:hhhh
X6:hhhh  X7:hhhh  XB:hhhh  XC:hhhh  XF:hhhh
CAB:hhhhhhhh hhhhhhhh hhhhhhhh hhhhhhhh hhhhhhhh hhhhhhhh
      hhhhhhhh hhhhhhhh hhhhhhhh hhhhhhhh hhhhhhhh hhhhhhhh
CAC:hhhh  TA:hh

===>

F1:END F2:MENU2 F3:ALARM F4:SUMMARY F5:LIST F7:PREVIOUS F8:NEXT

```

When the registers are set to 'FF', the information they contain is not valid.

CA BER Type 10 - IDs 81, 82, 83, 84: Format foC5, see page 11-177. Program level 3 generates one of the following BERs when a CA request at level 3 remains unresolved.

```

                                ELD DETAIL
SEL#:hhhh  FLAG:hh DATE:dd/dd TIME:dd:dd TYPE:10 ID:hh<LOST:ddd CP-ABEND:hhhh>
<ERROR DESCRIPTION>                                <REFER.CODE IN CHAR.> CCCCCCCC
F:bbbbbbbb CAVT:bbbbbbbb STAT:hhhh
X7E:hhhh X76:hhhh I:hhhh LAR:hhhhhhhhh X75:hhhh X76U:hhhh ETA:hhhhhhhh
ADNO:hh
SWA:hhhh IAR:hhhhhh TA:hhhh TD:hhhh X8:hhhh XE:hhhh XF:hhhh
FPR:hhhhhhhh
CAB:hhhh hhhh hhhh hhhh hhhh hhhh hhhh hhhh hhhh hhhh hhhh hhhh hhhh
      hhhh hhhh hhhh hhhh hhhh hhhh hhhh hhhh hhhh hhhh hhhh hhhh
====>

F1:END F2:MENU2 F3:ALARM F4:SUMMARY F5:LIST F7:PREVIOUS F8:NEXT

```

CA BER Type 10 - IDs 85, 86, 88, 89, BF: Format foC8, see page 11-178. Program level 3 generates one of the following BERs when a CA request at level 3 remains unresolved.

```

                                ELD DETAIL
SEL#:hhhh  FLAG:hh DATE:dd/dd TIME:dd:dd TYPE:10 ID:hh<LOST:ddd CP-ABEND:hhhh>
<ERROR DESCRIPTION>                                <REFER.CODE IN CHAR.> CCCCCCCC
F:bbbbbbbb
X7E:hhhh X76:hhhh ADNO:hh LAR:hhhhhhhhh X76U:hhhh TA:hhhh SWA :hhhh
XD:hhhh XE:hhhh XF:hhhh
CAVT:bbbbbbbb CCU-INPUT-X57:hhhh CCU-OUTPUT-X57:hhhh
====>

F1:END F2:MENU2 F3:ALARM F4:SUMMARY F5:LIST F7:PREVIOUS F8:NEXT

```

CA BER Type 10 - IDs B3, B7, B8, BA, BB, BC, BF: Format foC6, see page 11-177. Program level 3 generates one of the following BERs when a CA request at level 3 remains unresolved.

```

                                ELD DETAIL
SEL#:hhhh  FLAG:hh DATE:dd/dd TIME:dd:dd TYPE:10 ID:hh<LOST:ddd CP-ABEND:hhhh>
<ERROR DESCRIPTION>                                <REFER.CODE IN CHAR.> CCCCCCCC
CAVT:bbbbbbbb
X77:hhhh X7F:hhhh
TA:hhhh STATUS:hhhh CCU=INPUT-X57:hhhh CCU-OUTPUT-X57:hhhh XF:hhhh
====>

F1:END F2:MENU2 F3:ALARM F4:SUMMARY F5:LIST F7:PREVIOUS F8:NEXT

```

CA BER Type 10 - ID B9: Format foC7, see page 11-178. Program level 3 generates the following BER for a CA condition.

```
                                ELD DETAIL
SEL#:hhhh  FLAG:hh DATE:dd/dd TIME:dd:dd TYPE:10 ID:hh<LOST:ddd CP-ABEND:hhhh>
<ERROR DESCRIPTION>                                <REFER.CODE IN CHAR.> CCCCCCCC
CAVT:bbbbbbbb
X77:hhhh X7F:hhhh TA:hh STATUS:hhhh X0:hhhh X2:hhhh XF:hhhh X6:hhhh
CMD:hh CABSENSE:hh SENSE 1:hh SENSE 2:hh
ABORT REASON:hh DATA REASON:hh CMD REJ REASON:hh

===>

F1:END F2:MENU2 F3:ALARM F4:SUMMARY F5:LIST F7:PREVIOUS F8:NEXT
```

CA BER Type 10 - Field Description

Field Name	Meaning	Refer to
ABORT REASON ADNO	CAB abort reason <ul style="list-style-type: none"> field ADNO for PIO operation field XE for CA error reported at level 1 field X75 for AIO operation field XF for CA error reported at level 3. 	page 11-175
CAB	CA address (1 to 16) as used by NCP/PEP in its control blocks (not to be confused with ESC or NSC address). X'30' bytes of fields from the CAB, from CABCOND up to and including CABXR6F. For PEP the fields CASEL through TERMADR are included from the PEP CHCB (X'10' bytes). The remaining space is padded with X'FF' for PEP.	(*)
CABSENSE	CA sense byte	page 11-174
CAC	Channel adapter contact control flags.	(*)
CAVT	CAVT flag	(*)
CCU INPUT X57	X'57' - Input CA command LS reg (same for output).	page 11-96
CMD	Current channel command	page 11-174
CMD REJ REASON	Command reject raison code	page 11-175
DATA REASON	Data check raison code	page 11-175
ETA	TA field of IOH failure in level 1.	(*)
F	Indicator flag byte (indicates a byte expansion follows)	(*)
I	First two bytes of instruction.	
IAR	IAR of interrupt level.	page 2-42
LAR	Lagging Address Register (X'74').	page 2-42
SENSE 1	Extended sense byte 1	page 11-174
SENSE 2	Extended sense byte 2	Unused
STAT	CA Reg X'9' Autoselection chain status.	(*)
STATUS	CER channel adapter state.	page 11-174
SWA	Switch adapter error register.	Unused
TA	IOHI image -- TA data registers X'50', X'70'. (TA: hhhh means data bytes 0 and 1).	page 3-33
TD	IOHI image -- TD data adapter specific bytes (TD: hhhh means data bytes 0 and 1).	page 3-33
X0-XF	Channel Adapter Registers	Channel 7
X3M and X6M	CA cycle steal fixed pointer register.	page 2-21
X50	X'50' - Adapter bus control module check register	(*)
X51	X'51' - Channel A control module check register	(*)
X52	X'52' - Channel B control module check register	(*)
X60	X'60' - Microcode-detected error code register	(*)
X7E	X'7E' - CCU level 1 interrupt.	page 2-40
X7F	X'7F' - Interrupt request reg - CCU level 2, 3, and 4.	page 2-42
X74	X'74' - Cycle steal control word register.	page 2-30
X75	X'75' - LAR bytes (see CAn).	page 2-31
X76	X'76' - IOC error summary register.	page 2-34
X76U	X'76' - Cause of error not found (PIO to read error register failed).	page 2-34
X77	X'77' - Interrupt request reg - adapter levels 2 and 3.	page 2-36
X79	X'79' - Utility.	page 2-37

(*) For software information on BERs originated by NCP/PEP, refer to the associated product documentation.

CA BER Type 10 - Field Details

<i>Table 11-60 (Page 1 of 2). MOSS BER Type 10 ID B9 Field Details</i>		
Field Name	Bit pattern or Hex value	Meaning
CMD	01	Current channel command
	02	Write
	03	Read
	04	No op
	05	Sense
	09	Write IPL control
	31	Write break
	32	Write start 0
	51	Read start 0
	52	Write start 1
	61	Read start 1
	62	Write XID control
	72	Read XID control
	93	Read configuration data
	A3	Restart reset
C3	Discontact control	
E4	Contact control	
		Sense ID
STATUS	8000	CER channel adapter state
	4000	Attention
	2000	Status modifier
	1000	Control unit end
	0800	Busy
	0400	Channel end
	0200	Device end
	0100	Unit check
		Unit exception
CABSENSE	1	CA sense byte
	. 1	Command reject
	. . 1	Intervention required
	. . . 1	Bus out check
 1	Equipment check
 1	Data check
 1	Overrun
 1	Not initialized
. 1	Program abort	
SENSE 1	1	Extended sense byte 1
	. 1	Dump complete
	. . 1	Imprecise data check
	. . . 1	Resetting event
		Device characteristics change

Field Name	Bit pattern or Hex value	Meaning
ABORT REASON	01 02 03 04 10 11 12 13 30 31 32 33 34 35 36 37 38 39 3A 40 41 42 43 44 45 46 47 50 51 60 61	CAB abort reason codes Initialized state. Not defined as CA line Initialized state. EP only line Initialized and concacted state CA line Initialized and concacted state CA line FID4 concacted state FID2 concacted state Contact pending state Contact pending state Discontacted or ANS in progress Write start received during XID exchange XID proc failed to complete within ATO limit Read start received during XID exchange Read XID received out of sequence Unexpected contact channel Cmd received Contact channel Cmd received out of sequence Discontact channel Cmd received PRI received and ANS invoked XID received on channel link Station on channel link in contact/discontact state Inbound transfer while ANS in progress Bus out check W/ANS in progress Equipment check W/ANS in progress Inbound transfer data streaming timeout Inbound transfer W/ANS in progress Channel stop or HIO received during read Cmd Inbound transfer data streaming timeout XID NEG. failed, ANS invoqued XID3 received W/length error XID3 received W/CV22 appened PIU received while not FID4 contacted PIU received while not FID2 contacted
DATA REASON	01 02 03 04 05 06 07 08 0A 0B	Data check reason code Unrecognizable XID Type Received XID2 length incorrect PIU can not be routed to INN path control PIU can not be routed to BNN path control Transfer count exceeded LH validation failed Set blocking delay LH length invalid Invalid LH function code Input data buffer was empty Channel stop occurred
CMD REJ REASON	01 02 03 04	Command reject reason code Channel Cmd Decoder did not recognize the Cmd code as valid MOSS failed to acknowledge write IPL Cmd in time to avoid equipemnt check Incorrect XID channel Cmd sequence unexpected read XID RCD command received over an invalid type of CA

CA BER Type 10 - Formats

Format f0C1		Format foC2	
IDs: 18, 1C, 1E, 80, 97, 9B		IDs 14, 16, 91, 9A	
Bytes	Meaning	Bytes	Meaning
1-27	Header	1-27	Header
28-29	TYPE-ID	28-29	TYPE-ID
30	LOST	30	LOST
31-32	Abend	31-32	Abend
33-34	X7E	33-34	X7E
35-36	X76	35-36	X76
37-38	I	37-38	X75
39-42	LAR	39-40	Unused
43-44	X75	41-42	ETA
45-46	X76U	43-44	Unused
47-48	ETA	45-46	X76U
49	Unused	47-50	FPR
50	Adno	51	Flag
51	Flag	52	Unused
52	CAVT	53-54	SWA
53-54	SWA error register	55-68	Unused
55	Unused	69-70	X50 (*)
56-58	IAR int level	71-72	X51 (*)
59-60	TA	73-74	X52 (*)
61-62	TD	75-122	CAB (*)
63-68	Unused	123-124	CAC (*)
63-64	X8	125-150	CA regs X'0'-X'F'
65-66	X9		(*)
67-68	XA		
69-70	X50 (*)		
71-72	X51 (*)		
73-74	X52 (*)		
75-122	CAB (*)		
123-124	(CAC)		
125-150	CA Regs X'0'-X'F'		

(*) means that if contents are FEF EFE...FE, data is invalid.

Figure 11-22 (Part 1 of 3). CA BER Formats

Format foC3		Format foC4	
IDs: 10 1B 1F 87 90 92 93 94 96 98 99 9C 9D 9E 9F		IDs: 34 35 B1 B2 B5 B6 BD BE	
Bytes	Meaning	Bytes	Meaning
1-27	Header	1-27	Header
28-29	TYPE-ID	28-29	TYPE-ID
30	LOST	30	LOST
31-32	Abend	31-32	Abend
33-34	X7E	33-34	X77
35-36	X76	35-36	X7F
37	ADNO	37-38	X0
38	Unused	39-40	X1
39-42	LAR	41-42	X2
43-44	Unused	43-44	X3
45-46	X76U	45-46	X4
47-48	TA	47-48	X5
49-50	Unused	49-50	X6
51	Flag	51-52	X7
52	Unused	53-54	XB
53-54	SWA	55-56	XC
55-68	Unused	57-58	XF
67-68	X60 ID=9D/1F	59-106	CAB/CHCB
69-70	X50 (*)	107-108	CAC
71-72	X51 (*)	109	TA
73-74	X52 (*)	110	Unused (F for B5)
75-76	N/A	111	Flag
77-124	CAB (*)		
125-126	CAC		
127-152	CA Regs X'0'-X'F'		

(*) means that if contents are FEF EFE...FE, data is invalid.

Figure 11-22 (Part 2 of 3). CA BER Formats

Format f0C5	
IDs: 81 to 84	
Bytes	Meaning
1-27	Header
28-29	TYPE-ID
30	LOST
31-32	Abend
33-34	X7E
35-36	X76
37-38	I 0 for IDs 81/82
39-42	LAR
43-44	X75 0 for IDs 83/84
45-46	X76U
47-48	ETA
49	Unused
50	ADNO
51	Flag
52	CAVT
53-54	SWA
56-58	IAR 0 for IDs 81/82
59-60	TA
61-62	TD
Only for IDs 81,83 (0 for 82,84)	
63-64	X'08'
65-66	STAT
67-68	X'0E'
69-70	X'0F'
71-74	FPR
75-122	CAB

Format foC6	
IDs: B3 B7 B8 BA BB BC	
Bytes	Meaning
1-27	Header
28-29	TYPE-ID
30	LOST
31-32	Abend
33-34	X77
35-36	X7F
37-38	STATUS
39-40	CCU-INPUT X57
41-42	CCU-OUTPUT X57
43	TA
44	CAVT
45-46	X0F

Format foC7	
IDs: B9	
Bytes	Meaning
1-27	Header
28-29	TYPE-ID
30	LOST
31-32	Abend
33-34	X77
35-36	X7F
37-38	STATUS
39-40	X00
41-42	X02
43	TA
44	CAVT
45-46	X0F
47-48	X06
49	Command
50	CABSENSE
51	SENSE1
52	SENSE2
53	Abort reason
54	Data check reason
55	CMD reject reason
56	Equip check reason

Format foC8	
IDs: 85 86 88 89 BF	
Bytes	Meaning
1-27	Header
28-29	TYPE-ID
30	LOST
31-32	Abend
33-34	X7E
35-36	X76
37	ADNO
38	CAVT
39-42	LAR
43-44	TA
45-46	76U
47	F
48	Unused
49-50	SWA
51-52	CCU-INPUT X57
53-54	CCU-OUTPUT X57
55-60	CA Reg XD to XF

Figure 11-22 (Part 3 of 3). CA BER Formats

NCP TSS/HPTSS BER Type 11

TSS/HPTSS BER Type 11 - Summary

<i>Table 11-61 (Page 1 of 5). TSS/HPTSS BER Type 11 Summary</i>					
BER ID	ABEND Code (NCP)	Event Description	Recovery or PGM Action	ALERT	ALARM
14	0930	HSSyy AIO Address Exception Check IOC error LVL1 with: LVL1 summary register X7E = '0100' (IOC-1) with IOC LVL1 register X76 = '8200' (IOC-1)	NCP re-IPL	NO	NO
16	0931	HSSyy AIO Storage Protect Check IOC Error LVL1 with: LVL1 Summary Register X7E = '0100' (IOC-1) with IOC LVL1 Register X76 = '4200' (IOC-1)	NCP re-IPL	NO	NO
18	0	HSSyy IOH/IOHI to Adapter not attached IOC Error LVL1 with: LVL1 Summary Register X7E = '0100' (IOC-1) with IOC LVL1 Register X76 = '2800' (IOC-1) For adapter address in TA, the CDS shows the adapter not attached.		NO	NO
1B	0933	HSSyy Invalid Input IOH IOC Error LVL1 with: LVL1 Summary Register X7E = '0100' (IOC-1) with IOC LVL1 Register X76 = '5800' (IOC-1) LAS (line adapter status) bit 1.7 is On. Origin given in error status type 1 of CSP, bit 1.7 ON	NCP re-IPL	NO	NO
1C	0	Line command reject Error status type 3 of CSP, bit 1.0 = 1	Line down	43	43
1E	0	HSSyy Invalid Output IOH to Adapter Adapter LVL1 with: LVL1 Summary Register X7E = '2000' (IOC-1) with Adapter Status Register (Error Status Type 3 non- Hardstop) or LAS = B'1000 000u 0100 0000' as Invalid Output IOH for which the related PIO terminated correctly (no IOC error LVL1) but the adapter microcode rejects the Output IOH by raising this current adapter LVL1. 'u' = '1' means adapter disconnected due to NCP command 'F2'.	LSS/HSS down	60	60
1E	0	Scanner disconnected due to 'F2' command sent by NCP. <ul style="list-style-type: none"> • X'7E' bit 0.2 or 0.6 ON • Error status type 3 of CSP = X'8140' 	LSS/HSS down	60	60
26		HSSyy Portx SCTL/DMA Storage Protect or Address Exception Adapter LVL2 with: PSA LCS (Line Control Status) = 'DC' as any DMA type error PSA HELCS (High byte of Extended LCS) = '10' as specifically SP/AE	Line down HSS down	73	73

<i>Table 11-61 (Page 2 of 5). TSS/HPTSS BER Type 11 Summary</i>					
BER ID	ABEND Code (NCP)	Event Description	Recovery or PGM Action	ALERT	ALARM
91	0	HSSy AIO Error IOC Error LVL1 with: LVL1 Summary Register X7E = '0100' (IOC-1) with IOC LVL1 Register X76 = 'uV00' (IOC-1) with AIO CCW Register X75H or X75L = B'1nnn n000' where nnnn from 0 to 15 represents the IOC relative adapter number, adapter which was performing the AIO, AIO (Adapter Initiated Operation / Cycle Steal) failing in Time-Out (V='A') or in Bus-In parity Check (V='6') with 'u' giving the time when the opera- tion failed (refer to page 2-34).	TSS μ code retry	63	63
92	0	HSSy Unresolved AIO Error IOC Error LVL1 with: LVL1 Summary Register X7E = '0100' (IOC-1) with IOC LVL1 Register X76 = 'uV00' (IOC-1) with AIO CCW Register X75H or X75L = B'1nnn n000' where nnnn from 0 to 15 represents the IOC relative adapter number, adapter which was performing the AIO, but as opposed to previous BER 11 91, V='2' only (not 'A' or '6').	TSS μ code retry	NO	NO
92	0	Scanner AIO error unresolved (limit threshold)	LSS/HSS down	63	63
93	0	HSSy AIO Invalid CSCW IOC Error LVL1 with: LVL1 Summary Register X7E = '0100' (IOC-1) with IOC LVL1 Register X76 = '2200' (IOC-1) AIO CCW register X75H or X75L = B'1nnn n000' where nnnn from 0 to 15 represents the IOC relative adapter number, adapter which was performing the AIO.	TSS μ code retry	NO	NO
93	0	Scanner AIO invalid CSCW (limit threshold)	LSS/HSS down	63	63
94		HSSy Portx Cycle Steal Error on Set Mode Adapter LVL1 with: LVL1 Summary Register X7E = '2000' (IOC-1) Adapter Status Register (Error Status Type 3 non- Hardstop) or LAS = B'1000 0000 10xx xxxz' (almost identical to BER 11 1C as Command Reject on line interface address 'xxxxxz') but NCP looks at the SLI bit in the LNVT: if ON (Set LNVT Initial required) and if adapter command-reject status = '10xx xxxx xxxx xxxz' then NCP will generate this BER 11 94 instead of BER 11 1C.		43	43
95	0	HSSy Adapter LVL1 Hardcheck Adapter LVL1 with: LVL1 Summary Register X7E = '2000' (IOC-1) with Adapter Status Register (Error Status Type 3 Hardstop) or LAS = B'0000 0uuu uuuu uu00' where the string 'uu..uu' reflects the hardware checkers which have been raised (u=1), as several can occur simultaneously in some cases of failure.	LSS/HSS down	63	63

<i>Table 11-61 (Page 3 of 5). TSS/HPTSS BER Type 11 Summary</i>					
BER ID	ABEND Code (NCP)	Event Description	Recovery or PGM Action	ALERT	ALARM
96	0	HSSyy Adapter Disconnected by operator Adapter LVL1 with: LVL1 Summary Register X7E = '2000' (IOC-1) with Adapter Status Register (Error Status Type 3 non-Hardstop) or LAS = B'1000 0001 0000 0000', meaning "adapter put in disconnect mode" on MOSS operator's request.	Scanner OFF line	B8, BA	B8, BA
97	0	HSSyy PIO Error IOC Error LVL1 with: LVL1 Summary Register X7E = '0100' (IOC-1) with IOC LVL1 Register X76 = 'uV00' (IOC-1) as PIO (Program Initiated Operation) failing in Time-Out (V=8) or in Bus-In parity Check (V=4) with 'u' giving the time when the operation failed (refer to page 2-34).	NCP retry	NO	NO
97	0	Scanner PIO error-output IOH/IOHI before threshold. BER file adapter status = Error status type 1 of CSP.	LSS/HSS down	63	63
98	0	Scanner PIO error-output IOH/IOHI (limit threshold) BER file adapter status = Error status type 1 of CSP.	LSS/HSS down	63	63
99	0	HSSyy Adapter LVL1 non-Hardcheck Adapter LVL1 with: LVL1 Summary Register X7E = '2000' (IOC-1) with Adapter Status Register (Error Status Type 3 non-Hardstop) or LAS = B'1iii 0uu0 0000 000v' where 'iii' (invalid interrupt level from 0 to 7) and 'u' are checkers raised by Mcode and 'v' by hardware.	LSS/HSS down	63	63
9A	0	Scanner adapter error unresolved • First get error status failed but retry was succesful. • Error status has value at time of failure.	NCP retry	NO	NO
9B	0	Interrupt from disconnected scanner Level 1 interrupt presented to NCP/PEP while the scanner is disconnected (X'01' bit 5 ON). X'7E' bit 0.2 or 0.6 ON		NO	NO
9B	093A	Interrupt from disconnected scanner (limit threshold)	NCP re-IPL	NO	NO
9C	0	Adapter PIO error on broadcast "get line ID" IOH command Adapter was the answering one at failure time.	None	NO	NO
9C	0	Adapter PIO error on broadcast "get line ID" IOH command Adapter was the answering one at failure time. (threshold)	Adapter down	63	63
9D	0	Scanner microcode error. BER file adapter status = status M is an error code for PE only.	LSS/HSS down	63	63
9E	0	Get error status command failed (IOC error) during NCP LVL1 process either ON Line Adapter LVL1 or on PIO Get Line ID error.		NO	NO
A1	0	Unresolved level 2 interrupt. If spurious retry count (the interrupt occurred on a non-defined line)		NO	NO
A1	0936	Unresolved level 2 interrupt (limit threshold) See Specific Mechanism, page 11-12	NCP re-IPL	NO	NO

TSS/HPTSS BER

<i>Table 11-61 (Page 4 of 5). TSS/HPTSS BER Type 11 Summary</i>					
BER ID	ABEND Code (NCP)	Event Description	Recovery or PGM Action	ALERT	ALARM
A2	0	Internal FESL error reported via level 2 <ul style="list-style-type: none"> • X'77' bit 0.1 ON • LCS = C0, C2, C4, C6, C8, D0, D2, D4, D6, D8 	Line down	43	43
A2	0	Internal FESH error reported via level 2 <ul style="list-style-type: none"> • X'77' bit 0.1 ON • LCS = C0, C2, C4, C6, C8, D0, D2, D4, or D8 	Line down	43	43
A2	0	Internal FESH error reported via level 2 <ul style="list-style-type: none"> • X'77' bit 0.1 ON • LCS = CE. Local clock failure. 	Line down	43	43
A3	0	Internal MUX error reported via level 2 <ul style="list-style-type: none"> • X'77' bit 0.1 ON • LCS = CA 	Line down	43	43
A3	0	Internal MUX/LIC error reported via level 2 <ul style="list-style-type: none"> • X'77' bit 0.1 ON (limit threshold) • LCS = CC. 	Line down	43	43
A3	0	Internal LIC error reported via level 2 <ul style="list-style-type: none"> • X'77' bit 0.1 ON • LIC failing or not plugged. • LCS = CE. 	Line down	43	43
A3	0	Internal LIC error reported via level 2 <ul style="list-style-type: none"> • X'77' bit 0.1 ON • Line cannot be accessed by configuration. • LCS = DE. 	Line down	43	43
A3	0	Internal FESH error reported via level 2 <ul style="list-style-type: none"> • X'77' bit 0.1 ON • Line not accessible, a line is already active LCS = 'DE' 	Line down	43	43
A4	0	Time out on any command, except F5. F5 command sent to the scanner, back up timer in NCP/PEP level 3 expired before receiving level 2 from scanner to process it.	Line down	NO	NO
A4	0	Transient FESL error reported at level 2, ELCS bit 7 ON	TSS μ code retry	NO	NO
A5	0	Transient MUX/LIC error reported at level 2, ELCS bit 7 OFF	TSS μ code retry	NO	NO
A6	0	SCTL/DMA internal error, or BU LCS = 'DC' <ul style="list-style-type: none"> • ELCS bits 4,5,6 = 001 	Line down	73	73
A6	0	SCTL/DMA internal error <ul style="list-style-type: none"> • LCS = 'DC' • ELCS bits 4,5,6 = 001 	Line down	73	73
A7	0	SCTL/DMA interface (main bus) error <ul style="list-style-type: none"> • LCS = 'DC' • ELCS bits 4,5,6 = 010 	Line down	73	73
A8	0	DMA reported error <ul style="list-style-type: none"> • LCS = 'DC' • ELCS bits 4,5,6 = 011 	Line down	73	73

Table 11-61 (Page 5 of 5). TSS/HPTSS BER Type 11 Summary

BER ID	ABEND Code (NCP)	Event Description	Recovery or PGM Action	ALERT	ALARM
A9	0	DMA parity check or DMA time out <ul style="list-style-type: none"> • LCS = 'DC' • ELCS bits 4,5,6 = 100 	Line down	73	73
AA	0	FESH/DMA interface error <ul style="list-style-type: none"> • LCS = 'DC' • ELCS bits 4,5,6 = 101 	Line down	73	73
AB		Internal LIC error level 2 (LIC5 and LIC6)	Line down	43	43
B1	0	Scanner command time out on F5. Command F5 sent to the scanner, back up timer in NCP/PEP level 3 expired before receiving level 2 from scanner to process it.	Line down	43	43

Note: In case of abend, NCP re-IPL is performed and the Alarm/Alert is generated when IPL is completed. Alert is triggered by MOSS BER ID 06, error code 05.

TSS/HPTSS BER Type 11 (Detailed BER Display)

TSS/HPTSS BER Type 11 - ID 14, 16, 91, 92, 93: Format foT1, see page 11-189. Program level 1 generates one of the following BERs when an error occurs during an AIO operation on a scanner.

```

                                ELD DETAIL
SEL#:hhhh  FLAG:hh DATE:dd/dd TIME:dd:dd TYPE:11 ID:hh<LOST:ddd CP-ABEND:hhhh>
<ERROR DESCRIPTION>                                <REF. CODE IN CHAR.> CCCCCCCC

F:bbbbbbbb
X7E:hhhh  X76:hhhh  X75:hhhh  ETA:hhhh  LAS:hhhh  X76U:hhhh  SPR:hhhhhhhh
SWA:hhhh  LAR:hhhhhhhh

====>

F1:END F2:MENU2 F3:ALARM F4:SUMMARY F5:LIST F7:PREVIOUS F8:NEXT
    
```

TSS/HPTSS BER Type 11 - IDs 18, 1B, 97, 98, 9C, 9E: Format foT2, see page 11-189. Program level 1 generates one of these BERs when an error occurs during a PIO operation on a scanner.

```

                                ELD DETAIL
SEL#:hhhh  FLAG:hh DATE:dd/dd TIME:dd:dd TYPE:11 ID:hh<LOST:ddd CP-ABEND:hhhh>
<ERROR DESCRIPTION>                                <REF. CODE IN CHAR.> CCCCCCCC

F:bbbbbbbb X7E:hhhh X76:hhhh I:hhhh LAR:hhhhhhhh
LAS:hhhh  X76U:hhhh  ETA:hhhh  SWA:hhhh  IAR:hhhhhh  TA:hhhhh  TD:hhhh
IOB/LXB:hhhhhhhh hhhhhhhh hhhhhhhh hhhhhhhh hhhhhhhh
            hhhhhhhh hhhhhhhh hhhhhhhh hhhhhhhh
CCB:hhhhhhh hhhhhhhh hhhhhhhh hhhhhhhh hhhhhhhh hhhhhhhh hhhhhhhh hhhhhhhh
            hhhhhhhh hhhhhhhh hhhhhhhh hhhhhhhh hhhhhhhh hhhhhhhh hhhhhhhh
AXB:hhhhhhh hhhhhhhh hhhhhhhh hhhhhhhh hhhhhhhh hhhhhhhh hhhhhhhh hhhh  hh
SCB:hhhh  hhhh  hhhh  hhhh  hhhh  hhhh  hhhh  hhhh  hh
PSA:hhhh  hhhh  hhhh  hhhh  hhhh  hhhh  hhhh  hhhh  hhhh  hhhh  hhhh  hhhh

====>

F1:END F2:MENU2 F3:ALARM F4:SUMMARY F5:LIST F7:PREVIOUS F8:NEXT
    
```

TSS/HPTSS BER Type 11 - IDs 1E, 95, 96, 99, 9A, 9B, 9D: Format foT3, see page 11-189. Program level 1 generates one of these BERs when an error is reported by a scanner on level 1.

```

                                ELD DETAIL
SEL#:hhhh  FLAG:hh DATE:dd/dd TIME:dd:dd TYPE:11 ID:hh<LOST:ddd CP-ABEND:hhhh>
<ERROR DESCRIPTION>                                <REFER.CODE IN CHAR.> CCCCCCCC
F:bbbbbbbb
X7E:hhhh X76:hhhh ADNO:hh LAS:hhhh X76U:hhhh SWA:hhhh LAR:hhhhhhhh

====>

F1:END F2:MENU2 F3:ALARM F4:SUMMARY F5:LIST F7:PREVIOUS F8:NEXT

```

TSS/HPTSS BER Type 11 - ID A1: Format foT4, see page 11-190. These BERs are generated on a level 2 unresolved interrupt.

```

                                ELD DETAIL
SEL#:hhhh  FLAG:hh DATE:dd/dd TIME:dd:dd TYPE:11 ID:hh<LOST:ddd CP-ABEND:hhhh>
<Error description>                                <REFER.CODE IN CHAR.> CCCCCCCC
F:bbbbbbbb
TA:hh TD:hh NW:hhhh IDR:hhhh LNVT:hhhhhhhh LCS:hh
PSA:hhhh hhhh hhhh hhhh hhhh hhhh hhhh hhhh hhhh hhhh hhhh hhhh hhhh hhhh
CNT:hhhh

OVERRIDE FLAG WITH NEW HEXADECIMAL VALUE
====>

F1:END F2:MENU2 F3:ALARM F4:SUMMARY F5:LIST F7:PREVIOUS F8:NEXT

```

TSS/HPTSS BER Type 11 - ID B1: Format foT5, see page 11-190. These BERs are generated on a level 2 unresolved interrupt.

```

                                ELD DETAIL
SEL#:hhhh  FLAG:hh DATE:dd/dd TIME:dd:dd TYPE:11 ID:hh<LOST:ddd CP-ABEND:hhhh>
<Error description>                                <REFER.CODE IN CHAR.> CCCCCCCC
F:bbbbbbbb
TA:hh TD:hh NW:hhhh
PSA:hhhh hhhh hhhh hhhh hhhh hhhh hhhh hhhh hhhh hhhh hhhh hhhh hhhh hhhh

OVERRIDE FLAG WITH NEW HEXADECIMAL VALUE
====>

F1:END F2:MENU2 F3:ALARM F4:SUMMARY F5:LIST F7:PREVIOUS F8:NEXT

```

TSS/HPTSS BER Type 11 ID 26, A2, A3, A4, A5, A6, A7, A8, A9, AA, AB:
 Format foT5, see page 11-190. Program level 2 generates one of these BERs when a scanner internal error or a transient line error is detected.

```

                                ELD DETAIL
SEL#:hhhh  FLAG:hh DATE:dd/dd TIME:dd:dd TYPE:11 ID:hh<LOST:ddd CP-ABEND:hhhh>
<ERROR DESCRIPTION>                                <REFER.CODE IN CHAR.> CCCCCCCC
F:bbbbbbbb TA:hh TD:hh NW:hhhh IDR:hhhh
PSA:hhhh hhhh hhhh hhhh hhhh hhhh hhhh hhhh hhhh hhhh hhhh hhhh hhhh hhhh
IOB/LXB:hhhhhhhh hhhhhhhh hhhhhhhh hhhhhhhh hhhhhhhh hhhhhhhh hhhhhhhh
          hhhhhhhh hhhhhhhh hhhhhhhh hhhhhhhh
CCB:hhhhhhhh hhhhhhhh hhhhhhhh hhhhhhhh hhhhhhhh hhhhhhhh hhhhhhhh hhhhhhhh
          hhhhhhhh hhhhhhhh hhhhhhhh hhhhhhhh hhhhhhhh hhhhhhhh hhhhhhhh hhhhhhhh
AXB:hhhh hhhh hhhh hhhh hhhh hhhh hhhh
SAT:hhhh hhhh hhhh hhhh hhhh hhhh hhhh hhhh hh
SCB:hhhh hhhh hhhh hhhh hhhh hhhh hhhh hhhh hh
CSC:hhhh CNT:hhhh

===>

F1:END F2:MENU2 F3:ALARM F4:SUMMARY F5:LIST F7:PREVIOUS F8:NEXT
    
```

Note: Lost and CP abend fields are displayed when applicable.

TSS/HPTSS BER Type 11 ID 94, 1C: Format foT6, see page 11-190. Program level 1 generates this BER when a command reject is reported by a scanner on level 1 (control program error).

```

                                ELD DETAIL
SEL#:hhhh  FLAG:hh DATE:dd/dd TIME:dd:dd TYPE:11 ID:hh<LOST:ddd CP-ABEND:hhhh>
<ERROR DESCRIPTION>                                <REFER.CODE IN CHAR.> CCCCCCCC
F:bbbbbbbb LNVT:hhhh PSA:hhhh hhhh hhhh hhhh hhhh hhhh hhhh hhhh
SCF:hh LSTAT:hh LAS:hhhh CR1:hh CR2:hh IAR:hhhhhhhh TA:hh TD:hh
IOB/LXB:hhhhhhhh hhhhhhhh hhhhhhhh hhhhhhhh hhhhhhhh hhhhhhhh hhhhhhhh
          hhhhhhhh hhhhhhhh hhhhhhhh hhhhhhhh
CCB:hhhhhhhh hhhhhhhh hhhhhhhh hhhhhhhh hhhhhhhh hhhhhhhh hhhhhhhh hhhhhhhh
          hhhhhhhh hhhhhhhh hhhhhhhh hhhhhhhh hhhhhhhh hhhhhhhh hhhhhhhh hhhhhhhh
AXB:hhhhhhhh hhhhhhhh hhhhhhhh hhhhhhhh hhhhhhhh hhhhhhhh hhhhhhhh hhhh hh
SCB:hhhh hhhh hhhh hhhh hhhh hhhh hhhh hhhh hh

===>

F1:END F2:MENU2 F3:ALARM F4:SUMMARY F5:LIST F7:PREVIOUS F8:NEXT
    
```

TSS/HPTSS BER Type 11 - Field Description

<i>Table 11-62 (Page 1 of 2). TSS/HPTSS BER Type 11 Field Description</i>		
Field Name	Meaning	Refer to
ADNO	CS number (decimal) in error description field. This CS number is derived from: <ul style="list-style-type: none"> field TA for PIO operation <ul style="list-style-type: none"> for CS error reported at level 2 for CA error reported at level 3. field X75 for AIO operation. field CSPA for CS error reported at level 1. <p>If no n is specified (blank CS), problem isolation by program was not possible.</p>	
LAS or L-STAT	LA adapter status <ul style="list-style-type: none"> LA Error status type 1: CSP error status 1 LA Error status type 2: CSP error status 1 LA Error status type 3/H: CSP error status 1 	Chapter 4
CSPA	CSP address used by NCP/PEP (see CSn and LINEnn).	
ETA	TA field of IOH failure in level 1.	
IDR	Get line ID response.	Chapter 4
F	Indicator flag (indicates a byte expansion follows)	(*)
SWA	Unused	
CR1	First command sent to scanner	
CR2	Second command sent to scanner	
LAR	Lagging address register-	Page 2-42
SPR	LA shared pointer register X'3F' or X'6F'.	
CSC	Configuration status control flag (contains X'FFFF' for PEP, BSC/SS and BNN lines).	
CNT	Repetition count (BER flooding). Number of times the BER appeared.	
SCF	Secondary control field.	
I	First two bytes of instruction.	
IAR	IAR of interrupt level.	
LCS	Line control status.	Chapter 4 and page 5-31
LINEnn	Line number (0 to 31) within the CS (in error description line).	
LNVT	Line vector table.	Chapter 4
LOST	Lost record count (LRC).	(*)
NW	Network address (NCP) or CA number and ESC (PEP).	(*)
IOB/LXB	X'24' bytes of LXB (for SDLC lines) or IOB (for BSC/SS lines) control blocks. This area is padded with X'FF' for PEP.	(*)
CCB	X'40' bytes of data from the CCB control block. <ul style="list-style-type: none"> If PEP, the fields are CCBL2 through CCBPOLL inclusive. If PEP, the fields are CCBTROPT through CCBXPTR inclusive. 	(*)
AXB ACB TRACE	X'E' bytes of data from the AXB control block from AXBFTL through AXB+X'15' (ACB trace area). For PEP, this area contains the CCB extension starting at the PEP CCB + X'60'.	(*)
AXB PSA	X'11' bytes of data from the PSA trace area of the AXB control block (AXBASSCF through AXBTROFF). For PEP, this area contains the remaining portion of the CCB extension padded with X'F'.	(*)
SCB	X'19' bytes of the SCB/CUB from SCBSSCF (CUBSSCF) through SCBRTCNT (CUBRTCNT) inclusively. For BSC/SS lines and for PEP, this area is padded with X'FF's.	(*)

<i>Table 11-62 (Page 2 of 2). TSS/HPTSS BER Type 11 Field Description</i>		
Field Name	Meaning	Refer to
SAT	17 bytes of PSA trace area for NCP. For PEP, this area contains the EP CCB extension.	(*)
SCBCSCF	Configuration station control flags (NCP only).	(*)
PSA	Parameter area (16 bytes)-status area (12 bytes). The byte contents of the PSA depend on the current command (CCMD).	Chapter 4
TA	IOH/IOHI image -- TA data registers X'50', X'70' (TA: hh means TA data byte 0) (see CSn and LINEnn).	Chapter 4
TD	IOH/IOHI image -- TD data adapter specific bytes (TD: hh means TD data byte 1).	Chapter 4
X3F	CSP shared pointer register.	Page 2-26
X74	X'74' - LAR bytes (See CSn and LINEnn).	Page 2-26
X75	X'75' - Cycle steal control word register.	Page 2-26
X76	X'76' - IOC error summary register.	Page 2-26
X76U	X'76' - Cause of error not found (PIO to read error register failed).	Page 2-26
X77	X'77' - Interrupt request register adapter levels 2 and 3	Page 2-26
X79	X'79' - Interrupt level.	Page 2-26
X7E	X'7E' - CCU level 1 interrupt.	Page 2-26
X7F	X'7F' - Interrupt request register CCU levels 2, 3, and 4	Page 2-26

Note: All values are in hexadecimal notation (X'0' to X'F'), except for:

- Flag bytes F and CS STAT, which are in bit format (8 or 16 bits, 0 or 1)
- The error description line with a CS number and line number, which are in decimal notation.

(*) For software information on BERs originated by NCP/PEP, refer to the associated product documentation.

TSS/HPTSS BER Type 11 - Formats

Format: foT1		Format: foT2	
ID: 14 16 91 92 93		IDs: 18 1B 97 98 9C 9E	
Byte	Meaning	Byte	Meaning
1-27	Header	1-27	Header
28-29	TYPE-ID	28-29	TYPE-ID
30	LOST	30	LOST
31-32	Abend	31-32	Abend
33-34	X7E	33-34	X7E
35-36	X76	35-36	X76
37-38	X75	37-38	I
39-40	Unused	39-42	LAR
41-42	ETA	43-44	LAS
43-44	LAS	45-46	X76U
45-46	X76U	47-48	ETA
47-50	SPR	49-50	Unused
51	Flag	51	Flag
52	Unused	52	Unused
53-54	SWA	53-54	SWA
55-58	LAR	55	INTLVL
		56-58	IAR
		59-60	TA
		61-62	TD
		63-66	Unused
		67-102	IOB/LXB
		103-166	CCB
		167-198	AXB
		199-215	SCB
		216	Unused
		217-244	PSA

Figure 11-23 (Part 1 of 2). TSS/HPTSS BER Formats

Format: foT3

ID: 1E 95 96 99 9A 9B 9D	
Byte	Meaning
1-27	Header
28-29	TYPE-ID
30	LOST
31-32	Abend
33-34	X7E
35-36	X76
37	ADNO
38-42	Unused
43-44	LAS
45-46	X76U
47-50	Unused
51	F
52	TSS Flag
53-54	SWA
55-58	LAR
59-66	Unused
67-102	LBX
103-166	CCB
167-182	ATT
183-198	PSA Trace

Format: foT4

ID: A1	
Byte	Meaning
1-27	Header
28-29	TYPE-ID
30	LOST
31-32	Abend
33	F
34	Unused
35-36	IDR
37-64	PSA (56 = LCS)
65	TA byte 0
66	TD byte 1
67-68	NW
69-72	LNVT
73-108	IOB/LXB
109-172	CCB
173-186	AXB trace
187-203	SAT trace
204-219	SCB
220	SCBCSCF
221-222	Count

Format: foT5

IDs: 26 A2 A3 A4 A5 A6 A7 A8 A9 AA AB B1	
Byte	Meaning
1-27	Header
28-29	TYPE-ID
30	LOST
31-32	Abend
33	Flag
34	Unused
35-36	IDR
37-64	PSA
65	TA byte 0
66	TD byte 1
67-68	NW
69-104	IOB/LXB
105-168	CCB
169-182	AXB (IOB)
183-199	SAT trace
200-215	SCB
216	CSC
217-218	Count (Only for A2, A4, and AB)

Format: foT6

ID: 94 1C	
Byte	Meaning
1-27	Header
28-29	TYPE-ID
30	LOST
31-32	Abend
33	F
34	Interrupt level 1
35-36	LNVT
37-52	PSA
53	SCF
54	LSTAT
55-56	LAS
57	CR1
58	CR2
59-62	IAR
63-64	Unused
65	TA
66	TD
67-102	LXB/IOB
103-166	CCB
167-197	AXB
198	Unused
199-215	SCB
216	Unused

Figure 11-23 (Part 2 of 2). TSS/HPTSS BER Formats

NCP/PEP BER, Type 12

NCP/PEP BER Type 12 Summary

The following BERs are software errors detected by the CCU hardware. Software errors detected by software checking mechanisms (logical errors) lead to control program abends.

BER ID	Abend Code (NCP)	Event Description	Recovery or PGM Action	ALERT	ALARM
11	000A	IN/OUT or IOH/IOHI on level 5 IAR not 0, retry not possible.	NCP re-IPL	NO	NO
12	001B	Invalid operation code <ul style="list-style-type: none"> • X'7E' bit 0.4 ON 	NCP re-IPL	NO	NO
13	0950	Address exception - I fetch <ul style="list-style-type: none"> • X'7E' bit 1.1 ON 	NCP re-IPL	NO	NO
14	0951	Address exception - I execution <ul style="list-style-type: none"> • X'7E' bit 1.3 ON 	NCP re-IPL	NO	NO
15	0952	Storage protect - I fetch <ul style="list-style-type: none"> • IAR not 0 • X'7E' bit 1.2 ON 	NCP re-IPL	NO	NO
16	0953	Storage protect - I execution <ul style="list-style-type: none"> • X'7E' bit 1.4 ON 	NCP re-IPL	NO	NO
17	0954	Level 5 branch to storage location 0. IAR = 0.	NCP re-IPL	NO	NO
18	0955	User (non NCP code) branch to storage location 0. IAR = 0.	NCP re-IPL	NO	NO
19	000E	Logic error (interrupt reason lost). Program check in level 1.	NCP re-IPL	NO	NO
21	0	Level 2 PCI. The level 2 PCI should be OFF because level 1 has reset it (X'77' bit 0.7). If it is ON (hot level 2 PCI), or if spurious retry count from a PCI level 2 interrupt.		NO	NO
21	0956	Level 2 PCI (limit threshold)	NCP re-IPL	NO	NO

Note: In case of abend, NCP re-IPL is performed and the alarm/alert is generated when IPL is completed. Alert is triggered by MOSS BER ID 06, error code 05.

NCP/PEP BER Type 12 (Detailed BER Display)

NCP/PEP BER Type 12 - IDs 11 through 19: Format foN1, see page 11-193. Program level 1 generates one of these BERs when an NCP/PEP program exception occurs.

```

                                ELD DETAIL
SEL#:hhhh  FLAG:hh DATE:dd/dd TIME:dd:dd TYPE:hh ID:hh<LOST:ddd CP-ABEND:hhhh>
<ERROR DESCRIPTION>                                <REFER.CODE IN CHAR.> CCCCCC

X7E:hhhh  X74:hhhhhh  X79:hh  IAR:hhhhhh  I:hhhh

===>

F1:END F2:MENU2 F3:ALARM F4:SUMMARY F5:LIST F7:PREVIOUS F8:NEXT
    
```

NCP/PEP BER Type 12 - ID 21: Format foN2, see page 11-193. Program level 1 generates one of these BERs when a program-controlled interrupt request at level 2 remains unresolved.

```

                                ELD DETAIL
SEL#:hhhh  FLAG:hh DATE:dd/dd TIME:dd:dd TYPE:hh ID:hh<LOST:ddd CP-ABEND:hhhh>
<ERROR DESCRIPTION>                                <REFER.CODE IN CHAR.> CCCCCC

X7F:hhhh  IAR3:hhhhhhhh  IAR4:hhhhhhhh

===>

F1:END F2:MENU2 F3:ALARM F4:SUMMARY F5:LIST F7:PREVIOUS F8:NEXT
    
```

NCP/PEP BER Type 12 - Field Description

Table 11-64. NCP/PEP BER Type 12 Field Description		
Field Name	Meaning	Refer to
I	First two bytes of instruction.	
IAR	IAR of interrupt level.	--
IAR3	IAR contents of level 3.	--
IAR4	IAR contents of level 4.	--
X74	X'74' - Lagging address register.	Page 2-42
X79	X'79' - Byte 1 interrupted levels.	Page 2-26
X7F	X'7F' - Interrupt request reg - CCU levels 2, 3, and 4.	Page 2-26

Note: All values are in hexadecimal notation (X'0' to X'F').

NCP/PEP BER Type 12 - Formats

Format: foN1		Format: foN2	
IDs: 11 to 19		ID: 21	
Byte	Meaning	Byte	Meaning
1-27	Header	1-27	Header
28-29	TYPE-ID	28-29	TYPE-ID
30	LOST	30	LOST
31-32	Abend	31-32	Abend
33-34	X7E	33-34	X7F
35	Unused	35-38	IAR3
36-38	X74	39-42	IAR4
39	X79, byte 1		
40-42	IAR		
43-44	I		

Figure 11-24. NCP/PEP BER Formats

NCP CCU BER Type 13

CCU BER Type 13 - Summary

BER ID	Abend Code (NCP)	Event Description	Recovery or PGM Action	ALERT	ALARM
32	0	Level 3 interrupt configuration check <ul style="list-style-type: none"> Invalid level 3 interrupt (for example, CA interrupt on a link-attached 3745). 		NO	NO
32	0978	Level 3 interrupt configuration check (limit threshold)	NCP re-IPL	NO	NO
91	0	Unresolved level 1 interrupt, no bit in CA register X'E'.		NO	NO
91	0970	Unresolved level 1 interrupt (limit threshold)	NCP re-IPL	NO	NO
92	0971	Unresolved interrupted level when requested Interrupt level not 2, 3, 4, 5 as per contents of X'79' bits 1.0, 1.1, 1.2, 1.3.	NCP re-IPL	NO	NO
93	0972	Unexpected CCU hardcheck (CCU should have stopped) <ul style="list-style-type: none"> Not possible to reset X'77', bit 0.1, or MOSS has not reset this bit after IPL. 	NCP re-IPL	NO	NO
94	0973	Unexpected IPL request <ul style="list-style-type: none"> Not possible to reset X'77' bit 0.0, or MOSS has not reset this bit after IPL. 	NCP re-IPL	NO	NO
95	0971	Invalid level 1 interrupted IAR (IN X'79')	NCP re-IPL	NO	NO
B1	0	Unresolved level 3 interrupt NCP reading out X'77' does not find bit 1.0 ON (CA level 3) and X'7F' bits 0.2, 0.6, 1.5 and 1.6 ON (level 3 raised by MOSS diag, user, timer or PCI).		NO	NO
B1	0974	Unresolved level 3 interrupt (limit threshold)	NCP re-IPL	NO	NO
C1	0	Unresolved level 4 interrupt NCP reading out X'7F' does not find bits 0.3, 0.4, 0.7 and 1.7 ON (Level 4 interrupt raised by MOSS request SVC, MOSS response SVC, PCI or SVC).		NO	NO
C1	0975	Unresolved level 4 interrupt (limit threshold)	NCP re-IPL	NO	NO
C2	0	Unresolved level 4 PCI interrupt <ul style="list-style-type: none"> Level 4 PCI (X'7F' bit 0.7) and not wait state, but no bytes are set in level 4 control block of NCP. Mask used to set interrupt does not indicate release, slowdown, dispatcher request SVC interrupt, or mask indicates wait state plus MOSS offline, outmail box, CRP request for MOSS transfer, or MOSS request. 		NO	NO
C2	0976	Unresolved level 4 PCI interrupt (limit threshold)	NCP re-IPL	NO	NO
C3	0	Hot/spurious level 4 PCI Level 4 PCI latch (X'7F' bit 0.7) does not go OFF, after a reset by output X'77' bit 1.6		NO	NO
C3	0977	Hot/spurious level 4 PCI (limit threshold)	NCP re-IPL	NO	NO
C4	0979	Unresolved level 4 SVC interrupt Level 4 SVC interrupt (X'7F' bit 1.7) but CCU is in wait state. Abend if hot SVC interrupt (X'7F' bit 1.7 still ON after reset latch by Out X'77' bit 1.7).	NCP re-IPL	NO	NO

Table 11-65 (Page 2 of 2). CCU BER Type 13 Summary

BER ID	Abend Code (NCP)	Event Description	Recovery or PGM Action	ALERT	ALARM
C5	0	Continuous/unresolved MOSS level 4 request (X'7F' bit 0.3 still ON after reset latch by Out X'77' bit 0.4).		NO	NO
C5	097A	Continuous/unresolved MOSS level 4 request (limit threshold)	NCP re-IPL	NO	NO
C6	0	Continuous/unresolved MOSS level 4 status (X'7F' bit 0.4 still on after reset latch by Out X'77' bit 0.5).		NO	NO
C6	097B	Continuous/unresolved MOSS level 4 status (limit threshold)	NCP re-IPL	NO	NO

Note: In case of abend, NCP re-IPL is performed and the Alarm/Alert is generated when IPL is completed. Alert is triggered by MOSS BER ID 06, error code 05.

CCU BER Type 13 (Detailed BER Display)

CCU BER Type 13 - IDs 32, B1: Format foU1, see page 11-197. BER generated by program level 3.

```

                                ELD DETAIL
SEL#:hhhh  FLAG:hh  DATE:dd/dd  TIME:dd:dd  TYPE:13  ID:hh<LOST:ddd  CP-ABEND:hhhh>
<ERROR DESCRIPTION>                                <REFER.CODE IN CHAR.>  CCCCCCCC

X77:hhhh  X7F:hhhh  X0:hhhh  X1:hhhh  X2:hhhh  X3:hhhh  X4:hhhh  X5:hhhh
X6:hhhh  X7:hhhh  XB:hhhh  XC:hhhh  XF:hhhh
XD:hhhh  XE:hhhh  X0:hhhh  X1:hhhh  X2:hhhh
X3:hhhh  X4:hhhh  X5:hhhh  X6:hhhh  X7:hhhh
XB:hhhh  XC:hhhh  XD:hhhh  XE:hhhh  XF:hhhh
TA:hhhh  CCU-INPUT-X57:hhhh  CCU-OUTPUT-X57:hhhh

====>

F1:END  F2:MENU2  F3:ALARM  F4:SUMMARY  F5:LIST  F7:PREVIOUS  F8:NEXT

```

CCU BER Type 13 - IDs 91, 92, 93, 94, and 95: Format foU2, see page 11-197. This ID indicates an unresolved level 1 interrupt.

```

                                ELD DETAIL
SEL#:hhhh  FLAG:hh DATE:dd/dd TIME:dd:dd TYPE:13 ID:hh<LOST:ddd CP-ABEND:hhhh>
<ERROR DESCRIPTION>                                <REFER.CODE IN CHAR.> CCCCCCCC
F:bbbbbbbb
X7E:hhhh  X74:hhhhhh  X79:hh  IAR:hhhhhh  X7D:hhhh
CCU-INPUT-X57:hhhh  CCU-OUTPUT-X57:hhhh

====>

F1:END F2:MENU2 F3:ALARM F4:SUMMARY F5:LIST F7:PREVIOUS F8:NEXT
    
```

CCU BER Type 13 - IDs C1 to C6: Format foU3, see page 11-197. This ID indicates an unresolved level 4 interrupt.

```

                                ELD DETAIL
SEL#:hhhh  FLAG:hh DATE:dd/dd TIME:dd:dd TYPE:13 ID:hh<LOST:ddd CP-ABEND:hhhh>
<ERROR DESCRIPTION>                                <REFER.CODE IN CHAR.> CCCCCCCC

X77:hhhh  X7F:hhhh  RCB:hhhh hhhh hhhh hhhh
MTF: = 224 bytes (for ID C6 only)

====>

F1:END F2:MENU2 F3:ALARM F4:SUMMARY F5:LIST F7:PREVIOUS F8:NEXT
    
```

CCU BER Type 13 - Field Description

Table 11-66 (Page 1 of 2). CCU BER Type 13 Field Description

Field Name	Meaning	Refer to
IAR	IAR of interrupt level.	Chapter 7
MTF	Mailbox trace facility	
RCB	Level 4 router control block.	Chapter 7
X0	X'0' - Channel adapter initial selection register.	Chapter 7
X1	X'1' - CA CSCW and subchannel address.	Chapter 7
X2	X'2' - Data status register.	Chapter 7
X3	X'3' - CA ESC subchannel.	Chapter 7
X4	X'4' - CA IOH bytes 1 and 2.	Chapter 7
X5	X'5' - CA IOH bytes 3 and 4.	Chapter 7
X6	X'6' - CA NSC status register.	Chapter 7
X7	X'7' - CA enabled indications.	Chapter 7
XB	X'B' - CA ESC TIO address and status.	Chapter 7
XC	X'C' - CA AIO operations register.	Chapter 7
XD	X'D' - CA error register.	Chapter 7
XE	X'E' - CA level 1 interrupt requests.	Chapter 7
XF	X'F' - CA level 3 interrupt request and CA number.	Chapter 7
X74	X'74' - Cycle steal control word register.	Page 2-26
X77	X'77' - Interrupt request reg - adapter levels 2 and 3.	Page 2-26
X79	X'79' - Interrupted level.	Page 2-26
X7D	X'7D' - CCU hardcheck register.	Page 2-26
X7E	X'7E' - CCU level 1 interrupt.	Page 2-26
X7F	X'7F' - Interrupt request reg - CCU levels 2, 3, and 4.	Page 2-26

Table 11-66 (Page 2 of 2). CCU BER Type 13 Field Description		
Field Name	Meaning	Refer to
TA	Tag address	--
TD	Tag data	--
CCU INPUT X57	X'57' - Input CA command LS reg	Page 11-96
CCU OUTPUT X57	X'57' - Output CA command LS reg	Page 11-96

CCU BER Type 13 - Formats

Format foU1		Format foU2	
IDs: 32 B1		IDs: 91 to 95	
Byte	Meaning	Byte	Meaning
1-27	Header	1-27	Header
28-29	TYPE-ID	28-29	TYPE-ID
30	LOST	30	LOST
31-32	Abend	31-32	Abend
33-34	X'77'	33-34	X'7E'
35-36	X'7F'	35	Unused
37-62	IOCI registers X'00'-X'07' and X'0B'-X'0F'	36-38	X74
63-88	Unused	39	X79
89-90	TA	40-42	IAR
91-92	CCU input X57	43-44	X'7D' CCU hardcheck register
93-94	CCU output X57	45-46	CCU-input X57
95	BER flag	47-48	CCU-output X57
		49	BER flag
Format foU3			
IDs: C1 to C6			
Byte	Meaning		
1-27	Header		
28-29	TYPE-ID		
30	LOST		
31-32	CP ABEND		
33-34	X'77'		
35-36	X'7F'		
37-44	RCB		
45-46	NTF trace ident.*		
47-76	mailbox or status*		
77-78	NTF trace ident.*		
79-108	mailbox or status*		
109-110	NTF trace ident.*		
111-140	mailbox or status*		
141-142	NTF trace ident.*		
143-172	mailbox or status*		
173-174	NTF trace ident.*		
175-204	mailbox or status*		
205-206	NTF trace ident.*		
207-236	mailbox or status*		
237-238	NTF trace ident.*		
239-268	mailbox or status*		

* = Only for ID C6

Figure 11-25. CCU BER Formats

NCP IOC BER Type 14

IOC BER Type 14 - Summary

Table 11-67. IOC BER Type 14 Summary

BER ID	Abend Code (NCP)	Event Description	Recovery or PGM Action	ALERT	ALARM
17		PIO error. IOH or IOHI used by the control program when an invalid TA value of zero.	None	NO	NO
91	0	Unresolved adapter level 1		NO	NO
91	0990	Unresolved adapter level 1 (limit threshold)	NCP re-IPL	NO	NO
92	0	Unresolved AIO level 1 Attempt to cycle steal by undefined LA or CA. X'76' = 1A, 2A, 36, or B6 X'75' = Meaningless		NO	NO
92	0991	Unresolved AIO level 1 (limit threshold)	NCP re-IPL	NO	NO
93	0	Unresolved PIO level 1 PIO error detected by the IOC that was found unresolved (no time out or parity error, in X'76' bits 0.4 and 0.5).		NO	NO
93	0992	Unresolved PIO level 1 (limit threshold)	NCP re-IPL	NO	NO
96	0	Read switch error register failed <ul style="list-style-type: none"> • X'76' bit 0.4 for IOC1 time out • X'76' bit 0.5 for bus IN parity error X'76' bits 0.0, 0.1, 0.2, 0.3 contain the IOC internal error status at time of error			
9A	0990	IOC-X Unresolved Adapter LVL1 (threshold) No adapter identified as raising interrupt level 1	NCP abend	NO	E3
9C		IOC-X Unresolved Adapter LVL2 No adapter identified as raising interrupt level 2	None	NO	NO
9C	0937	IOC-X Unresolved Adapter LVL2 (threshold) No adapter identified as raising interrupt level 2	NCP abend	No	E3

Note: In case of abend, an NCP re-IPL is performed and the alarm/alert is generated when IPL is completed. Alert is triggered by the MOSS BER ID 06, error code 05.

3746-900 BER Type 14 - ID 17: Format fol1, see page 11-200.

```

                                ELD DETAIL
SEL# hhh  FLAG hh DATE:dd/dd TIME:dd:dd TYPE:09 ID:hh
<ERROR DESCRIPTION>                <REFER.CODE IN CHAR.> CCCCCC
X7E:hhhh LAR:hhhh hhhh INTLVL:hh IAR:hhhhh X76:hhhh LIBIOHTA:hhhh
LIBIOHTD:hhhh L1XSWADE:hhhh L1BERFLG:hh

===>

F1:END F2:MENU2 F3:ALARM F4:SUMMARY F5:LIST F7:PREVIOUS F8:NEXT
    
```

IOC BER Type 14 (Detailed BER Display)

All IDs (91, 92, 93, 96): See format fol1, on page 11-200. Program level 1 generates one of these BERs when an error occurs on the IOC bus.

```

                                ELD DETAIL
SEL#:hhhh  FLAG:hh DATE:dd/dd TIME:dd:dd TYPE:10 ID:hh<LOST:ddd CP-ABEND:hhhh>
<ERROR DESCRIPTION>                                <REFER.CODE IN CHAR.> CCCCCCCC
F:bbbbbbbb
X7E:hhhh  X76:hhhh  X75:hhhh X74:hhhhhhhh X76U:hhhh
SWA:
CCU-INPUT-X57:hhhh  CCU-OUTPUT-X57:hhhh

====>

F1:END F2:MENU2 F3:ALARM F4:SUMMARY F5:LIST F7:PREVIOUS F8:NEXT

```

3746-900 BER Type 14 - IDs 9A and 9C: Format fol3, see page 11-200.

```

                                ELD DETAIL
SEL# hhh  FLAG hh DATE:dd/dd TIME:dd:dd TYPE:09 ID:hh
<ERROR DESCRIPTION>                                <REFER.CODE IN CHAR.> CCCCCCCC
X7E:hhhh LAR:hhhh hhhh INTLVL:hh IAR:hhhhhh X76:hhhh L1BIOHTA:hhhh
L1BIOHTD:hhhh L1BPIO76:hhhh L1XSWADE:hhhh L1BPIOTA:hhhh L1BERFLG:hh

====>

F1:END F2:MENU2 F3:ALARM F4:SUMMARY F5:LIST F7:PREVIOUS F8:NEXT

```

IOC BER Type 14 - Field Description

Table 11-68 (Page 1 of 2). IOC BER Type 14 Field Description		
Field Name	Meaning	Refer to
IAR	IAR of interrupt level.	page 2-42
INTLVL	Interrupt level	-
LAR	Lagging Address Register (X'74').	page 2-42
L1BERFLG	Box event record flags	page 11-158
L1BIOHTA/ L1BPIOTA	IOHI image -- TA data register (TA: hhhh means data bytes 0 and 1).	page 3-36
L1BIOHTD	IOHI image -- TD data adapter specific bytes (TD: hhhh means data bytes 0 and 1).	-
L1XSWADE	Unused	
L1BPIOH76	X'76' - IOC error summary register.	page 2-34
CAB	CAB error register.	
F	Indicator flag byte (byte extention)	(*)
X74	X'74' - Lagging address register (LAR) bytes.	Page 2-26
X75	X'75' - Cycle steal control word register.	Page 2-26
X76	X'76' - IOC error summary register.	Page 2-26
X76U	X'76' - Cause of error not found (PIO to read error register failed). See page 11-13	Page 2-26
X7E	X'7E' - CCU level 1 interrupt.	Page 2-26
SWA	Unused	

Table 11-68 (Page 2 of 2). IOC BER Type 14 Field Description		
Field Name	Meaning	Refer to
CCU INPUT-X57	CCU input command LS register (same for "OUTPUT")	Page 11-96

Note: All values are in hexadecimal format (X'0' to X'F'), except for the flag indicator F, which is in bit format (8 bits, 0 or 1).

(*) For software information on BERs originated by NCP/PEP, refer to the associated product documentation.

IOC BER Type 14 - Format

Format: foI1		Format: foI2	
ID: 17		IDs: 91 92 93 96	
Byte	Meaning	Byte	Meaning
1-27	Header	1-27	Header
28-29	TYPE-ID	28-29	TYPE-ID
30	Lost	30	Lost
31-32	Abend	31-32	Abend
33-34	X7E	33-34	X7E
35-38	LAR	35-36	X76
39	INTVL	37-38	X75
40-42	IAR	39-42	X74
43-44	X76	43-44	Unused
45-46	LIBIOHTA	45-46	X76U
47-48	LIBIOHTD	47-48	CCU input X57
49-50	Unused	49-50	CCU output X57
51-52	LIXSWADE	51	Flag
53-54	Unused	52	Unused
55-56	LIBERFLG	53-54	SWA
Format: foI3			
IDs: 9A 9C			
Byte	Meaning		
1-27	Header		
28-29	TYPE-ID		
30	Lost		
31-32	Abend		
33-34	X7E		
35-38	LAR		
39	INTVL		
40-42	IAR		
43-44	X76		
45-46	LIBIOHTA		
47-48	LIBIOHTD		
49-50	LIBPIO76		
51-52	LIXSWADE		
53-54	LIBPIOTA		
55-56	LIBERFLG		

Figure 11-26. IOC BER Format

NCP TRSS BER Type 15

TRSS BER Type 15 - Summary

<i>Table 11-69 (Page 1 of 3). TRSS BER Type 15 Summary</i>				
BER ID	Abend Code (NCP)	Event Description	Recovery or PGM Action	ALARM/ALERT
14	0B01	Address exception (AIO) X'76' bit 0.0 or 1.0 ON	NCP re-IPL	NO
16	0B02	Storage protect (AIO) X'76' bit 0.1 or 1.1 ON	NCP re-IPL	NO
18	0	IOH/IOHI to TRM not installed X'7E' bit 0.5 or 1.5 ON IOC bus check in error status type 1 of TRM bit 0.1 and 0.5 on (X'02 bits 0.1 and 0.5)		89
91	0	TRM AIO error <ul style="list-style-type: none"> X'75' bit 0.0 or 1.5 ON X'76' bit 0.4 ON for IOC1 time out X'76' bit 0.5 ON for IOC bus in parity error X'76' bit 0.6 ON in both cases (AIO) <ul style="list-style-type: none"> X'76' bits 0.0, 0.1, 0.2, 0.3 contain the IOC internal status at time of error. 	TIC retry	NO
91	0	TRM AIO error (threshold)	TRM down	82
92	0	TRM AIO error unresolved	TIC retry	NO
92	0	TRM AIO error unresolved (limit threshold)	TRM down	82
93	0	TRM AIO invalid CSCW <ul style="list-style-type: none"> X'75' bit 0.0 or 1.0 ON X'76' bits 0.2 and 0.6 or 1.2 and 1.6 ON 	TIC retry	NO
93	0	TRM AIO invalid CSCW (limit threshold)	TRM down	82
96	0	TRM disconnect state (following request from MOSS) <ul style="list-style-type: none"> X'7E' bit 0.2 or 0.6 ON Error status, bit 0.7 ON Ext register X'01' bit 5 ON 	TRM OFF line	B9
97	0	TRM PIO error-output IOH/IOHI <ul style="list-style-type: none"> X'75' bit 0.0 or 1.0 ON X'76' bit 0.4 ON for IOC1 time out X'76' bit 0.5 for IOC bus in parity error X'76' bit 0.6 OFF in both cases Origin given in error status type 1 of TRM	NCP retry	NO
97	0	TRM PIO error-output IOH/IOHI (limit threshold)	TRM down	NO
98	0	TRM PIO error-output IOH/IOHI (over threshold)	TRM down	82
99	0	TRA adapter error (IOH bit 1.7 ON)	TRM down	82
9A	0	TRM adapter error unresolved <ul style="list-style-type: none"> First get error status failed but retry was successful Error status has value at time of failure 		NO
9A	0	TRM adapter error unresolved (limit threshold) Error status filled by X'FFFF'	TRM down	82

TRSS BER

<i>Table 11-69 (Page 2 of 3). TRSS BER Type 15 Summary</i>				
BER ID	Abend Code (NCP)	Event Description	Recovery or PGM Action	ALARM/ALERT
9B	0	Interrupt from disconnected TRM <ul style="list-style-type: none"> Level 1 interrupt presented to NCP/PEP while the TRM is disconnected (X'01' bit 5 ON) X'7E' bit 0.2 or 0.6 ON 		NO
9B	0	Interrupt from disconnected TRM (limit threshold)	TRM down	NO
9B	XXXX	Interrupt from disconnected TRM	NCP re-IPL	NO
9C	0	Adapter PIO error on broadcast "get line ID" IOH command Adapter was the answering one at failure time.	NO	NO
9C	0	Adapter PIO error on broadcast "get line ID" IOH command Adapter was the answering one at failure time. (threshold)	Adapter down	83
83				
9E	0	Get error status command error, after PIO (see type 15 ID 9A and 9c)	NCP re-IPL	83
A3	0	Invalid level 2 interrupt	TIC down	80
A4	0	DMA or interrupt vector error due to TIC interrupt level 2 <ul style="list-style-type: none"> TRM status bit 0 ON TRM status bits 4, 5 not '000' 	TIC retry	NO
A4	0	DMA or interrupt vector error due to TIC (limit threshold)	TIC down	80
A5	0	DMA or interrupt vector error due to TRM Interrupt level 2 <ul style="list-style-type: none"> TRM status bit 0 ON TRM status bit 6 ON 	TIC retry	NO
A5	0	DMA or interrupt vector error due to TRM (limit threshold)	TRM down	83
A7	0	PIO-MMIO error interrupt level 2 <ul style="list-style-type: none"> TRM status bit 0 ON TRM status bits 1, 2, 3 neither '000' nor '001' 	TIC retry	NO
A7	0	PIO-MMIO error (limit threshold)	TIC down	80
A8	0	PIO-MMIO error (last TIC) <ul style="list-style-type: none"> TRM status bit 0 ON TRM status bits 1, 2, 3 = '001' 	TRM retry	NO
A8	0	PIO-MMIO error (last TIC) <ul style="list-style-type: none"> TRM status bit 0 ON TRM status bits 1, 2, 3 = '001' 	TRM down	83
AC	0	TIC adapter check interrupt level 2 <ul style="list-style-type: none"> TRM status bit 0 OFF TRM status bit 3 ON 	TIC down	80
AF	0	TIC down at open time <ul style="list-style-type: none"> Interrupt level 2 SSB open completion bit 6 ON 	TIC down	85
B2	0	TIC/TRM check at initialization time	TIC retry	NO
B2	0	TIC/TRM check at initialization time (limit threshold)	TIC down	(2)

Table 11-69 (Page 3 of 3). TRSS BER Type 15 Summary

BER ID	Abend Code (NCP)	Event Description	Recovery or PGM Action	ALARM/ALERT
B3	0	Back-up time out. No completion interrupt level 2 received during the back-up timer with : <ul style="list-style-type: none"> • TIC control register bits 0, 1, 3 OFF • IR/BR register bit interrupt request OFF 	TIC down	87
B4	0	Component out of use <ul style="list-style-type: none"> • 'Interrupt occurred' flag OFF when the timer elapses and no interrupt received • 'Write interrupt register' with SCB 	TIC down	8B
B5	0	Back-up time out (last TIC). No completion interrupt level 2 received during the back-up timer with : <ul style="list-style-type: none"> • TIC control register bits 0, 1, 3 OFF, and • IR/BR register bit interrupt request ON, or • TIC control register bits 0, 1, 3 not all OFF 	TRM down	81
B6	0	Incomplete frame time out No interrupt level 2 received during the incomplete frame timer	TIC down	8C
B7	0	Token ring link error not caused by controller hardware.	TIC down	8E

Notes:

1. In case of abend, NCP re-IPL is performed and the Alarm/Alert is generated when IPL is completed. Alert is triggered by MOSS BER ID 06, error code 05.
2. BER ID B2 may generate diferent alerts according to the value of the interrupt register (see alerts 8D, 84, 80).

TRSS BER Type 15 (Detailed BER Display)

TRSS BER Type 15 - IDs 14, 16, 91, 92, 93: Format foR1, see page 11-208. Program level 1 generates one of these BERs when an error occurs during an AIO operation on a TRA.

```

                                ELD DETAIL
SEL#:ddd FLAG:hh DATE:dd/dd TIME:dd:dd TYPE:15 ID:hh <LOST:ddd CP-ABEND:hhh>
TRMnn TICn <ERROR DESCRIPTION>                                <REFER.CODE IN CHAR.> CCCCCCCC
F:bbbbbbbb
X7E:hhhh X76U:hhhh ETA:hhhh X3F:hhhhhhhh X75:hhhh

X76 TRM STATUS1 SWA ERROR REG
hhhh bbbbbbbb bbbbbbbb bbbbbbbb bbbbbbbb

====>

F1:END F2:MENU2 F3:ALARM F4:SUMMARY F5:LIST F7:PREVIOUS F8:NEXT
    
```

TRSS BER Type 15 - IDs 18, 97, 98, 9C: Format foR2, see page 11-208.
 Program level 1 generates one of the following BERs when an error occurs during a PIO operation on a TRA.

```

                                ELD DETAIL
SEL#:ddd FLAG:hh DATE:dd/dd TIME:dd:dd TYPE:15 ID:hh <LOST:ddd CP-ABEND:hhh>
TRMnn TICn <ERROR DESCRIPTION>                                <REFER.CODE IN CHAR.> CCCCCCCC
F:bbbbbbbbb
X7E:hhhh X76U:hhhh ETA:hhhh X74:hhhhhhhh
X79:hh IAR:hhhhhh I:hhhh TA:hhhh TD:hhhh

X76 TRM STATUS1 SWA ERROR REG
hhhh bbbbbbbb bbbbbbbb bbbbbbbb bbbbbbbb

====>

F1:END F2:MENU2 F3:ALARM F4:SUMMARY F5:LIST F7:PREVIOUS F8:NEXT
    
```

TRSS BER Type 15 - ID 96, 99, 9A, 9B: Format foR3, see page 11-209.
 Program level 1 generates one of the following BER when a TRM is disconnected by MOSS, or when an error is exported by a TRM on level 1.

```

                                ELD DETAIL
SEL#:hhhh FLAG:hh DATE:dd/dd TIME:dd:dd TYPE:15 ID:hh<LOST:ddd CP-ABEND:hhh>
TRMnn TICn <ERROR DESCRIPTION>                                <REFER.CODE IN CHAR.> CCCCCCCC
F:bbbbbbbbb
X7E:hhhh X76U:hhhh TRMA:hh
X76 TRM STATUS1 SWA ERROR REG
hhhh bbbbbbbb bbbbbbbb bbbbbbbb bbbbbbbb

====>

F1:END F2:MENU2 F3:ALARM F4:SUMMARY F5:LIST F7:PREVIOUS F8:NEXT
    
```

TRSS BER Type 15 - IDs A3, A4, A5, A7, A8: Format foR4, see page 11-209.
 Program level 2 generates one of the following BERs when an error occurs (internal TRM/TIC error).

```

                                ELD DETAIL
SEL#:ddd FLAG:hh DATE:dd/dd TIME:dd:dd TYPE:15 ID:hh
TRMnn TICn <ERROR DESCRIPTION>                                <REF. CODE IN CHAR.> CCCCCCCC
F:bbbbbbbbb
TA:hhhh TICA:hh
TRM STATUS2
bbbbbbbbb bbbbbbbb

====>

F1:END F2:MENU2 F3:ALARM F4:SUMMARY F5:LIST F7:PREVIOUS F8:NEXT
    
```

TRSS BER Type 15 - ID AC: Format foR5, see page 11-209. Program level 2 generates the following BER when a TIC adapter check occurs on a TIC.

```

                                ELD DETAIL
SEL#:ddd FLAG:hh DATE:dd/dd TIME:dd:dd TYPE:15 ID:hh <LOST:ddd CP-ABEND:hhh>
TRMnn TICn <ERROR DESCRIPTION>                                <REF. CODE IN CHAR.> CCCCCC
F:bbbbbbb
TA:hhh TICA:hh
TRM STATUS2
bbbbbbb bbbbbbb
TIC ADAPTER CHECK STATUS:
bbbbbbb bbbbbbb hhhh hhhh hhhh

====>

F1:END F2:MENU2 F3:ALARM F4:SUMMARY F5:LIST F7:PREVIOUS F8:NEXT

```

TRSS BER Type 15 - ID AF: Format foR6, see page 11-209. Program level 2 generates the following BER when a TIC check occurs at open time.

```

                                ELD DETAIL
SEL#:hhh FLAG:hh DATE:dd/dd TIME:dd:dd TYPE:15 ID:hh<LOST:ddd CP-ABEND:hhh>
<ERROR DESCRIPTION>                                <REF. CODE IN CHAR.> CCCCCC
F:bbbbbbb
TA:hhh TICA:hh
TRM STATUS2
bbbbbbb bbbbbbb
SSB
hhh bbbbbbb bbbbbbb

====>

F1:END F2:MENU2 F3:ALARM F4:SUMMARY F5:LIST F7:PREVIOUS F8:NEXT

```

TRSS BER Type 15 - ID B2: Format foR7, see page 11-209. Program level 3 generates the following BER when a TIC/TRM check occurs on a command sent to a TRM.

```

                                ELD DETAIL
SEL#:hhh FLAG:hh DATE:dd/dd TIME:dd:dd TYPE:15 ID:hh<LOST:ddd CP-ABEND:hhh>
<ERROR DESCRIPTION>                                <REF. CODE IN CHAR.> CCCCCC
F:bbbbbbb
TA:hhh                TICA:hh
TRM IIR                TIC CTL REGISTER
bbbbbbb bbbbbbb      bbbbbbb bbbbbbb

====>

F1:END F2:MENU2 F3:ALARM F4:SUMMARY F5:LIST F7:PREVIOUS F8:NEXT

```

TRSS BER Type 15 - IDs B3, B4, B5, B6: Format foR8, see page 11-209. Program level 3 generates one of the following BERs when a time out occurs on a command sent to a TRM.

```

                                ELD DETAIL
SEL#:hhhh  FLAG:hh DATE:dd/dd TIME:dd:dd TYPE:15 ID:hh<LOST:ddd CP-ABEND:hhhh>
<ERROR DESCRIPTION>                                <REF. CODECIN CHAR.> CCCCCC
F:bbbbbbbb
TA:hhhh          TICA:hh
TRM IR/BR        TIC CTL REGISTER
bbbbbbbb bbbbbbbb bbbbbbbb bbbbbbbb

====>

F1:END F2:MENU2 F3:ALARM F4:SUMMARY F5:LIST F7:PREVIOUS F8:NEXT
    
```

TRSS BER Type 15 - ID B7: Format foR9, see page 11-210. Program level 3 generates the following BER when an external token ring physical link error occurs.

```

                                ELD DETAIL
SEL#:hhhh  FLAG:hh DATE:dd/dd TIME:dd:dd TYPE:15 ID:hh<LOST:ddd CP-ABEND:hhhh>
<ERROR DESCRIPTION>                                CCCCCC
F:bbbbbbbb
ALERT:hh        TICA:hh
PLM STATUS:hh

Q3: bbbbbbbb bbbbbbbb bbbbbbbb bbbbbbbb

====>

F1:END F2:MENU2 F3:ALARM F4:SUMMARY F5:LIST F7:PREVIOUS F8:NEXT
    
```

TRSS BER Type 15 - Field Description

Table 11-70 (Page 1 of 2). TRSS BER Type 15 Field Description		
Field Name	Meaning	Refer to
TICA	TIC internal address 00-01 (within the TRM)	Chapter 6
TRM STAT2	TRA level 2 error status	Chapter 6
TRMnn	TRM number (decimal in error description field). This TRM number is derived from: <ul style="list-style-type: none"> • field TA for PIO operation <ul style="list-style-type: none"> – for CS error reported at level 2 – for CA error reported at level 3 • field X75 for AIO operation • field TRM status level 1 for TRM adapter error reported at level 1 If no nn is specified (blank), problem isolation by program was not possible.	
TICn	TIC number 1-2 within the TRM	
TIC adapter check status	Four halfwords giving the reason of a TIC microcode abend	Chapter 6
TRM STAT1	TRA level 1 error status	Chapter 6
TRM IR/BR	Interrupt request/bus request flags	Chapter 6
TIC CTL	TIC control register	Chapter 6
REG		
TRM IIR	TIC interrupt register (initialize)	Chapter 6

Field Name	Meaning	Refer to
TA/TD ETA F TRMA	TA field of IOH failure in level 1. Indicator flag, indicates a byte expansion follows TRM address	Chapter 6
I IAR X3F X74 X75 X76 X76U	First two bytes of instruction. IAR of interrupt level. CSP shared pointer register X'74' - LAR bytes X'75' - Cycle steal control word register X'76' - IOC error summary register X'76' - Cause of error not found (PIO to read error register failed)	Chapter 4 Page 2-26 Page 2-26 Page 2-26 Page 2-26
X77 X79 X7E X7F SSB SWA ALERT	X'77' - Interrupt request reg - adapter level 2 and 3 X'79' - Interrupt level X'7E' - CCU level 1 interrupt X'7F' - Interrupt request reg - CCU level 2, 3, and 4 System status block Unused NTRI alert number (external error code for alarm 8E)	Page 2-26 Page 2-26 Page 2-26 Page 2-26 (*) Alarm 8E in the PD Guide
PLM STATUS Q3	Physical link status at time of error Qualifier 3 of the alert	page 11-208 (*)

Note: All values are in hexadecimal format (X'0' to X'F'), except for:

1. The TIC ADPT CHECK STAT, SSB, TRM IR/BR, TIC CTL register, TRM IIR, TRM status 1, TRM status 2, which are in **bit format** (8 or 16 bits, 0 or 1)
2. The error description line with a TRM number and TIC number, which are in **decimal**.

(*) For software information on BERs originated by NCP/PEP, refer to the associated product documentation.

:h4Physical Link (PLM) Status Definition

PLM Status (Hexa)	Meaning
00	Inactive: Physical link is not activated
01	Activating: TIC initialization in progress
02	Activating: TIC initialization complete
03	Activating: Open in progress
05	Active: Physical link is activated
06	Deactivating: Close in progress
07	Deactivating: Closed
08	Active or deactivating: Requested statistics from TIC
09	Active: Ring beaconing in progress
0A	Deactivating: Deactivation from host in progress

TRSS BER Type 15 - Formats

Format: foR1		Format: foR2	
IDs: 14 16 91 92 93		IDs: 18 97 98 9C	
Byte	Meaning	Byte	Meaning
1-27	Header	1-27	Header
28-29	TYPE-ID	28-29	TYPE-ID
30	LOST	30	LOST
31-32	Abend	31-32	Abend
33-34	X7E	33-34	X7E
35-36	X76	35-36	X76
37-38	X75	37-38	I
39-40	Unused	39-42	X74
41-42	ETA	43-44	TRM STATUS1
43-44	TRM STATUS1	45-46	X76U
45-46	X76U	47-48	ETA
47-50	X3F	49-50	Unused
51	F	51	F
52	Unused	52	Unused
53-54	SWA	53-54	SWA
55-72	Unused	55	X79
		56-58	IAR
		59-60	TA
		61-62	TD

Figure 11-27 (Part 1 of 3). TRSS BER Formats

Format: foR3	
IDs: 96 99 9A 9B	
Byte	Meaning
1-27	Header
28-29	TYPE-ID
30	LOST
31-32	Abend
33-34	X7E
35-36	X76
37	TRM address
38-42	Unused
43-44	TRM STATUS1
45-46	X76U
47-50	Unused
51	F
52	Unused
53-54	SWA
55-74	Unused
75-76	ETA

Format: foR4	
IDs: A3 to A8	
Byte	Meaning
1-27	Header
28-29	TYPE-ID
30	LOST
31-32	Abend
33	F
34	TICA
35-36	TA data
37-38	TRM STATUS2

Format: foR5	
ID: AC	
Byte	Meaning
1-27	Header
28-29	TYPE-ID
30	LOST
31-32	Abend
33	F
34	TICA
35-36	TA data
37-38	TRM STATUS2
39-46	Adapter check status

Format: foR6	
ID: AF	
Byte	Meaning
1-27	Header
28-29	TYPE-ID
30	LOST
31-32	Abend
33	F
34	TICA
35-36	TA data
37-38	TRM STATUS2
39-42	SSB open completion

Format: foR7	
IDs: B3 to B6	
Byte	Meaning
1-27	Header
28-29	TYPE-ID
30	LOST
31-32	Abend
33	F
34	TICA
35-36	TA data
37-38	TRM IR/BR register
39-40	TIC control register

Format: foR8	
ID: B2	
Byte	Meaning
1-27	Header
28-29	TYPE-ID
30	LOST
31-32	Abend
33	F
34	TICA
35-36	TA data
37-38	TIC init interrupt register
39-40	TIC control register

Figure 11-27 (Part 2 of 3). TRSS BER Formats

Format: foR9

ID: B7	
Byte	Meaning
1-27	Header
28-29	TYPE-ID
30	LOST
31-32	Abend
33	F
34	TICA
35-36	TA data
37	NTRI Alert number
38	PLM status
39-42	Alert Q3 field

Figure 11-27 (Part 3 of 3). TRSS BER Formats

Chapter 12. Ethernet Subsystem (ESS)

The ESS in 3745 Models 130, 150, 160, and 170 Data Flow	12-3
The ESS in 3745 Model 17A Data Flow	12-4
Introduction	12-5
System Environment	12-5
ELA Packaging	12-5
Line Addressing	12-6
ELA Commands	12-7
Interface or Port Types	12-7
ESS Data Flow	12-8
Frame Types Supported	12-9
Ethernet Version 2	12-9
IEEE 802.3 Frame	12-10
ELA Microcode Description	12-11
ELA Microcode Functions	12-11
ELA Microcode Structure	12-11
Internal Interconnections	12-13
CSP-to-IOC Bus	12-13
EAC to CSP	12-13
EAC to DMA Bus	12-13
Communication Scanner Processor (CSP)	12-14
Ethernet LAN Coupler Card (EAC)	12-15
CSP Layer	12-16
DMA Manager Layer	12-16
Address PROM Layer	12-16
Bus Interconnection Layer	12-16
Transmit/Receive Control Layer	12-17
Serial Conversion and Coding Layer	12-17
Isolation Layer	12-17
Reset EAC	12-17
ELA Command Description	12-18
Set Mode	12-18
Enable	12-19
Disable	12-20
Change	12-21
Transmit Data	12-21
Receive	12-22
Get Counters	12-23
Halt	12-23
Halt Immediate Command	12-24
Parameter/Status Area	12-25
Input/Output Instruction Formats	12-25
CSP Addressing	12-28
Parameter/Status Area Layout	12-29
Status Control Field (SCF)	12-29
Current Command (CCMD)	12-30
Secondary Status (SES)	12-30
Line Communication Status (LCS)	12-30
Error Detection and Reporting	12-36
Program/Hardware Checks	12-36
Hardware Error Detection and Reporting	12-36

DMA Interconnection Errors Detected by EAC (Register X'10')	12-38
CSP Interconnection Errors	12-41
EAC Internal Checkers	12-42
Error Status	12-42
Diagnostic Facilities	12-44
Problem Determination Aid	12-45
NCP Buffer Prefix Validity Checking in Receive	12-45
SIT Trace	12-45

The ESS in 3745 Models 130, 150, 160, and 170 Data Flow

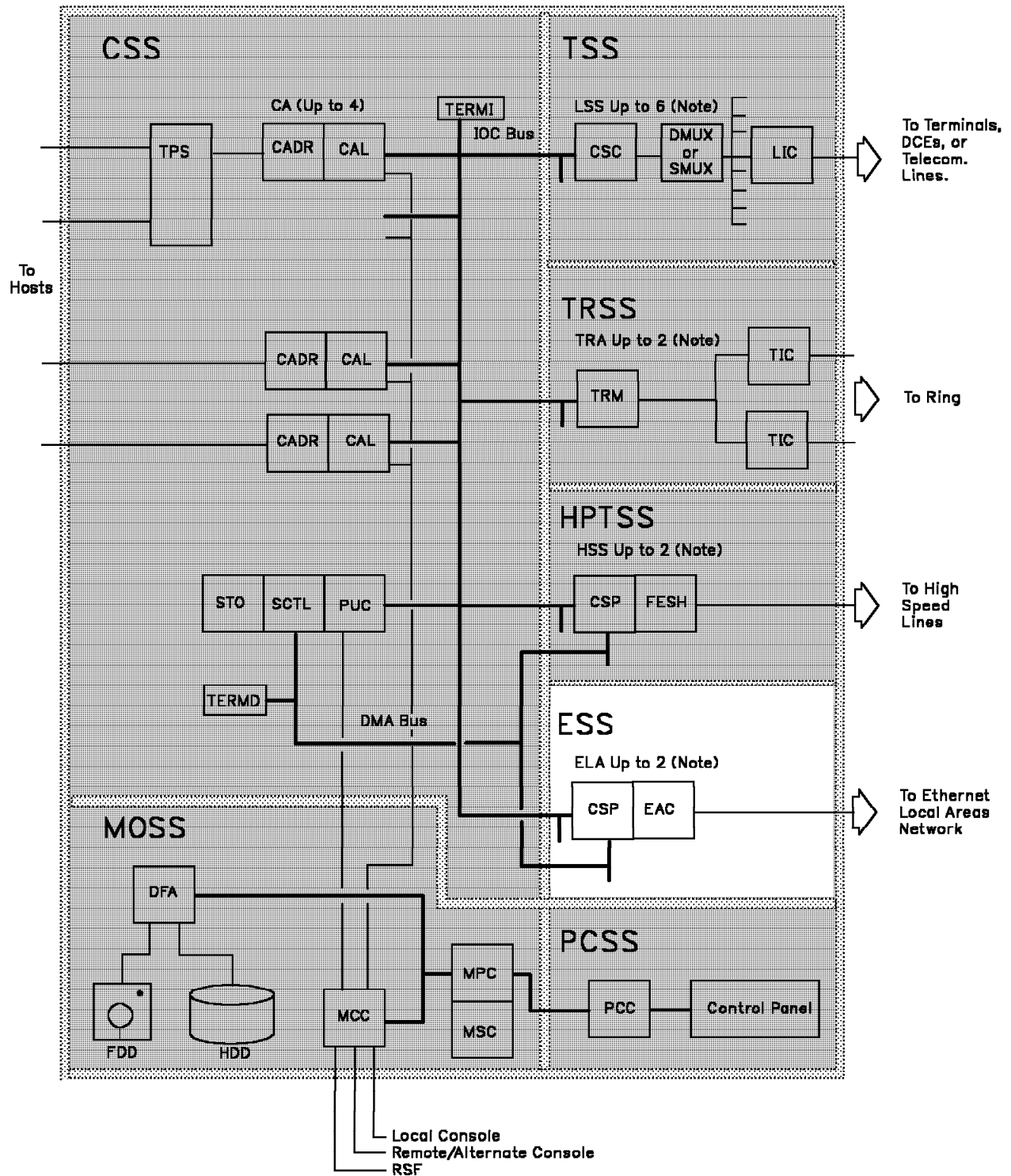

(Note) The number of LSS+HSS+ELA does not exceed 6

The ESS in 3745 Model 17A Data Flow

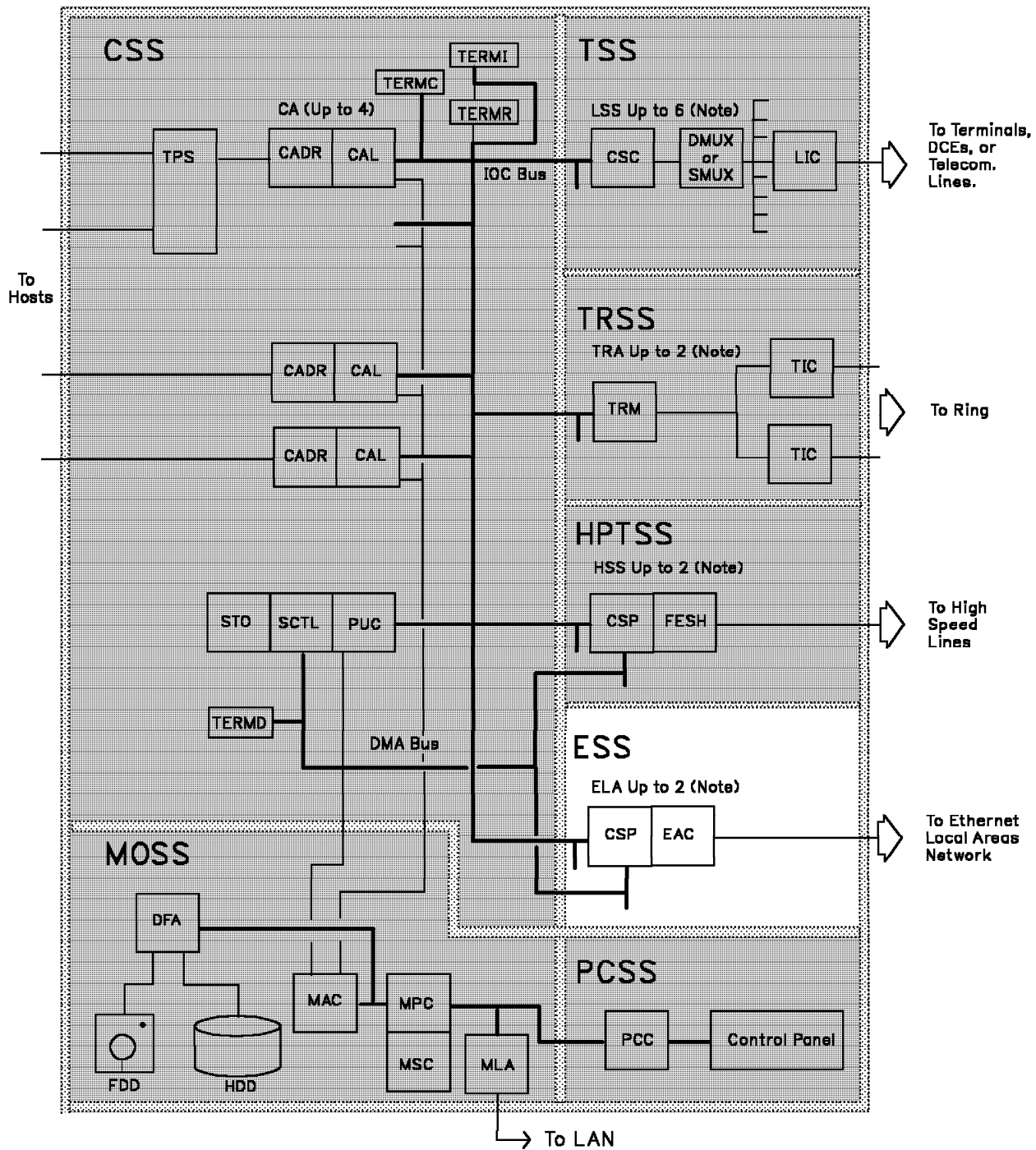

(Note) The number of LSS+HSS+ELA does not exceed 6

Figure 12-1. The ESS in 3745 Model 17A Data Flow. For model 17A, DMA and IOC buses are connected to the CBC in the 3746-900. This MLA card links the MOSS to the Service Processor through a LAN.

Introduction

The Ethernet LAN subsystem (ESS) attaches a maximum of four Ethernet-type local area networks (maximum of two when token-ring adapters are installed). It consists of up to two Ethernet LAN adapters (ELA). Each adapter can attach up to two Ethernet-type LANs, through a media adapter unit (MAU) operating at 10 million bits per second (Mbps).

The Ethernet LAN adapter (ELA) can be installed in all 3745 models (configuration dependent).

Ethernet subsystem provides attachment to a carrier sense multiple access, with collision detection (CSMA/CD).

System Environment

The ELA supports both Ethernet LAN Version 2 and IEEE 802.3 frames.

ELA Packaging

The handling and management of such a communication is achieved by an Ethernet LAN adapter (ELA) made of two cards:

- One communication scanner processor packaged on one card, the CSP card identical to those of the high-speed scanner (HSS) but with a different CSP microcode load module (see "ELA Microcode Description" on page 12-11).
- One Ethernet adapter card, the EAC card.

ELA is installed in HSS positions.

The ELA interface to the external equipment is a IEEE 802.3 15-pin D-type female AUI connector requiring a slide latch on mounting connector. The ESS uses the tail gate location of the corresponding HPTSS.

For board and card locations, refer to the "Maintenance Information Procedures", SY33-2070.

The tail gate contains also a DC/DC converter, one per port, which provides + 12V DC with up to 500 mA per port. The + 12V DC supplies an external transceiver called media access unit (MAU).

On the tail gate a green LED is On when the + 12 V DC is present on the corresponding J connector.

Use of MAUs

The performance of the Ethernet feature have been checked with a wide range of OEMs MAUs. Although meeting the 802.3 standards, some MAUs are more sensitive than others to electromagnetic environment and may degrade the box performance related to the noise margin.: The MAU must be equipped with the SQE-TEST (also called HEARTBEAT) function.

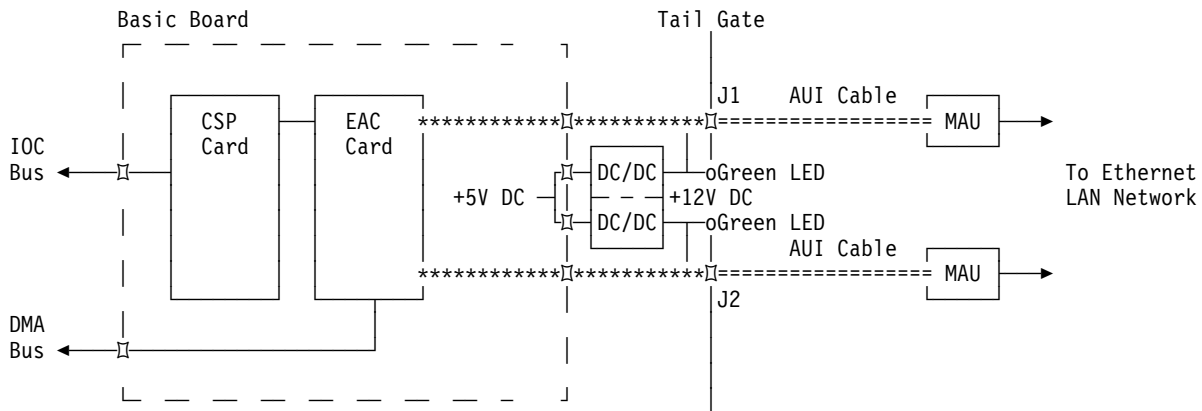

Up to two ELAs (coupled CSP/EAC cards) may be installed on the basic board, to control up to four data links at one time.

On each EAC two data links to be connected at the tail gate to that EAC. Both ports can be active at the same time.

Line Addressing

Each ELA supports a maximum of two line addresses.

With two possible ELAs, the maximum number of lines is four. Line numbers 1060 through 1063 are dedicated for ELA use.

The two lines associated with a particular ELA are addressed by the TD1 field of the IOH. TD1 bit 6 selects one of the two lines. TD1 bit 7 selects either the transmit or receive interface of the line. When TD1 bit 7 = 0 it selects the transmit interface and when TD1 bit 7 = 1 it selects the receive interface.

Refer to "ESS Line Addressing" on page 3-45 for the mapping of the lines between the boards and the tail gate.

ELA Commands

Commands are set in TD0 of the start line or start line initial instructions. The following NCP commands are supported by the ELA:

Commands	Codes (Hex)
Set mode	01
Enable	02
Disable	03
Change	06
Transmit Data	51
Receive Data	53
Trace	2C
Stop trace	2D
Halt	F0
Halt immediate	F1
Dump Control blocks (no status)	F4
Dump Control blocks (status)	F5
Suspend Receive	F8
Get Counters	50

For details on ELA commands, see “ELA Command Description” on page 12-18.

Interface or Port Types

Up to eight ELAs attaching up to four Ethernet LAN Version 2 or IEEE 802.3 networks operating at 10 Mbps.

ESS Data Flow

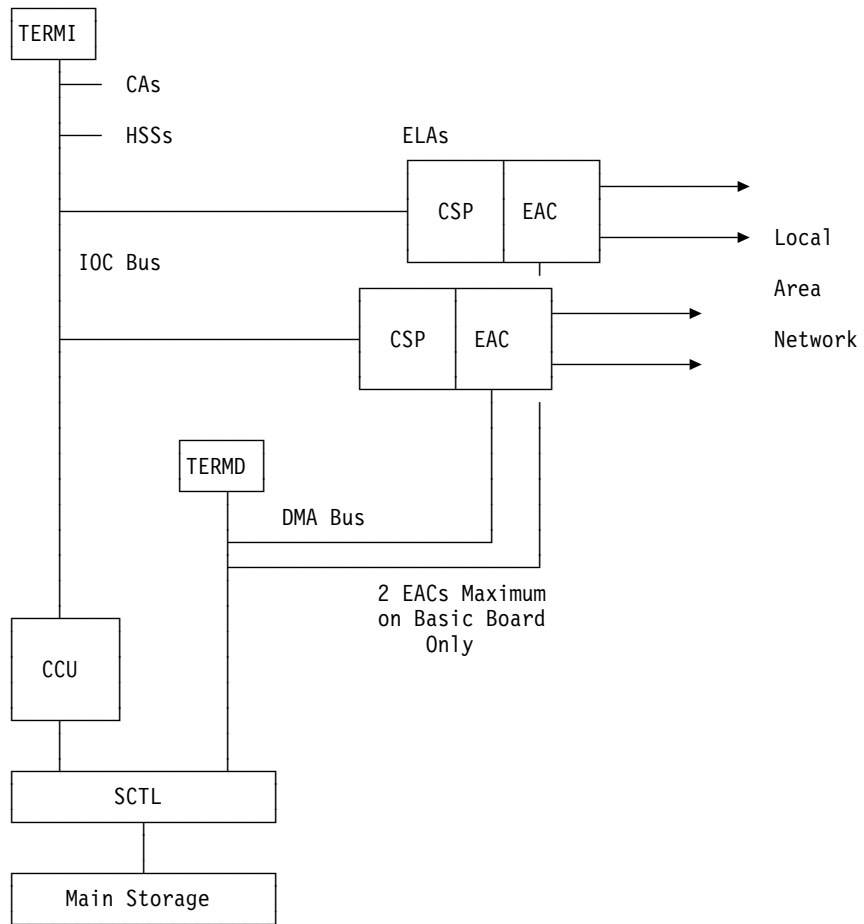

Figure 12-2. ESS Data Flow

Frame Types Supported

The ESS supports two types of frame:

- Ethernet Version 2 (Ethernet V2) frame
- IEEE 802.3 frame.

Internet Protocol (IP) and Address Resolution Protocol (ARP) are supported with both frame types.

Ethernet Version 2

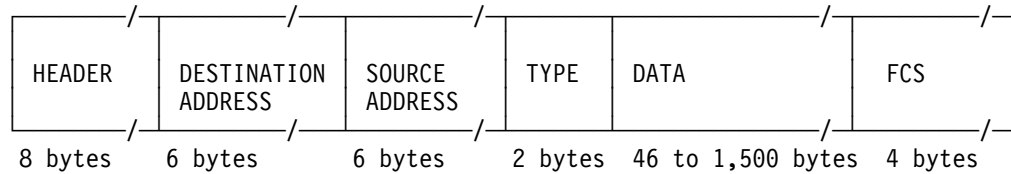

Table 12-1. Ethernet V2 Frame

Field Name	Bytes	Field Function
HEADER	0 - 7	Fixed bit sequence to identify the start of a frame.
DESTINATION ADDRESS	8 - D	Only 48 bit addresses are supported by Ethernet V2.
SOURCE ADDRESS	E - 13	Address of the source Ethernet adapter for the frame.
TYPE	14 - 15	To identify the higher level protocol that is embedded within the Ethernet V2 frame. The types supported by the 3745 Ethernet are: X'800' IP X'806' ARP
DATA		The size of this field can vary from a minimum of 46 bytes to a maximum of 1500 bytes. Since the requirement is that the Ethernet V2 data field be at least 46 bytes any use of PAD characters will have to be carried out by the NCP.
FCS		A 4 byte frame check sequence is included at the end of an Ethernet frame.

IEEE 802.3 Frame

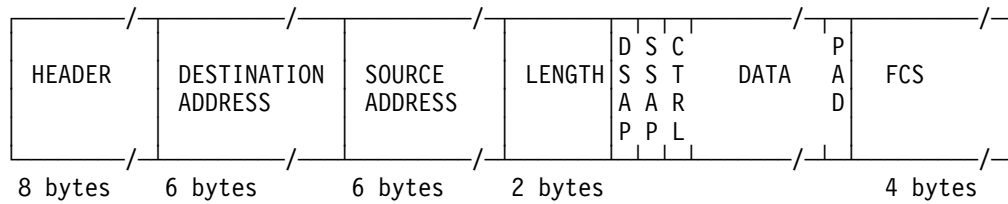

Table 12-2. IEEE 802.3 Frame

Field Name	Byte	Field Function
HEADER	0 - 7	Fixed bit sequence used for identifying the start of a frame. The last byte is the start frame delimiter.
DESTINATION ADDRESS	8 - D	Only 48 bit addresses are supported by the 3745 Ethernet.
SOURCE ADDRESS	E - 13	Address of the source Ethernet adapter for the frame.
LENGTH	14 - 15	Length from the next field to the end of the information. This value includes the DSAP, SSAP, CONTROL, and DATA fields. It does not include the PAD field.
DSAP	16	Destination Service Access Point. Bit 6 is the user defined address indicator. Bit 7 is the individual/group indicator.
SSAP	17	Source Service Access Point. Bit 6 is the user defined address indicator. Bit 7 is the command/response indicator.
CONTROL		May be a one byte or two byte field. For the type 1 frames used with connectionless protocols, the field will always be one byte. Only three types of frames are supported: Unnumbered information frame (x'03'), XID frame (x'BF'), and Test frame (X'F3').
DATA		Variable length field that contains the information portion of the frame. The length of the information must be within a range that allows the total size of the IEEE 802.3 frame data to less than the allowed maximum. For the 10 megabit 500 meter IEEE 802.3 standard, this value is the same as that for Ethernet V2 1500 bytes. Note however that the IEEE 802.2 header fields are counted as part of the data. So that the maximum size of a higher level protocol data unit that is embedded in an IEEE 802.3 frame will be less than the 1500 bytes allowed for an Ethernet V2 frame.
PAD		The size of an IEEE 802.3 frame must exceed a minimum value. For a 10 megabit 500 meter baseband implementation, this value is 64 bytes. The entire frame except for the PREAMBLE is included in this value. When the 18 byte length of the DA, SA, LENGTH, and FCS are subtracted, the 46 byte remainder is equivalent to the Ethernet V2 minimum packet size. If necessary the PAD field is included in an IEEE 802.3 frame to bring the frame up to the minimum size. The length of the PAD field is not included in the value in the LENGTH field.
FCS		A 4 byte frame check sequence is included at the end of an IEEE 802.3 frame.

ELA Microcode Description

ELA Microcode Functions

The ELA RAM Microcode provides:

- Interconnection between the control program and the EAC.
- Interconnection between MOSS and the EAC.
- Error handling.
- Loading the EAC Picocode.
- Problem determination items such as SIT, ESS services, EID.
- Handling of all of the SIT functions currently handled by the EAC picocode.
- Handling of early transmit status and error reporting to the control program to minimize the inter-packet gap.
- Handling a set of counters for certain Ethernet errors.

The ELA ROS Microcode provides:

- IPL of the ELA RAM Microcode
- Initialization of the ELA RAM Microcode
- Dump of the ELA RAM Control Storage (Microcode, control blocks,..).

ELA Microcode Structure

CSP Card

The CSP card provides:

- Interconnection to the IOC bus.
- Interconnection to the EAC card.
- JIB processor which includes:
 - The CSP ROS
 - Local Store registers
 - Control Storage (RAM)
 - Ping and Pong buffers
- External Registers (addressing for 32 registers).
- Address compare hardware.

Microcode Interrupt Levels

The CSP/JIB provides 8 interrupt levels for the microcode to use. Following are the functions positioned on these levels for the ELA:

- Level 0: Error processing, MOSS command processing
- Level 1:
 - NCP/MOSS commands (PIO IOH/IOHI, MIOH)
 - Cycle Steal (AIO)
- Level 2: EAC status
- Level 3:

- Receive command processing
 - Cycle steal initiation
- Level 7: Background, transmit, set mode, enable, disable, F4/F5, SIT, timer control.

Microcode Control Blocks in CSP Control Storage

The following types of control blocks are used by the microcode:

- ICB (Interface Control Block)

There are two ICBs for each line; one for each interface (transmit and receive). The ICBs contain items necessary for the microcode to perform the action in process. For example, the CSP and CCU addresses for cycle steal operation, operational flag bits, TA/TD of the command in progress, and so on.
- PSA (Parameter Status Area)

There are two PSAs for each line; one for each interface (transmit and receive). The PSAs contain the parameters obtained from the CCU for the command in progress and the Status after the command is complete.
- LCB (Line Control Block)

There is one LCB for each line. The LCB contains information about the line, such as the Set Mode data, Internal Box error status, line timers, and so on.
- Other control blocks include ones for MOSS and SIT commands, EAC control words, EAC data trace for SIT, ...

Internal Interconnections

As shown in “ESS Data Flow” on page 12-8, each ELA interconnects with the communication subsystem (CSS) and the MOSS via the IOC bus and the DMA bus.

CSP-to-IOC Bus

This connection is used for:

- Communication with the NCP (through the same IOH high level commands as the other HSS scanners)
- MOSS command exchange
- ELA IML
- Diagnostics.

The physical interconnection between the ELA CSP and the CCU is identical to that between the LSS CSP to the CCU (refer to Chapter 4, "Transmission Subsystem").

For board and card locations, see the *Maintenance Information Procedures Manual*.

NCP-ELA Microcode

The CCU uses IOH and IOHI to exchange data, commands and statuses with the ELA CSP in the same way as with the LSS, but cycle steal is not used when the EAC is running.

EAC to CSP

The physical interconnection between the EAC and the CSP is identical to that between the FESH and the CSP of the HSS.

For board and card locations, see *Maintenance Information Procedures Manual*.

Microcode to EAC

The picocode is loaded from the CSP in each layer of the EAC RAM at IML time.

The EAC-to-CSP interconnection is activated and controlled via external registers and control words (CW).

A CW is built by the CSP microcode and specifies the actions to be performed by the EAC.

The CW is cycle stolen by EAC, then executed.

The EAC informs the CSP microcode when the action is completed.

EAC to DMA Bus

This connection is used for direct CCU storage access and specifically:

- NCP buffer prefix exchange
- Data transfer between the Ethernet LAN and main storage

The physical interconnection between the EAC and the DMSW is identical to that between the FESH and the DMSW of the HSS.

Communication Scanner Processor (CSP)

The ELA CSP hardware is identical to that of the LSS CSP (refer to Chapter 4, "Transmission Subsystem" for details).

Ethernet LAN Coupler Card (EAC)

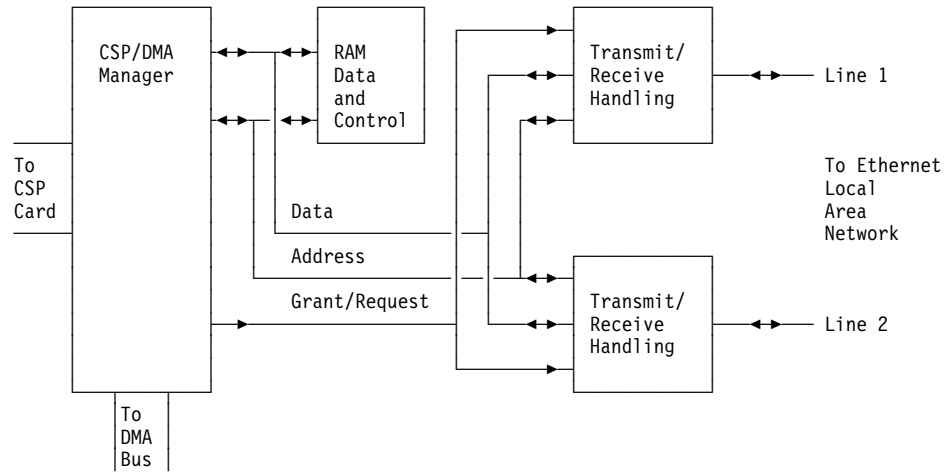

Figure 12-3. EAC Data Flow

The transmit/receive handling of the EAC is functionally organized in layers:

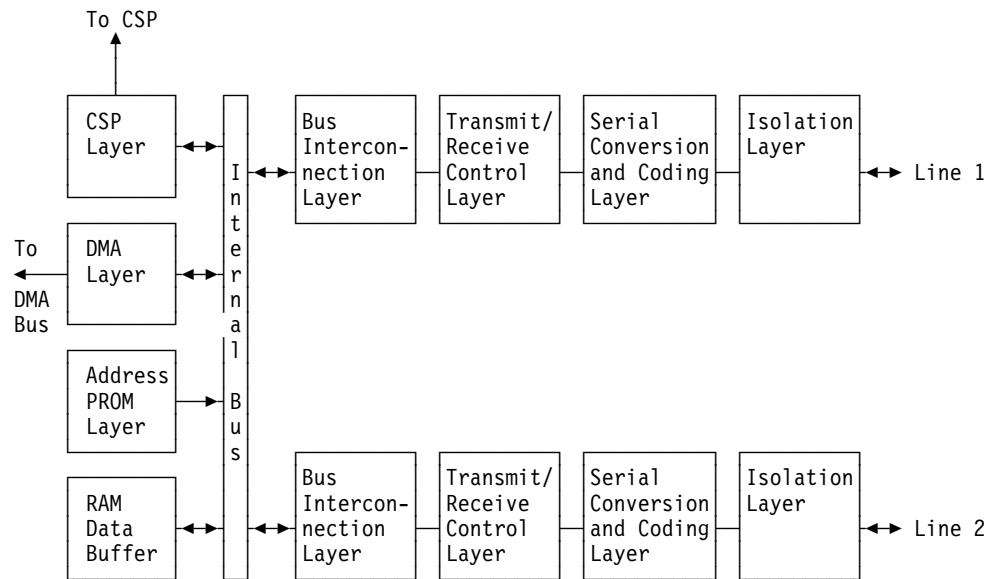

Figure 12-4. EAC Layers

CSP Layer

The CSP layer:

- Interconnects on one side with the CSP storage and microcode.
- Interconnects on the other side with the various EAC layers via CSP external registers and cycle steal operations.
- Handles the protocols of CSP external registers and cycle steal operations.
- Handles cycle steal requests from the CSP layer.

DMA Manager Layer

The DMA manager layer:

- Interconnects on one side with:
 - EAC RAM
 - Data buffers
- Interconnects on the other side with the DMA bus.
- Handles the DMA bus protocol.
- Performs data transfer from/to CCU main storage, to/from transmit/receive/data buffers.

Address PROM Layer

The address PROM contains:

- The 48 bit Universal Ethernet address for line 1.
- The 48 bit Universal Ethernet address for line 2.
- The one's complement of each of the above addresses.
- The addresses are read by the picocode and placed in the RAM where they are accessed by the CSP microcode.

Bus Interconnection Layer

The bus interconnection layer:

- Provides communication between the CSP layer and the transmit/receive control layer.
- Provides communication between the RAM and the transmit/receive control layer.
- Communicates with the bus arbitrator.

Transmit/Receive Control Layer

The transmit/receive control layer:

- Obtains data from the RAM and transfers it to the serial conversion for transmission to the line.
- Filters out frames that the control program does not support. If IP Dynamics is supported, this filtering process is made more flexible by using an Ethernet Type table provided by the control program by the Set Mode command.
- Receives data from the serial conversion layer and transfers it to the RAM.
- Provides status to the CSP layer after each transmit/receive operation.
- Generates CRC.
- Checks CRC.
- Checks network addresses.
- Synchronizes adapter with network.
- Checks receive frame lengths.

Serial Conversion and Coding Layer

The serial conversion and coding layer:

- Converts from parallel to serial data on transmit.
- Converts from serial to parallel data on receive.
- Converts to/from binary from/to differential Manchester code.

Isolation Layer

The isolation layer:

- Provides electrical isolation from the transceivers.

Reset EAC

All latches are reset, the DMA is disabled, the card is kept in 'freeze mode' (EAC not operational) until the CSP loads the microcode.

ELA Command Description

Once a command is received by the CSP it becomes 'outstanding'. It stays outstanding until the CSP sets a CCU level 2 interrupt to terminate the command.

The following commands do not create an 'outstanding command' condition:

- Halt
- Halt immediate
- Dump control blocks (no status)
- Dump control blocks (status)

These four commands are accepted even when there is an outstanding command and are used to terminate the outstanding command.

If a new command is received when there is an outstanding command, the new command is rejected (a CCU Level 1 interrupt request is set).

Set Mode

The Set Mode command is used to select and personalize the line. It is also used to either get a locally administered address from the control program and provide it to the ESS, or transfer the adapter Ethernet address (universally administered address) from the ESS.

The NCP IP address for the line is provided by Set Mode command. If the control program is supporting IP Dynamics, the Set Mode provides an Ethernet Type table to be used in filtering of frames being received.

Set mode must be the first command issued to a line. If another command is received before the Set Mode, it is rejected and a CCU level 1 interrupt request is raised. One exception to this rule exists: a Halt Immediate, issued before the Set Mode (for example when there is no outstanding command) will be accepted. It will, however, be ignored as there is no outstanding command.

Set Mode data includes:

1. NCP buffer information
2. Counter overflow limits
3. Split First Buffer specification
4. Type of address used
5. Locally Administered Address.
6. NCP IP address

A Set Mode command may only be issued to the even interface of a line. It will be rejected if issued to the odd interface. The Set Mode command may be issued at any time as long as there is no other command outstanding.

CSP Processing

1. Get the parameters from the CCU.
2. Save the line (interface) IDs, which are part of the parameters.
3. If ESS and NCP support IP Dynamics, get Ethernet Type table and provide it to the EAC picocode. Also, set the ESS in IP Dynamics mode so the table will be used for filtering incoming frames.
4. Get the set mode data from the CCU.

5. Initialize the CSP control blocks and the EAC with the set mode parameters from NCP.
6. Transfer the proper Ethernet address.
7. Build the command ending status and transfer it to the CCU.
8. Set a CCU level 2 interrupt.

Typical Ending Statuses

SCF	SES	LCS	Meaning
44	00	00	Set mode complete
00	00	D2	Command rejected
C4	00	00	Halt executed
00	00	See ¹	Internal box error

¹ = Refer to “Line Communication Status (LCS)” on page 12-30 for details.

Enable

The Enable Command is used to prepare the line for data transfer.

The EAC picocode will initialize the hardware so that it can accept a transmit or receive command.

The Enable must be issued to the even interface only. It will be rejected if issued to the odd interface. In addition the Enable must be executed before any data transfer commands are sent to the CSP.

Internal box errors that occur after completion of the Enable command, are stacked in the CSP and will be passed to NCP in the ending status of the next command.

The ESS microcode will run a 10 second timer waiting for the EAC to finish its Enable process. If the timer expires, an LCS of D0 will be returned as an internal box error because this is a picocode/hardware function only.

CSP Processing

1. Start an Enable timer.
2. Initialize the ECA initialization block for external loopback.
3. Initialize control blocks in EAC external RAM and then issue a DISABLE, INIT and START commands to the EAC to allow for an external loopback.
4. Perform the external loopback.
5. Check result of loopback. In case of errors, repeat the loopback up to 32 times.
6. Initialize the ECA initialization block for normal operation.
7. Initialize control blocks in EAC external RAM and then issue a DISABLE and INIT commands to the EAC.
8. Clear the ESS error and status counters.
9. Clear any counter overflow indications.
10. The ending status is built and transferred to the CCU.
11. A CCU level 2 interrupt request is set.

Typical Ending Statuses

SCF	SES	LCS	Meaning
44	00	9E	Enable complete
C4	00	00	Halt executed
00	00	F2	Connection not established
00	00	D2	Command rejected
00	00	See ¹	Internal box error

¹ = Refer to "Line Communication Status (LCS)" on page 12-30 for details.

Disable

The Disable command is used to stop the EAC and prevent it from receiving any more packets or being able to transmit any packets. The line is placed in the disabled state and an Enable command must be issued before the line can transfer data again.

A Disable may be issued to the even interface only. It will be rejected if issued to the odd interface.

The ESS microcode will run a 10-second timer, waiting for the EAC to finish its Disable process.

CSP Processing

1. Start the disable timer.
2. Issue a Disable command to the EAC and wait for an EAC interrupt.
3. The ending status is built and transferred to the CCU.

Typical Ending Statuses

SCF	SES	LCS	Meaning
44	00	9C	Disable complete
00	00	D2	Command rejected
00	00	See ¹	Internal box error

¹ = Refer to “Line Communication Status (LCS)” on page 12-30 for details.

Change

This command is used to update up to ten contiguous bytes of the Set Mode data.

The Change command is rejected if received on the odd interface or if it is sent to a line that has not received a Set Mode command.

CSP Processing

1. Get the parameters from the CCU.
2. Update the Set Mode data bytes as requested.
3. Initialize the CSP control blocks and EAC with the new data.
4. Build the ending status and transfer it to the CCU.
5. Set a CCU level 2 interrupt request.

Typical Ending Statuses

SCF	SES	LCS	Meaning
44	00	00	Change complete
00	00	D2	Command rejected
00	00	See ¹	Internal box error

¹ = Refer to “Line Communication Status (LCS)” on page 12-30 for details.

Transmit Data

The Transmit Data Command is used to transmit:

- Ethernet V2 frames
- IEEE 802.3 frames.

This command will be rejected if issued to the odd interface.

The entire frame must be contained in the first NCP buffer chain. When a buffer pointer of zero is detected in the buffer prefix area, the end of data for the frame has been reached.

CSP Processing

1. Get the parameters from the CCU.
2. Prepare a transmit control word for the EAC containing:
 - The buffer count from the PSA
 - The buffer offset from the PSA
 - The first transmit buffer address from the PSA.

Note: The buffer prefix length is forced to x'08' by the ESS.

EAC Card

3. Issue a Start Transmit command to the EAC. The EAC will enter in a transmit mode and then start processing the transmit buffer provided in the control word.

EAC buffer processing works as follows:

- If the first transmit buffer address is not zero and the NCP buffer count is not zero, then all data in the chain of NCP buffers is transmitted, until an NCP buffer link pointer of zero is detected.
 - If the first transmit buffer address is not zero and the NCP buffer count is zero, then the first buffer is skipped. Data in all buffers chained to the first is transmitted, until an NCP buffer link pointer of zero is detected.
 - For buffers subsequent to the first, the offset and count are taken from the buffer prefix and a prefix length of x'08' is used.
4. Build the ending status and transfer it to the CCU.
 5. Set a CCU level 2 interrupt request.

Typical Ending Statuses

SCF	SES	LCS	Meaning
46	00	00	Transmit started
00	00	D2	Command rejected
00	00	See ¹	Internal box error
10	00	F4	Ethernet error (LCAR)
C4	00	00	Halt executed

¹ = Refer to "Line Communication Status (LCS)" on page 12-30 for details.

Receive

The Receive Command is used to pass the address of the first buffer in a receive data buffer chain to the CSP and to place the CSP in receive mode.

CSP Processing

1. Get the parameters from the CCU.
2. Prepare a receive control word for the EAC containing:
 - The buffer count from the PSA
 - The buffer offset from the PSA
 - The first receive buffer address from the PSA.

Note: A Buffer Prefix Length of x'08' is used by the ESS.

3. Issue a Start Receive command to the EAC. The EAC will enter in receive mode where it is allowed to start receiving packets from the line.
4. Start a timer to wait for any received packets. This timer value will be internal to the microcode, but must be less than the NCP backup timer value used to wait for any command status.
5. If any statistical counters have overflowed, bit 7 of the SCF status will be set indicating this fact.
6. When an end of message interrupt is received from the EAC or the receive timer expires, build an ending status and transfer it to the CCU.
7. Set a CCU level 2 interrupt request.

Typical Ending Statuses

SCF	SES	LCS	Meaning
4C	00	00	End of frame, data stored
4D	00	00	End of frame and counters overflowed
00	00	80	Timeout, no packets received
01	00	80	Timeout and counters overflowed
00	00	D2	Command rejected
00	00	See ¹	Internal box error
C4	00	00	Halt executed

¹ = Refer to “Line Communication Status (LCS)” on page 12-30 for details.

Get Counters

The Get Counters command is used to pass the address of an NCP buffer to be used by the ESS to return error counter information. This command is issued by NCP in response to a counters overflowed status on a receive command (SCF bit 7 on) from the ESS. It may also be issued at other times when deemed necessary by NCP to retrieve the current set of counters.

CSP Processing

1. Get the parameters from the CCU.
2. Place the counters in the buffer provided.
3. Build an ending status and transfer it to the CCU. This status will include the 'Counter that Overflowed' status byte.
4. Set a CCU level 2 interrupt request.

Typical Ending Statuses

SCF	SES	LCS	Meaning
4C	00	00	Counter Data Stored
00	00	D2	Command rejected
00	00	See ¹	Internal box error
C4	00	00	Halt executed

¹ = Refer to “Line Communication Status (LCS)” on page 12-30 for details.

Halt

The halt command is used to terminate an outstanding command before it completes. The halt, service request and EOM bits are set in the SCF. Other status bits are not changed. Thus, the status will show any condition that existed at the time the halt was processed. Refer to the SCF bit description on page 12-29 for more details.

The following commands may not be Halted:

- Start Trace
- Stop Trace
- Dump control blocks (no status)
- Dump control blocks (status)

Any attempt to halt these commands will result in unexpected responses from the ESS.

A halt to any of the following commands is ignored:

- Set Mode
- Disable
- Change

However, it is not an error to issue a halt when one of these commands is in process.

If no command is active in the CSP when a halt is issued, the halt becomes the outstanding command. Activity on the line is halted; an ending status is built for the halt command and sent to the CCU.

Consecutive halts with no intervening CCU level 2 interrupt will cause a CCU level 1 command reject interrupt from the ESS.

It is possible that status for an outstanding command has been built and sent to the CCU and a CCU level 2 interrupt has been set at the time a Halt command is issued, but the NCP has not yet honored the interrupt (the line ID is still waiting in the CSP).

In this case, the CSP will invalidate the queued line ID. A new line ID, formed by adding X'80' to the low halfword of the special LNVN address, replaces the old ID. The halt will then become the outstanding command.

CSP Processing

1. Make the halt the outstanding command if there is no other command in process.
2. Perform the defined operation.
3. Update the status area and transfer it to the CCU.
4. Raise a CCU level 2 interrupt.

Halt Immediate Command

The halt immediate (Halti) command is used to terminate an outstanding command and does not require a CCU level 2 status interrupt from the ESS.

In general, the halt immediate command may be issued to the CSP at any time, whether or not there is an outstanding command. However, the following commands may not be Halti'ed:

- Start Trace
- Stop Trace
- Dump control blocks (status)

Any attempt to Halti these commands will result in unexpected responses from the ESS.

A Halti to the following command is ignored:

- Dump control blocks (no status)

However, it is not an error to issue a Halti when this command is in process.

The Halt Immediate command requires no parameters and builds no status; therefore, no PSA transfer to or from CCU storage occurs.

The Halt Immediate command does not create an outstanding command condition in the CSP. Therefore, the control program may issue a Halti and follow it immediately with another command.

The CSP will ignore a Halti if it is issued when there is no outstanding command.

If a command is outstanding to both the CCU and CSP at the time the Halti is issued, the CSP will:

1. Perform the defined operation.
2. Discard any pending status.

Parameter/Status Area

The control program residing in the CCU (NCP) provides a fixed-length field of CCU storage for each line interface serviced by high-level commands.

The parameter/status area is a field reserved in CCU storage by the NCP.

It is used to transfer the control and status information between the control program in the CCU and the CSP.

Information is transferred using cycle steal under control of the CSP.

The parameter/status area is made up of:

1. A parameter area (16 bytes long)
2. A status area (12 bytes long).

The parameter area is used to pass to the CSP, parameters required in the execution of a command.

The status area is used to pass ending status to the control program in the CCU.

Upon receipt of a start line or start line initial instruction, the CSP gets information from the parameter area, executes the command, puts ending status into the status area, and requests a CCU level 2 interrupt.

Refer to "Parameter/Status Area Layout" on page 12-29 for field description.

Input/Output Instruction Formats

The CCU communicates with the CSP via input/output halfword (IOH) or input/output halfword immediate (IOHI) instructions sent on the IOC bus at TA time.

TA Field Byte 0

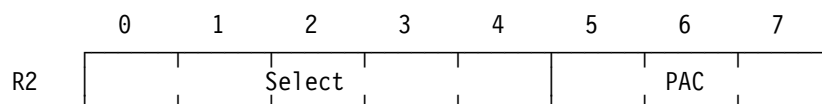

TA Field Byte 1

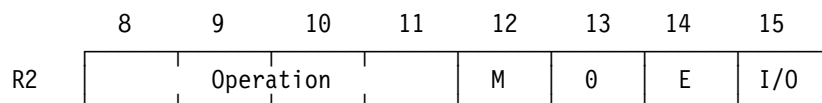

TD Field Byte 0

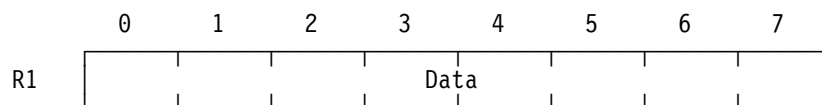

TD Field Byte 1

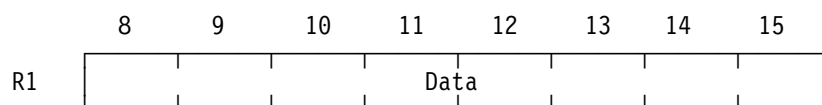

I is the 16-bit immediate data field of the IOHI instruction.

TD fields:

The contents of these two bytes depend on the instruction (as indicated in the operation field of TA1). For example, if the operation is start line or start line initial, TD byte 0 is the command to be performed by the scanner, and TD1 contains the line interface address. Refer to the description of each operation for a definition of the TD fields.

IOH/IOHI Instruction Summary

IOH/IOHI Code	Description
00	Start line
01	Get line ID
10	Start line initial
11	Get error status
20	Set line vector table high
21	Get command reject status
30	Set line vector table low
31	Get microcode check
50	Set special line vector table high
60	Set special line vector table low
F2	Automatic dump

Start Line

The start line (TA byte 1=X'00') is issued to the CSP when a new command is to be started and the location of the parameter/status area has already been established.

Get Line ID

The get line ID (TA byte 1=X'01') is issued to all CSPs (select bits 2 and 3 are ON to indicate a 'broadcast address') when servicing a CCU level 2 interrupt.

Start Line Initial

The start line initial (TA byte 1=X'10') is issued to the CSP when a line operation is to be started and it is necessary to establish the location of the parameter/status area.

Get Error Status

The get error status (TA byte 1=X'11') is issued to the CSP in response to a CCU level 1 interrupt request. This interrupt indicates a CSP program or hardware error.

Set Line Vector Table High

Set line vector table high (TA byte 1=X'20') indicates to the CSP its entry into the line vector table (LNVT) in CCU storage. More specifically, the NCP passes the high byte LNVT address for the first interface supported by a given CSP.

Get Command Reject Status

Get command reject status (TA byte 1=X'21') is issued to the CSP after the CCU has received a command reject error status to gather more information about the command reject.

The CSP responds with a two-byte status which identifies the command in process followed by the command that overlapped it. There is no default value for TD.

Set Line Vector Table Low

Set line vector table low (TA byte 1=X'30') indicates to the CSP its entry into the line vector table (LNVT) in CCU storage. More specifically, the NCP passes the low halfword LNVT address for the first interface supported by a given CSP.

Get Microcode Check

Get Microcode Check (TA byte 1=X'31') is issued to the CSP after the CCU has received a type 3 error status with bit 4 set (microcode check) to get information about the microcode check.

The CSP responds with a two-byte field containing the identification of the checker in the second byte. The following is a list of the ELA microcode checks that can be returned:

Status	Meaning
0001	Double queuing of an ICB pointer
0003	Fast get line ID not active
0008	Branch to X'8000'
000A	Branch to X'A000'
000B	Branch to X'B000'
000C	Branch to X'C000'

Set Special Line Vector Table High

Set special line vector table high byte (TA byte 1=X'50') is used to modify the location of the special line vector table (SLNVT).

Set Special Line Vector Table Low

Set special line vector table low halfword (TA byte 1=X'60') is used to modify the location of the special line vector table (SLNVT).

Automatic Dump

Automatic dump (TA byte 1=X'F2') is used to cause a scanner dump.

As a result of this instruction, the ELA sets a CCU level 1 interrupt and returns a status that causes NCP to request a scanner dump from MOSS.

CSP Addressing

The CSPs associated with the possible eight ELAs installed in a 3745 are assigned the addresses of the first eight line adapters (LA) on the LA board 1 (TSSB board).

These addresses are used in the input and output instructions to select individual ELA adapters. In addition, all CSPs respond to a general broadcast address which is used in the get line ID instruction during auto-selection.

Parameter/Status Area Layout

The configuration of the parameter/status area differs from command to command. However, the fields which appear in multiple commands are always found in the same PSA location.

A layout of an ELA PSA follows.

Trace Correlation Counter	Modifiers	0
Offset 1	Offset 2	1
Buffer 1 Count		2
First Buffer Pointer 1		3
		4
		5
		6
First Buffer Pointer 2		7
SCF	CCMD	8
SES	LCS	9
Residual Count / ELCS	IP Dynamics mode (Set Mode) / Last Buffer Pointer	A
Last Buffer Pointer		B
		C
		D
		E
		F

Figure 12-5. General ELA PSA Layout

Status Control Field (SCF)

This byte contains information which describes the progress of the operation being executed.

Bit 0 1 2 3 4 5 6 7	Meaning
x	Halt
. x	Service request
. . x	Unused
. . . x	Hardware error LCAR
. . . . x	Data stored
. x . . .	End of message (EOM)
. x . .	Data transmitted occurred
. x	Counters overflowed

Current Command (CCMD)

This byte identifies the CSP command to which this status applies.

Secondary Status (SES)

Unused

Line Communication Status (LCS)

This byte contains status applicable to the line being serviced. The byte is divided into two fields as shown below:

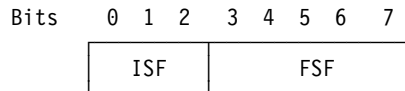

ISF = Initial status field
 FSF = Final status field

Initial Status Field (ISF) Bit Definition

The ISF (LCS bits 0 - 1) indicates essentially the type of line control that is used. The ISF is decoded as follow:

ISF	FSF	
0 1 2	3 4 5 6 7	Meaning
1 0 0	Special status
1 1 0	Internal box error
1 1 1	Hardware error

Special Status: See paragraph "Initial Status = B'100' (Special)" on page 12-31 for more explanation.

Internal box error: See paragraph "Initial Status = B'110' (Internal Box Error)" on page 12-31 for more explanation.

Hardware error: See paragraph "Initial Status = B'111' (Hardware Error)" on page 12-34 for more explanation.

Final Status Field (FSF)

The FSF (LCS bits 3 - 7) gives further status information. The encoding is based upon the ISF configuration and is defined as follows:

Initial Status = B'100' (Special)

ISF			FSF				Meaning
0	1	2	3	4	5	6 7	
1	0	0	0	0	0	0 x	Time out (nothing received)
1	0	0	1	1	1	0 x	Disconnected
1	0	0	1	1	1	1 x	Connected

Initial Status = B'110' (Internal Box Error)

ISF			FSF				Meaning
0	1	2	3	4	5	6 7	
1	1	0	0	0	0	0 0	AIO error
1	1	0	0	0	1	0 0	CSP interconnection error
1	1	0	0	0	1	1 0	EAC failed to answer
1	1	0	0	1	0	0 0	EAC internal error
1	1	0	0	1	0	0 1	Transmitter timeout error
1	1	0	0	1	0	1 0	Storage error
1	1	0	0	1	0	1 1	Transmit overrun
1	1	0	0	1	1	1 0	Receive buffer error
1	1	0	1	0	0	0 0	No interrupt from EAC
1	1	0	1	0	0	1 0	Command rejected (See Note 1)
1	1	0	1	0	1	0 0	Trace already active
1	1	0	1	0	1	1 0	Transmit buffer error
1	1	0	1	1	0	0 0	Invalid level 2 interrupt
1	1	0	1	1	0	1 0	Underflow
1	1	0	1	1	1	0 0	SCTL/DMA/DMSW error (See Note 2)
1	1	0	1	1	1	1 0	Overflow
1	1	0	1	1	1	1 1	Collision

Notes:

1. An extended LCS code (ELCS) is generated. Refer to "Extended Line Communication Status (ELCS) For LCS X'D2'" on page 12-32 for details.
2. An extended LCS code (ELCS) is generated. Refer to "Extended Line Communication Status (ELCS) For LCS X'DC'" on page 12-33 for details.

Initial Status = B'110' (Internal Box Error): The code is the value of the LCS bits 0 to 7 (fields ISF, FSF).

Code Description

C0	AIO error indicates a hardware error during an adapter-initiated operation (cycle-steal).
C4	CSP/EAC interconnection hardware error.
C6	No answer to a microprogram initiated operation to the EAC.
C8	EAC hardware error detected by the EAC.
C9	Transmitter time out error. It indicates that the transmitter has been active longer than the time to send the maximum length packet. It occurs when 1519 bytes have been transmitted. The entire packet will continue to be transmitted unless a failure occurs.
CA	Internal storage access in the EAC did not receive a ready signal from the EAC hardware when trying to access memory.
CB	This indicates that neither of the two internal EAC transmit buffers is free to be used by DMA for the transmit command issued.
CE	The EAC hardware receive buffers are defined large enough to hold the maximum expected receive frame of 1518 bytes. If a receive frame is received greater than 1518 bytes, the EAC picocode will detect this and report this condition to the microcode which will result in a counter increment.
D0	The EAC has failed to respond to a microcode request.
D2	The command issued by the control program has been rejected by the CSP. An extended LCS code (ELCS) is generated. Refer to "Extended Line Communication Status (ELCS) For LCS X'D2'" for details.
D4	A scanner internal trace is already running on this interface.
D6	EAC does not find an end of packet flag in the current internal EAC buffer and does not own the next buffer.
D8	An unexpected CSP level 2 interrupt from the EAC has occurred.
DA	Indicates that the EAC transmitter has truncated a message due to data late from the EAC internal memory.
DC	SCTL/DAM/DMSW type error. An extended LCS code (ELCS) is generated. Refer to "Extended Line Communication Status (ELCS) For LCS X'DC'" on page 12-33 for details.
DE	EAC receiver lost part or all of a packet because it could not store it into an EAC buffer before the front end internal silo overflowed.
DF	Collision error indicates that the collision input to the EAC failed to activate within 2 microseconds after a EAC-initiated transmission was completed.

Extended Line Communication Status (ELCS) For LCS X'D2': When the LCS = X'D2', additional statuses for command reject may be found in byte 4 of the status area. These additional statuses are:

Code Description

01	Line not enabled, common command
02	SIT buffer not available
03	Receive command received but line not enabled
04	Receive command received not using NCP type buffers
05	Invalid command received on receive interface
06	Transmit command received but line not enabled
07	Transmit command received not using NCP type buffers
08	Invalid command received on transmit interface

- 09** Transmit type command to receive ICB
- 0A** Halt received with no command in progress and line disabled
- 0B** Set Mode addressed to a line other than the first 2 in this ESS
- 0C** Transmit frame longer than 1514 bytes
- 0D** NCP receive buffer shorter than 1518 bytes.
- 0E** F5 issued when no command is in progress.

Extended Line Communication Status (ELCS) For LCS X'DC': When the LCS = X'DC', additional statuses, as with internal box errors, may be found in byte 4 of the status area. These additional statuses are:

Code Description

- 02 (a)** SCTL/DMA internal error
- 04 (e)** SCTL/DMA interconnection error
- 06** Combination of (f) and (g)
- 08 (3)** DMA time out on write
- 0A (1)** DMA interconnection error in write
- 10 (c)** SCTL/DMA storage protect/address exception
- 12 (b)** SCTL/DMA logical error
- 14 (f)** DMSW main bus parity check
- 16** Combination of (f) and (h)
- 18 (4)** DMA time out on read
- 1A (2)** DMA interconnection error on read
- 22 (d)** Storage unrecoverable error/SCTL internal error
- 24** Combination of (e) and (f)
- 28 (g)** DMSW parity check on primary/secondary bus
- 2A (5)** DMA bus driver fault
- 34** Combination of (e), (f) and (g)
- 3A (6)** DMA burst count error
- 44** Combination of (2), (e), (f) and (g)
- 4A (h)** DMSW driver fault
- 5A** Combination of (1), (e), (f), and (g)
- 6A** Combination of (2) and (g)
- 7A** Combination of (2) and (h)
- 9A** Combination of (5), (e), (f) and (g)
- AA** Combination of (6) with any of (a) through (h)
- BA** Combination of (1) through (6) with any of (a) through (h) which are not listed above.

Initial Status = B'111' (Hardware Error)

ISF	FSF	Meaning
0 1 2	3 4 5 6 7	
1 1 1	1 0 0 1 0	Connection not established
1 1 1	1 0 1 0 0	Loss of carrier

The code is the value of the LCS bits 0 to 7 (fields ISF, FSF).

Code Description

- F2** During the Enable command process, the ESS will perform an external loopback to determine if a connection to the LAN is made. Any internal box errors will be reported as normal. But, all other errors that occur during the loopback will result in this F2 LCS. These include excessive retries on transmit, late collisions, CRC errors, framing errors, and missed packets.
- F4** This is set when the carrier input to the EAC goes false during a transmission. This is a transmit error. No retries have been done on the packet.

Note: In all cases of Internal Box Errors and Hardware Errors:

- The line is disabled by the CSP.
- The command on the failed interface is ended. LCS contains the error and a level 2 interrupt request is raised to the CCU.
- The command on the other interface is cleared without any ending status nor level 2 interrupt request to the CCU.

After such an error the only commands that will be accepted on the line are set mode or enable.

Residual Count

This byte indicates the number of unused bytes remaining in the last buffer used.

Last Buffer Pointer

This three-byte address points to the last buffer used during receive operations.

Data Management

The exchange of information between the NCP and the ELA microcode (Parameters, statuses, and so on) is done through cycle steal.

In receive or transmit, the parameters are used by the microcode to build the control word (CW). The CW allows the EAC hardware to start handling the frame exchange in receive or transmit.

The microcode builds the status to be sent to the NCP:

- After the completion of a transmit or receive command,
- At the end of the NCP buffer chain detected by the EAC, and before the reception of a complete frame to request a buffer for the EAC
- At buffer request from the EAC

- When an error is detected in the EAC adapter.

The microcode issues one single request to the EAC to manage the receive line interface and the transmit line interface.

Error Detection and Reporting

Program/Hardware Checks

In addition to the program/hardware errors reported in the command status via level 2 interrupts, the CCU may be notified by a CCU level 1 interrupt that a program or hardware check occurred.

To obtain the error information, the control program issues a get error status instruction, which transfers a two-byte error status to the CCU.

The control program also resets the check and the interrupt, and performs the recovery actions. The following conditions may cause a level 1 program or hardware check:

1. CCU/ELA problems:
 - IOH/IOHI instruction not supported.
 - IOH/IOHI rejected because there is already an outstanding command on the interconnection. For example, a second transmit command has been sent while a transmit command is already outstanding.
 - IOH/IOHI rejected because a set mode command has not yet been received for that line.
 - Abnormal conditions detected during I/O operations on the IOC bus. These errors may be detected by the CCU or by the ELA. Errors are related to CCU storage and address checks, invalid sequences, and timed-out IOH/IOHI instructions.
2. ELA problems:
 - Invalid interrupts.
 - Microcode-detected program failures. (These set the microcode check bit in the error status and cause the NCP to issue a get microcode check instruction.)
 - CCU level 2 interrupt stack overflow.
 - CSP or EAC hardware check (for example parity or address check).

If the check is not related to a particular line, the CSP microcode builds the error status, freezes the EAC, and waits for the get error status IOH.

For some severe errors, the CSP enters the disconnect/stop environment and ignores all IOH instructions generated by the NCP. Re-IML of the CSP microcode is required to return to an operational state.

Refer to "Error Status" on page 12-42 for the error status description.

Hardware Error Detection and Reporting

Two types of error:

- DMA and modem interface errors which raise the level 2 interrupt to the CSP.
- Errors which raise the level 0 interrupt to the CSP.

Internal Box Error (IBE) Reporting

The internal box errors generate box event records (BERs). For details on BERs, see chapter 11.

The IBEs can be divided into three categories:

1. CSP and EAC internal errors or events (similar to the errors defined for the CSP/FES in the LSS):
 - Adapter interconnection check
 - CSP/EAC interconnection error
 - EAC failing to answer
 - Transmitter error
 - Invalid interrupt from EAC
 - Command rejected
 - Trace already active
 - EAC internal error
 - EAC hardware not ready
 - AIO error
 - Frame greater than 1518 bytes
 - Collision error
 - EAC receiver lost part or all of a packet
 - Internal EAC transmit buffers not free
2. DMA errors detected by the EAC:
 - DMA parity error during write or read
 - DMA time out during write or read
 - DMA bus driver fault
 - DMA burst count error
 - DMA interconnection errors for improper DMA tag sequence.
3. Errors detected in the SCTL/switch cards:
 - Storage internal error
 - SCTL internal error
 - DMA internal error
 - DMA logical error
 - DMA storage protect/address exception
 - DMA interconnection error in read or write (a)
 - DMSW parity check main bus (b)
 - DMSW parity check primary/secondary bus (c)
 - DMSW driver fault. (d)

Notes:

1. The following errors can occur concurrently:
 - a and b
 - b and c
 - b and d
 - a, b, and c
2. All the errors listed above are reported to the NCP via a level 2 interrupt and associated status area as an LCS and ELCS code (refer to “Line Communication Status (LCS)” on page 12-30, “Extended Line Communication Status (ELCS) For LCS X'D2” on page 12-32, and “Extended Line Communication Status (ELCS) For LCS X'DC” on page 12-33 for codes description).

Error Detection and Reporting

3. The SCTL/switch errors and the EAC DMA interconnection errors are mutually exclusive. There is no double-reporting of errors.

DMA Interconnection Errors Detected by EAC (Register X'10')

DMA Tag Sequence

The EAC circuitry monitors the sequence of the DMA interconnection signals from the SCTL/switch card.

An error is reported when the tag sequence does not occur properly.

DMA Data Bus Parity Checker

This parity checker verifies the validity of the data received/sent, from/to the DMA data bus byte 0 and byte 1 by the EAC.

DMA Time out

One hardware timer is implemented to detect possible time out conditions on the DMA bus.

The duration of the timer is in the range of 100 ms to cover a complete transfer operation on the DMA bus.

DMA Burst Count Checker

This checker verifies that the transfer is successfully completed on the DMA bus when the burst count in the EAC reaches zero.

SCTL/Switch Card Detected Errors Reported by EAC

The SCTL-DMA card and the switch cards have internal checkers which detect the following error conditions which may occur during a DMA transfer initiated by an ELA (see the figure 'Line Error Hexadecimal Code' next):

Line Error Hexadecimal Code	SCTL-DMA/Switch Error Conditions								
	a	b	c	d	e	f	g	h	i
0		Normal mode (no error)							
1	x								
2		x							
3			x						
4				x					
5					x				
6						x			
7							x		
8								x	
9									x
A					x	x			
B						x	x		
C						x		x	
D									
E									
F					x	x	x		

Figure 12-6. Line Error Hexadecimal Code

- SCTL error detection:
 - a. DMA internal error
 - b. DMA logical error
 - c. DMA storage protect/address exception error
 - d. Storage unrecoverable error or control error
 - e. DMA interconnection error.
 - Switch card error detection:
 - f. DMSW parity check main bus
 - g. DMSW parity check primary/secondary bus
 - h. DMSW DMA driver fault
 - i. Not used

Error Detection and Reporting

The error conditions just described are encoded by the SCTL-DMA card and the switch card, and reported on 4 x SCTL/DMSW error lines which go from the DMSW card to the EAC card as shown in the following figure:

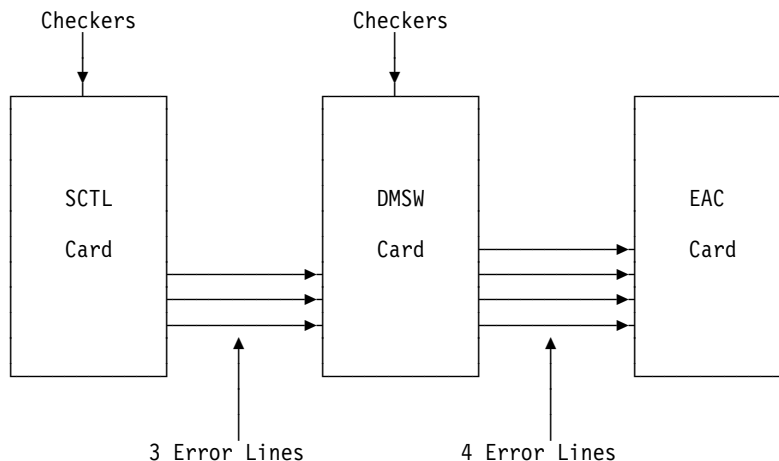

Reporting

Reporting of DMA errors is done by issuing a level 2 interrupt to the CSP. The nature of the error is set into an LCS/ELCS (refer to "Line Communication Status (LCS)" on page 12-30 and "Extended Line Communication Status (ELCS) For LCS X'D2'" on page 12-32 for code description).

When any of the above checkers becomes active:

1. The hardware:
 - Stores the corresponding error condition in an error register X'10' and CSP storage.
 - Interrupts the CSP microcode.
2. The CSP microcode
 - Stops the transmit and receive operations in process.
 - In case of transmit, puts the transmit data line at mark.
 - In case of receive, stops the receive command.

DMA/SCTL Errors

They are reported by the EAC through a level 2 interrupt and then both interfaces are disabled by the microcode.

The CSP microcode fills the LCS field of the PSA status with a status byte giving the reason for the error (refer to "Line Communication Status (LCS)" on page 12-30 and "Extended Line Communication Status (ELCS) For LCS X'DC'" on page 12-33 for code description).

The microcode then raises CCU level 2 interrupt.

Line interfaces are started again by the CSP microcode when the NCP sends the proper command sequence.

CSP Interconnection Errors

The CSP communicates with the EAC through the external registers located in the EAC (register range X'0D' to X'17').

The EAC completes the operation with the 'acknowledge' signal to the CSP if no error conditions were detected.

The EAC monitors the CSP interconnection for the following errors:

- Interconnection error signal from the CSP
- Bidirectional cycle steal data bus parity error
- External register address and select out parity error
- Data out odd parity error during an external register write operation.
- External register address invalid.

If an error occurs in the external register address because of a parity error or because the external register does not exist in the EAC, the 'acknowledge' signal is not sent to the CSP.

Also, if the data bus parity is incorrect during an external register write, the 'acknowledge' signal is not sent to the CSP.

When 'acknowledge' is not returned to the CSP by the EAC, the CSP sets the adapter interconnection check bit ON (external register X'03' bit 6 = 1) and terminates the operation.

The EAC does not report any error condition.

Parity errors occurring on the cycle steal interconnection can be detected by the EAC or by the CSP.

If the EAC detects a parity error on the data bus during a cycle steal write, the EAC sets a level 2 interrupt to the CSP with the CSP interconnection error status set after completing the operation.

The parity checking on the cycle steal address bus and the CSP data bus during a cycle steal or external register read operation is performed by the CSP.

When the CSP detects a parity error, the CSP sets the adapter interconnection check in the CSP register X'03' and activates the 'cycle steal error' line.

When the EAC detects this signal, the cycle steal operation ceases and the EAC activates a level 2 interrupt to the CSP.

The CSP interconnection error bit is set ON in the EAC external register X'10'.

Detection of this error causes a level 2 interrupt to the CSP.

If an NCP transmit or receive operation is in progress, it continues until the CSP microcode stops reception of data for the receive command, or stops transmission of data and sets the transmission line to mark.

EAC Internal Checkers

Data Parity Checkers

All the microcode (DMA layer, CSP layer) and data are checked for parity when the EAC internal buffers are read or written.

Reporting

When any of the above checkers becomes active:

- The EAC:
 - Stores the corresponding error condition in an error register.
 - Interrupts the CSP microcode at level 0.
- The CSP Microcode:
 - Provides a level 1 status to the control program.

Error Status

The error status is provided as the LA or L-STAT field in some ESS 08 type BERs. Refer to Chapter 11.

Four types of error may be reported:

- Type 1** Error detected by the CCU during PIO. A halt is send to the CSP, which results in a CCU or MOSS level 1 interrupt.
- Type 2** Error detected by the CCU during AIO. A halt is send to the CSP, which results in a CCU or MOSS level 1 interrupt.
- Type 3** Internal logical errors detected by the CSP microcode. A CCU level 1 or MOSS level 4 interrupt is set.
- Hard Stop** A CSP microprocessor check has been encountered. The CSP hardware responds with the error status.

The following tables show the detailed responses that may be presented to a get error status command:

Error Status Byte 0

Bit 0123 4567	Type 1	Type 2	Type 3
x... ..	R/W (IOH)	R/W (AIO)	Always ON
.x..	I/O bus check	I/O bus check	Invalid level 0 int.
..x.	Not used	Cycle steal grant	Invalid level 1 int.
...x	I/O bus tag I/O	I/O bus tag I/O	Invalid level 2 int.
.... x...	Halt	Halt	Microcode check
.... .x..	TA	Not used	CS/CCU L2 stack overf.
.... ..x.	TD	TD	Reject: command on cmd
.... ...x	Not used	Not used	Disconnect state

Error Status Byte 1

Bit 0123 4567	Type 1	Type 2	Type 3
x...x..	TA select Not used	Not used Cycle steal select	Command reject Invalid output IOH type
..x.x	Not used Not used	Not used Line interface address bit 0] See note below
.... x...x..	Not used Not used	Line interface address bit 1 Line interface address bit 2	
.... ..x.x	Not used Invalid input IOH	Line interface address bit 3 Line interface address bit 4	
.... ...x			
.... ...x			

Note: Next comes the decoding of bits 0 to 7 when command reject occurs.

Bit 0123 4567	Normal Command Reject	Trace Command Reject	Invalid Output IOH
x...x..x.x	Command reject Always OFF	Command reject Always ON Not used Not used	Always OFF Invalid output IOH Not used
.... x...x..x.x] Line interface address (0 to 3F)] Slot number (0 to F)] Line interface address (0 to 1F)

Error Detection and Reporting

Hard Stop Error Status (Detected by CSP Hardware)

Byte 0

Bit 0 1 2 3 4 5 6 7	Meaning
* * * * *	Not used
. x . .	Control store data check
. x .	LSR or external register parity check
. x	Internal check

} Only if processor
check

Byte 1

Bit 0 1 2 3 4 5 6 7	Meaning
x	Unexpected adapter acknowledgment
. x	Control store write data check
. . x	Processor check
. . . x	External register address check
. . . . x	Control store address check
. x . . .	LSR address check
. * *	Not used

Diagnostic Facilities

Refer to the *3745 Diagnostic Descriptions, SY33-2059*, for more details.

Problem Determination Aid

The following tools are provided to help define which area is failing:

1. Scanner interface trace (SIT) and checkpoint trace
2. ESS interface display (EID).
3. LSS functions from the MOSS service menu (see *Service Functions*, SY33-2069).

Microcode Service Aid

The EAC registers, the microcode RAM locations and the external data control RAM locations can be accessed, using the following facilities (See *Service Functions*, and *Advanced Operations Guide*, SA33-0097):

1. Alter/display
2. CSP address compare
3. CSP dumps.

These facilities, invoked from the operator console, help in analyzing/modifying the contents of the ELA storage and registers (CSP and EAC).

Programming Support for Problem Determination

It includes, as for LSS microcode:

1. Error detection
2. Error collection
3. Error reporting.

Types of errors tracked are:

- CSP/IOC bus interconnection errors
- CSP internal errors
- CSP/EAC interconnection errors
- DMA/SCTL/Switch errors
- EAC errors
- EAC-to-line interface errors.

NCP Buffer Prefix Validity Checking in Receive

This test is performed by the microcode for the first buffer only, by using the parameters coming from the PSA.

SIT Trace

The scanner interface trace (SIT) traces the address and control field, and up to 252 data bytes of each frame transmitted or received by the EAC card.

For the CSP, the NCP commands and the CCU IOH commands are also traced to provide a listing of the command and data transmission sequence for the line.

Problem Determination Aid

List of Abbreviations

A	ampere	CBC	controller bus coupler
AC	1) alternating current 2) address compare	CBTRA	controller bus and token-ring adapter
ACK	affirmative acknowledgment (BSC)	CBSA	controller bus and service adapter (CBSP+CBC+TIC3)
ACPW	ac power box	CBSP	controller bus and service processor
ACUN	access unit (token ring access unit such as the IBM 8228)	CBx	FRU name of circuit breaker number x
AC1	ac power box (ACPW) installed in position 1 of the 3746-900	CCITT	Comite Consultatif International Telegraphique et Telephonique
AC2	ac power box (ACPW) installed in position 2 of the 3746-900	CCU	central control unit
AFD	airflow detector	CCW	channel command word
AIO	adapter-initiated operation	CD	carrier detector (signal)
ARC	active remote connector	CDF	configuration data file
ASCII	American National Standard Code for Information Interchange	CDG	concurrent diagnostic
AUI	access unit interface	CDS	configuration data set (NCP/EP)
BASA	basic board A	CE	customer engineer
BASB	basic board B	CEPT	Comite Europeen des Postes et Telecommunications
BASC	basic board C	CLDP	controller load/dump program
BAT	basic assurance test	CLP	communication line processor
BATRY	FRU name of the battery	CMSA	CCU/MOSS status register A
BCCA	buffer chaining channel adapter	CMSB	CCU/MOSS status register B
BCLE	buffer control list element	CMSC	CCU/MOSS status register C
BER	box event record	CNM	communication network management
BPC1	FRU name of the bus propagation card to replace the CAL card	CO/CS	contact operate / contact sense
BPC2	bus propagation card to replace the TRM card	CP	1) communication processor 2) control program
bps	bits per second	CPN	customer problem number
BSC	binary synchronous communication	CPx	FRU name of circuit protector number x
BTLC	branch trace level control (register)	CRP	check record pool
CA	channel adapter	CRU	customer replaceable unit
CAB	channel adapter board	CS	1) cycle steal 2) communication scanner 3) connectivity switch
CADR	FRU name of the channel adapter driver receiver card	CSC	1) FRU name of the scanner for medium-/low-speed lines 2) connectivity switch cable
CAL	FRU name of the channel adapter logic card	CSCE	connectivity switch cable extension
CADS	channel adapter data streaming	CSCW	cycle steal control word
CAMPOR	CA MOSS power-ON-reset (register)	CSG	cycle steal grant
CARST	CA reset (register)	CSGH	cycle steal grant high
		CSGL	cycle steal grant low

CSP	FRU name of the communication scanner processor associated with the FESH card for high speed lines (CSC scanner for the medium-/low-speed lines)	FAN1	FRU name of the power supply box fan
CSR	cycle steal request	FAN2	FRU name of the logic box fan
CSRH	cycle steal request high	FCC	Federal Communications Commission
CSRL	cycle steal request low	FDD	FRU name of the flexible disk drive
CSS	control subsystem	FE	field engineering
CTS	clear to send (signal)	FESH	FRU name of the front-end scanner (high-speed)
dc	direct current	FRU	field-replaceable unit
DCAF	Distributed Console Access Facility	ft	foot
DCDP	dc distribution and protection box	GPT	generalized PIU trace
DCE	data circuit-terminating equipment	GTF	generalized trace facility
DCPW	dc power box	HCS	Hardware Central Service
DCREG	FRU name of the dc regulator card	HDD	FRU name of the hard disk drive
DE	device end (channel status)	HDR	header
DFA	FRU name of the disk file adapter card	hex	hexadecimal
DIF	disk function	HLIR	high-level interrupt request
DIV	diagnostic information vector	HPP bus	high-performance parallel bus
DMA	direct memory access	HPTSS	high-performance transmission sub-system
DMUX	FRU name of the double multiplex card	HSB	high-speed buffer (cache)
DSI	data store interface	HSS	high-speed scanner
DRS	data rate select	HW	hardware
DTE	data terminal equipment	Hz	Hertz
DTR	data terminal ready (signal)	IBE	internal box error
EAC	Ethernet adapter card	ID	identifier
EC	engineering change	IEEE	Institute of Electrical and Electronics Engineers
ECB	even control block	IFT	internal function test
EIA	Electronic Industries Association	IML	initial microcode load
EINTP1	extended interrupt 1 (register)	in.	inch
EIRV	error interrupt request vector	INN	intermediate network node
ELA	Ethernet LAN adapter	INTP1	interrupt 1 (register)
ENCA	enable CA (register)	INTP4	interrupt 4 (register)
ENQ	enquiry (BSC)	IO	input/output
EPO	emergency power-OFF	IOC	input/output control
ERC	error reference code	IOIRV	input/output interrupt request vector
ESCC	Enterprise System Connection coupler	IOH	input/output halfword (instruction)
ESCC2	ESCC type 2	IOHI	input/output halfword immediate (instruction)
ESCP	Enterprise system connection processor	IPL	initial program load
ESS	Ethernet subsystem	IR	interrupt request
ETG	Ethernet tail gate	IRR	interrupt request removed

ISO	International Organization of Standardization	MCF	microcode fix
KB	kilobyte (1024 bytes)	MCRA	mode control register A
kbps	kilobits per second	MCT	machine configuration table
kg	kilogram	MDOR	MOSS data operand register
kHz	kilohertz	MES	miscellaneous equipment specification
LA	1) load address (instruction) 2) line adapter	MHz	megahertz
LCBB	line connection box base	min	minute
LCBE	line connection box expansion	MIO	MOSS input/output
LCEB	line connection enclosure base	MIOC	MOSS I/O control bus
LCEE	line connection enclosure expansion	MIP	Maintenance Information Procedures
LCPB	line connection power base	MLA	MOSS LAN adapter
LCPE	line connection power expansion	mm	millimeter
LED	light-emitting diode	MMIO	memory mapped input/output
LIB	line interface coupler board	MMOD	MOSS mode (register)
LIB1	LIC board type 1 for LICs 1-4 (models 150 and 170)	MOSS	maintenance and operator subsystem
LIB2	LIC board type 2 for LICs 5-6 (models 150 and 170)	MOSS-E	MOSS extended
LIB3	LIC board type 3 for LICs 1-4 (model 150)	MPC	FRU name of the MOSS processor card
LIC	line interface coupler card	MSA	machine status area
LICx	FRU name of line interface coupler card type x	MSAU	multistation access unit
LID	line interface display	MSC	FRU name of the MOSS storage card
LLIR	low-level interrupt request	MUX	multiplex function
LPDA	Link Problem Determination Aid	mV	millivolt
LS	local storage	NAK	negative acknowledgment character (BSC)
LAS	line adapter status	NCCF	Network Communications Control Facility
LSAR	local storage address register	NCP	Network Control Program
LSR	local storage register (CSP)	NCTE	network communication terminal equipment
LSS	low-speed scanner	NLDM	Network Logical Data Manager
LSSD	level-sensitive scan design	NMVT	network management vector transport
m	meter	NPDA	Network Problem Determination Application
mA	milliampere	NPSI	network packet switching interface
MAC	MOSS adapter card	oc	overcurrent
MAT	manual assurance test	OLT	online test
MAU	media access unit	ov	overvoltage
MB	megabyte; 1 048 576 bytes	PANEL	FRU name of the control panel
MCAD	MOSS/CA Adapter	PC	personal computer
MCC	FRU name of the MOSS control card	PCC	FRU name of the power control card
MCCU	MOSS/CCU Adapter	PCF	primary control field (storage)
		PKD	portable keyboard display
		PIO	program-initiated operation

PIRV	programmed interrupt request vector	SPDn	signal and power distribution card
PNLC	FRU name of the panel card	SPS	service and power support
POR	power-ON reset	SRC	system reference code
PRC	processor	STAT0	status 0 register
PROM	FRU name of the programmable read-only memory module	STAT1	status 1 register
PS	power supply	STAT4	status 4 register
PCSS	power control subsystem	STO	FRU name of the storage (card)
PSTCE	product support trained CE	STO4	FRU name of the storage card 4 Mbytes
PS1	FRU name of power supply number 1	STO8	FRU name of the storage card 8 Mbytes
PS2	FRU name of power supply number 2	SVC	supervisor call
PTCE	product-trained CE	SWx	FRU name of switch number x
PTT	Post, Telephone and Telegraph (agency)	T	transmit (signal)
PUC	FRU name of the CCU card	TA	tag address
PV	parity valid (signal)	TCM	1) thermally-controlled module 2) trellis coded modulation
RAC	repair action code	TD	1) tag data 2) transmitted data (signal)
RCV	receive	TERMD	FRU name of the DMA terminator card
RD	receive data (signal)	TERMC	FRU name of the IOC terminator/channel card
RETAIN	Remote Technical Assistance Information Network	TERMI	FRU name of the IOC terminator card
RFS	ready for sending (signal)	TERMR	FRU name of the IOC terminator/redrive card
RI	1) register to immediate operand (instruction) 2) ring indicator (same as CI)	TI	test indicator (signal)
RIM	request initialization mode (SDLC)	TIC	token-ring interface coupler
RNIO	OS/VS VTAM IO trace	TIC1	FRU name of the TIC card type 1 (4 Mbits only)
ROS	read-only storage	TIC2	FRU name of the TIC card type 2 (4 and 16 Mbits)
RPO	remote power-OFF	TIC3	FRU name of the TIC card type 3 (4 and 16 Mbits)
RSF	remote support facility	TPS	two-processor switch
RTS	request to send (signal)	TRA	token-ring adapter
R/W	read/write	TRM	FRU name of the token-ring multiplexer card that controls up to two TICs
SAR	storage address register	TRP	token-ring processor
SAT	specific assurance test	TRSS	token-ring subsystem
SCTL	FRU name of the storage control card	TSS	transmission subsystem
SDLC	Synchronous Data Link Control	T1	US service for very high speed transmissions at 1.5 million bps
SIM	set initialization mode (SDLC)	UA	unnumbered acknowledgment (SDLC)
SIT	scanner interface trace	UC	universal controller
SMUXA	FRU name of the single multiplex card for LIC board type 2	UEPO	unit emergency power-Off
SMUXB	FRU name of the single multiplex card for LIC board type 2	URSF	universal remote support facility
SNA	Systems Network Architecture		
SNRM	set normal response mode (SDLC)		

V	volt	V.28	CCITT V.28 recommendation
VB	valid byte (signal)	V.35	CCITT V.35 recommendation
VAC	volts, alternating current	WLOB	wire lobe (cable connecting token-ring adapters to token-ring access units)
VDC	volts, direct current	XI	X.25 SNA interconnection
VH	valid halfword (signal)	XID	exchange identification
VTAM	Virtual Telecommunications Access Method	X.21	CCITT X.21 recommendation
V.24	CCITT V.24 recommendation	X.25	CCITT X.25 recommendation
V.25	CCITT V.25 recommendation		

Glossary

This glossary defines all new terms used in this manual. It also includes terms and definitions from the *IBM Dictionary of Computing*, GC20-1699.

adapter-initiated operation (AIO). A transfer of up to 256 bytes between an adapter (CA or LA) and the CCU storage. The transfer is initiated by an IOH/IOHI instruction, and is performed in cycle stealing via the IOC bus.

alarm. A message sent to the MOSS console. In case of an error a reference code identifies the nature of the error.

alert. A message sent to the host console. In case of an error a reference code identifies the nature of the error.

autoBER. A program to automatically analyse a BER file.

automaint. A function that uses autoBER to isolate failing FRUs.

buffer chaining channel adapter (BCCA). A channel adapter that handles buffer chaining in write channel program and both buffer chaining and PIU chaining in read channel program. BCCA works only under NCP.

box event record (BER). Information about an event detected by the controller. It is recorded on the disk/diskette and can be displayed on the operator console for event analysis.

block multiplexer channel. A multiplexer channel that interleaves blocks of data. See also *byte multiplexer channel*. Contrast with *selector channel*.

byte multiplexer channel. A multiplexer channel that interleaves bytes of data. See also *block multiplexer channel*. Contrast with *selector channel*.

cache. A high-speed buffer storage that contains frequently accessed instructions and data; it is used to reduce access time.

central control unit (CCU). In the 3745, the controller hardware unit that contains the circuits and data flow paths needed to execute instructions and to control its storage and the attached adapters.

channel adapter (CA). A communication controller hardware unit used to attach the controller to a host processor.

clear channel. Mode of data transmission where the data passes through the DCE and network, and arrives

at the receiving communication controller unchanged from the data transmitted. The DCE or network can modify the data during transmission because of certain network restrictions, but must ensure the received data stream is the same as the transmitted data stream.

communication controller. A communication control unit that is controlled by one or more programs stored and executed in the unit. Examples are the IBM 3705, IBM 3725/3726, IBM 3720, and IBM 3745.

communication scanner processor (CSP). The processor of a scanner.

communication subsystem. The part of the controller that controls the data transfers over the transmission interface.

configuration data file (CDF). A MOSS file that contains a description of all the hardware features (presence, type, address, and characteristics).

control panel. A panel that contains switches and indicators for the use of the customer's operator and service personnel.

control program. A computer program designed to schedule and to supervise the execution of programs of the controller.

control subsystem (CSS). The part of the controller that stores and executes the control program, and monitors the data transfers over the channel and transmission interfaces.

data circuit-terminating equipment (DCE). The equipment installed at the user's premises that provides all the functions required to establish, maintain, and terminate a connection, and the signal conversion and coding between the data terminal equipment (DTE) and the line. For example, a modem is a DCE (see *modem*.)

Note: The DCE may be separate equipment or an integral part of other equipment.

data terminal equipment (DTE). That part of a data station that serves as a data source, data link, or both, and provides for the data communication control function according to protocols.

direct attachment. The attachment of a DTE to another DTE without a DCE.

high-performance transmission subsystem (HPTSS). The part of the controller that controls the

data transfers over the high-speed transmission interface (speed up to 2 million bps).

high-speed scanner. Line adapter for lines up to 2 million bps, composed of a communication scanner processor (CSP) and a front-end high-speed scanner (FESH).

initial microcode load (IML). The process of loading the microcode into a scanner or into MOSS.

initial program load (IPL). The initialization procedure that causes 3745 control program to commence operation.

input/output control (IOC). The circuit that controls the input/output from/to the channel adapters and scanners via the IOC bus.

internal clock function. A LIC function that provides a transmit clock for sending data, and retrieves a receive clock from received data, when the modem does not provide those timing signals. When the terminal is connected in direct-attach mode (without modem) the ICF also provides the transmit and receive clocks to the terminal, via the LIC card.

line adapter (LA). The part of the TSS, HPTSS, or TRSS that scans and controls the transmission lines. Also called *scanner*.

For the TSS the line adapters are low-speed scanners (LSSs).

For the HPTSS the line adapters are high-speed scanners (HSSs).

For the TRSS the line adapters are token-ring adapters (TRAs).

line interface coupler (LIC). A circuit that attaches up to four transmission cables to the controller.

low-speed scanner. Line adapter for lines up to 256 kbps, composed of a CSC card.

maintenance and operator subsystem (MOSS). The part of the controller that provides operating and servicing facilities to the customer's operator and the IBM service representative.

NetView. An IBM licensed program used to monitor a network, manage it, and diagnose its problems.

Network Control Program (NCP). An IBM licensed program that provides communication controller support

for single-domain, multiple-domain, and interconnected network capability.

operator console. The IBM Operator Console that is used to operate and service the communication controller (CC) through the MOSS. Optionally an alternate console may be installed up to 120 m from the CC, or a remote console may be connected to the (CC) through the switched network.

scanner. A device that scans and controls the transmission lines. Also called *line adapter*.

selector channel. An I/O channel designed to operate with only one I/O device at a time. Once the I/O device is selected, a complete record is transferred one byte at a time. Contrast with *block multiplexer channel*, *multiplexer channel*.

Systems Network Architecture (SNA). The description of the logical structure, formats, protocols, and operational sequences for transmitting information through a user application network. The structure of SNA allows the users to be independent of specific telecommunication facilities.

token-ring subsystem (TRSS). The part of the controller that controls the data transfers over an IBM Token-Ring Network.

The TRSS consists of one or several token-ring adapter (TRA).

token-ring adapter (TRA). Line adapter for an IBM Token-Ring Network, composed of one token-ring multiplexer card (TRM), and two token-ring interface couplers (TICs).

transmission subsystem (TSS). The part of the controller that controls the data transfers over low- and medium-speed, switched and non switched transmission interfaces.

The TSS consists of up to six low-speed scanners (LSSs).

two-processor switch (TPS). A feature of the channel adapter that connects a second channel to the same channel adapter.

V.24,25,35. EIA/CCITT recommendations on transmission interfaces

X.20 bis, 21, 21 bis, 21 native, 25. CCITT recommendations on transmission interfaces

Bibliography

Customer Documentation for the 3745 (Models 130, 150, 160, 170, and 17A) and 3746 (Model 900)

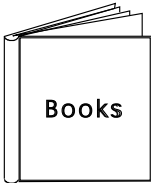

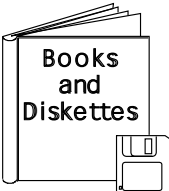



Table X-1 (Page 1 of 4). Customer Documentation for the 3745 Models 130 to 17A and 3746 Model 900		
This customer documentation has the following formats:		
		
Finding Information		
3745 Models A and 3746 Books		
Starting with engineering change (EC) F12380, all of the books in the 3745 Models A and 3746 library are available on the CD-ROM that contains the Licensed Internal Code (LIC) for this EC.		
	<p>SA33-0142</p> <p>IBM 3745 Communication Controller Models 130, 150, 160, 170, and 17A IBM 3746 Expansion Unit Model 900</p> <p>Customer Master Index¹</p> <p>Provides references for finding information in the customer documentation library.</p>	
Evaluating and Configuring		
	<p>GA33-0138</p> <p>IBM 3745 Communication Controller Models 130, 150, and 170</p> <p>Introduction</p> <p>Gives an introduction about the IBM Models 130 to 170 capabilities, including Model 160.</p> <p>For Model 17A refer to the <i>Overview</i>, GA33-0180.</p>	
	<p>GA33-0180</p> <p>IBM 3745 Communication Controller Models A² IBM 3746 Nways Multiprotocol Controller Models 900 and 950</p> <p>Overview</p> <p>Gives an overview of connectivity capabilities within SNA, APPN, and IP networking.</p>	

Table X-1 (Page 2 of 4). Customer Documentation for the 3745 Models 130 to 17A and 3746 Model 900

	GA33-0457	<p>IBM 3745 Communication Controller Models A² IBM 3746 Expansion Unit Model 900 Models 900 and 950</p>
<p>Planning Guide</p>		
<p>Planning for:</p>		
<ul style="list-style-type: none"> • Field upgrades • Service processor and alert management configuration • Network integration (NCP, APPN, and IP control) • Physical installation. 		
<p>Preparing Your Site</p>		
	GC22-7064	<p>IBM System/360, System/370, 4300 Processor Input/Output Equipment Installation Manual-Physical Planning (Including Technical News Letter GN22-5490)</p>
<p>Provides information on physical installation for the 3745 Models 130 to 610. For 3745 Models A and 3746 Model 900, refer to the <i>Planning Guide</i>, GA33-0457.</p>		
	GA33-0140	<p>IBM 3745 Communication Controller Models 130, 150, 160, and 170</p>
<p>Preparing for Connection</p>		
<p>Helps for preparing the 3745 Models 130 to 170 cable installation. For 3745 Model 17A refer to the <i>Connection and Integration Guide</i>, SA33-0129.</p>		
<p>Preparing for Operation</p>		
	GA33-0400	<p>IBM 3745 Communication Controller All Models³ IBM 3746 Nways Multiprotocol Controller Models 900 and 950</p>
<p>Safety Information¹</p>		
<p>Provides general safety guidelines.</p>		
	SA33-0129	<p>IBM 3745 Communication Controller All Models³ IBM 3746 Nways Multiprotocol Controller Model 900</p>
<p>Connection and Integration Guide¹</p>		
<p>Contains information for connecting hardware and integrating network of the 3745 and 3746-900 after installation.</p>		
	SA33-0416	<p>Line Interface Coupler Type 5 and Type 6 Portable Keypad Display</p>
<p>Migration and Integration Guide</p>		
<p>Contains information for moving and testing LIC types 5 and 6.</p>		
	SA33-0158	<p>IBM 3745 Communication Controller All Models³ IBM 3746 Nways Multiprotocol Controller Model 900</p>
<p>Console Setup Guide¹</p>		
<p>Provides information for:</p>		
<ul style="list-style-type: none"> • Installing local, alternate, or remote consoles for 3745 Models 130 to 610 • Configuring user workstations to remotely control the service processor for 3745 Models A and 3746 Model 900, using: <ul style="list-style-type: none"> – DCAF program – Telnet Client program. 		
<p>Customizing Your Control Program</p>		

Table X-1 (Page 3 of 4). Customer Documentation for the 3745 Models 130 to 17A and 3746 Model 900

	SA33-0178	Guide to Timed IPL and Rename Load Module
<p>Provides VTAM procedures for:</p> <ul style="list-style-type: none"> • Scheduling an automatic reload of the 3745 • Getting 3745 load module changes transparent to the operations staff. 		
Operating and Testing		
	SA33-0098	<p>IBM 3745 Communication Controller All Models⁴ Basic Operations Guide¹</p>
<p>Provides instructions for daily routine operations on the 3745 Models 130 to 610.</p>		
	SA33-0177	<p>IBM 3745 Communication Controller Models A² IBM 3746 Nways Multiprotocol Controller Model 900 Basic Operations Guide¹</p>
<p>Provides instructions for daily routine operations on the 3745 Models 17A to 61A and 3746 Model 900 operating as an SNA node (using NCP), APPN/HPR Network Node, and IP Router.</p>		
	SA33-0097	<p>IBM 3745 Communication Controller All Models³ Advanced Operations Guide¹</p>
<p>Provides instruction for advanced operations and testing, using the 3745 MOSS console.</p>		
	On-line Information	Controller Configuration and Management Application
<p>Provides a graphical user interface for configuring and managing a 3746 APPN/HPR Network Node and IP Router, and its resources. Is also available as a stand-alone application, using an OS/2 workstation. Defines and explains all the 3746 Network Node and IP Router configuration parameters through its on-line help.</p>		
	SH11-3081	<p>IBM 3746 Nways Multiprotocol Controller Models 900 and 950 Controller Configuration and Management: User's Guide⁵</p>
<p>Explains how to use CCM and gives examples of the configuration process.</p>		
Managing Problems		
	SA33-0096	<p>IBM 3745 Communication Controller All Models³ Problem Determination Guide¹</p>
<p>A guide to performing problem determination on the 3745 Models 130 to 61A.</p>		
	On-line Information	Problem Analysis Guide
<p>An on-line guide to analyze alarms, events, and control panel codes on:</p> <ul style="list-style-type: none"> • IBM 3745 Communication Controller Models A² • IBM 3746 Nways Multiprotocol Controller Models 900 and 950. 		

Table X-1 (Page 4 of 4). Customer Documentation for the 3745 Models 130 to 17A and 3746 Model 900

	SA33-0175	IBM 3745 Communication Controller Models A² IBM 3746 Expansion Unit Model 900 IBM 3746 Nways Multiprotocol Controller Model 950 Alert Reference Guide
Provides information about events or errors reported by alerts for: <ul style="list-style-type: none">• IBM 3745 Communication Controller Models A²• IBM 3746 Nways Multiprotocol Controller Models 900 and 950.		
<p>¹ Documentation shipped with the 3745. ² 3745 Models 17A to 61A. ³ 3745 Models 130 to 61A. ⁴ Except 3745 Models A. ⁵ Documentation shipped with the 3746-900.</p>		

Service Documentation for the 3745 (Models 130, 150, 160, 170, and 17A) and 3746 (Model 900)

Table X-2 (Page 1 of 4). Service Documentation for the 3745 Models 1x0 and 17A, and 3746 Model 900

This service documentation has the following formats:

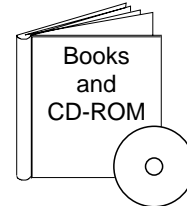

3745 Models A and 3746 Books

Starting with engineering change (EC) F12380, all of the books in the 3745 Models A and 3746 library are available on the CD-ROM that contains the Licensed Internal Code (LIC) for this EC.



SY33-2079

IBM 3745 Communication Controller Models 130, 150, 160, 170, and 17A

Service Master Index¹

Provides references for finding information in the IBM 3745 Models 1X0 and 17A shipping group documentation.



SY33-2067

IBM 3745 Communication Controller Models 130, 150, 160, 170, and 17A

Installation Guide¹

Provides instructions for installing or relocating the IBM 3745 Models 1X0 and 17A.



SY33-2114

IBM 3746 Nways Multiprotocol Controller Model 900

Installation Guide²

Provides instructions for installing or relocating the IBM 3746 Model 900.



SY33-2116

IBM 3746 Nways Multiprotocol Controller Model 900

Service Guide²

Provides procedures for isolating and fixing the IBM 3746 Model 900 problems.



SY33-2069

IBM 3745 Communication Controller Models 130, 150, 160, and 170

Service Functions¹

Describes MOSS functions using the IBM 3745 Models 1X0 and 17A consoles.



SY33-2070

IBM 3745 Communication Controller Models 130 to 17A

Maintenance Information Procedures¹

Provides procedures for isolating and fixing the IBM 3745 Models 1X0 and 17A problems.

Table X-2 (Page 2 of 4). Service Documentation for the 3745 Models 1x0 and 17A, and 3746 Model 900

	SY33-2115	<p>IBM 3745 Communication Controller Models A³ IBM 3746 Expansion Unit Model 900 IBM 3746 Nways Multiprotocol Controller Model 950</p> <p>Service Processor Installation and Maintenance⁴ (Based on the 7585, 3172, 9585, or 9577)</p>	
<p>Provides information on installing and maintaining the service processor based on PS/2 Types 7585, 3172, 9585, or 9577. Can be for systems with microcode that has up to and including EC D46130 (any level) installed.</p>		SY33-2120	<p>IBM 3745 Communication Controller Models A³ IBM 3746 Expansion Unit Model 900 IBM 3746 Nways Multiprotocol Controller Model 950</p> <p>Service Processor Installation and Maintenance⁴ (Based on the 7585, 3172, or 9585)</p>
<p>Provides information on installing and maintaining the service processor based on PS/2 Types 7585, 3172, or 9585. Can be for systems with microcode EC F12380 or higher installed.</p>		SY33-2118	<p>IBM 3746 Nways Multiprotocol Controller Models 900 and 950</p> <p>Multiaccess Enclosure Installation and Maintenance⁴</p>
<p>Provides information on installing and maintaining the Multiaccess Enclosure (MAE).</p>		SY33-2112	<p>IBM 3746 Nways Multiprotocol Controller Models 900 and 950</p> <p>Network Node Processor Installation and Maintenance⁴ (Based on the 7585 or 3172)</p>
<p>Provides information on installing and maintaining the network node processor based on the PS/2 Type 7585 or 3172.</p>		SY33-2066	<p>IBM 3745 Communication Controller Models 130, 150, 160, and 170</p> <p>Hardware Maintenance Reference¹</p>
<p>Provides in-depth hardware reference information on the IBM 3745 Models 1X0 and 17A. Also valid for the 3745 Model 17A.</p>		SY33-2075	<p>IBM 3745 Communication Controller All Models⁶</p> <p>External Cable References¹</p>
<p>Provides references to console and line cables used for connecting the IBM 3745 Models 130 to 61A.</p>		SY33-2117	<p>IBM 3746 Nways Multiprotocol Controller Models 900 and 950</p> <p>External Cable Reference⁷</p>
<p>Provides references to console and line cables used for connecting the IBM 3746 Models 900 and 950.</p>			

Table X-2 (Page 3 of 4). Service Documentation for the 3745 Models 1x0 and 17A, and 3746 Model 900





	S135-2015	IBM 3746 Nways Multiprotocol Controller Models 900 and 950 Parts Catalog⁷ Provides reference information for ordering parts for the IBM 3746 Models 900 and 950.
	S135-2012	3745 Communication Controller Models 130 to 17A Parts Catalog¹ Provides reference information for ordering IBM 3745 Models 1X0 and 17A parts.
	S135-2014	IBM Controller Expansion Parts Catalog Provides reference information for ordering parts for the controller expansion attached to the IBM 3746 Model 900 and 950.

Table X-2 (Page 4 of 4). Service Documentation for the 3745 Models 1x0 and 17A, and 3746 Model 900

CD-ROM Bibliography		
	ZK2T-8214	<p>IBM Networking Softcopy Collection Kit</p> <p>Allows service manuals consulting via CD-ROM viewer. EMEA version.</p>
	ZK2T-8187	<p>IBM Networking Softcopy Collection Kit</p> <p>Allows service manuals consulting via CD-ROM viewer. US version.</p>
<p>¹ Documentation shipped with the 3745. ² Documentation shipped with the 3746-900. ³ 3745 Models 17A to 61A. ⁴ Documentation shipped with the processor. ⁵ Product integrated information. ⁶ 3745 Models 130 to 61A. ⁷ Documentation shipped with the 3746 Models 900 and 950.</p>		

Index

Numerics

- 100 ms interval timer (CCU) 2-19
- 2701 1-22
- 2702 1-22
- 2703 1-22
- 3002 channel (US) characteristics 4-66
- 3161 console 3727 console key conversion 9-8
- 3727 console 3161 console key conversion 9-8
 - maintenance 9-8
 - setup 9-8
- 3745
 - capacity 1-5
 - data flow 1-3, 10-2
 - identification 1-5
 - model 130 1-5
 - model 150 1-5
 - model 170 1-5
 - model 17A 1-6
 - power ON/OFF 1-19
- 3745 down 11-24
- 3745 mode (clocking) 4-51
- 3746-900
 - console summary 1-18
 - operator consoles 9-8
 - power connection and control 10-34
- 3746-900 adapter addressing (CBC, PRC) 3-36
- 3746-900 BER formats 11-159
- 3746-900/3745 bus attachment 3-30

A

- A register (CCU) 2-20
- aa LIC5 FAILED 4-79
- aa LIC6 FAILED 4-90
- AC
 - detection 10-26
 - frequency 10-5
 - monitoring 10-26
- AC voltages input
 - adjustment 10-5
 - limits 10-5
- access methods 1-20
- access protocol (TRSS ring) 6-7
- actions taken during AIOs and PIOs (CCU) 2-49
- adapter check register (TIC) 6-24
- adapter interface check stop mode (CCU) 2-48
- adapter plugging rules 3-48
- adapter return codes 11-59
- adapters interconnection errors (CCU) 2-47
- adapters/CCU interconnection 3-6

- address
 - DCE, LIC type 6 4-86
- address exception
 - CCU 2-18
 - instruction fetch error (CCU) 2-47
 - program execution error (CCU) 2-47
- address register
 - LIC types 1 to 4 4-47
 - LIC types 5/6 (DTE function) 4-55
- address/command tag 3-7
- addressing
 - 3746-900 adapter (CBC, PRC) 3-36
 - CA 3-32
 - ESS line 3-45
 - HPTSS line 3-45
 - LIC board 3-38
 - LIC1 LIC3 LIC4A and LIC4B 3-40
 - LIC5 and LIC6 3-42
 - line 3-39
 - line adapter (LSS, ELA, and HSS) 3-34
 - logical adapter 3-31
 - logical, on LIC types 1 to 4 4-46
 - MOSS screen display CA 3-33
 - MOSS screen display LA 3-35
 - physical wiring 3-31
 - the ELA CSP 12-28
 - the lines in ELA 12-6
 - the lines in HSS 5-6
 - token-ring 3-47
 - token-ring adapter 3-46
 - token-ring line 3-47
 - TSS line LICs 1-4 3-41
 - TSS line LICs 5-6 3-44
- aid
 - HSS microcode service aid 5-37
 - on HSS problem determination 5-37
 - on TRA problem determination 6-27
- aids
 - microcode service 12-45
 - on ELA problem determination 12-45
- AIO
 - CA
 - read indirect operation 3-25
 - write indirect operation 3-26
 - direct/indirect LA/TRA read 3-27
 - direct/indirect LA/TRA write 3-28
 - operation 3-19
 - operation sequence
 - CSCW transfer 3-21
 - data transfer in read 3-24
 - data transfer in write 3-23
 - for CA (storage address transfer) 3-22
 - for LA (storage address transfer) 3-22

AIO (*continued*)
 operation sequence (*continued*)
 initialization 3-20
 TRA read direct operation 3-28
 air flow detector 10-27, 10-28
 monitoring 10-27
 principle 10-28
 alarm
 tone detection, LIC type 6 4-87
 alarm/alert 11-16
 alter
 CSP control storage 4-15
 CSP external registers 4-15
 CSP local storage 4-15
 CSP ROS (read-only storage) 4-15
 alternate console 9-6
 analog
 line analysis test 4-99
 test from PKD 4-77
 arbitration mechanism (TRM) 6-18
 ARC 11-59
 asynchronous operation command
 CHHITMIO input 4-29
 FESA X'15' register 4-29
 autodiagnosics 7-22
 automatic BER analysis 11-18
 automatic dump of scanner (ELA) 12-28
 automatic FRU correlation 11-20
 automatic restart function 10-24
 autoselection (AS) 3-49
 chain 7-12
 error 7-13
 mechanism 7-12

B

background information
 on PKD 4-75
 backup speed
 LIC type 5 (DCE function) 4-70
 bad response
 on PKD 4-76
 basic board DC voltages and tolerances 10-11
 basic configuration 1-6
 BCCA 7-4
 BER
 alarm/alert 11-12
 composite 11-15
 detail screen 11-13
 display 11-8, 11-13
 error status 11-10
 file erasure 11-8
 format 11-6
 handling tools 11-11
 Id 11-9
 specific mechanism 11-12

BER (*continued*)
 storage on disk 11-7
 structure 11-10
 type 11-9
 BER analysis 11-18
 automatic analysis 11-18
 automatic FRU correlation 11-20
 CE field updating 11-19
 correlation range 11-20
 manual analysis 11-19
 manual FRU correlation 11-20
 BER format on disk 11-112
 BER reference code 11-19, 11-21
 BER type 01 11-33, 11-39
 summary 11-33
 BER type 01 - ID 00
 detailed BER display 11-39
 error code description 11-40
 field description 11-39
 field details 11-44
 MOSS check codes 11-40
 BER type 01 formats 11-112
 BER type 01 ID 01
 detailed BER display 11-50
 field description 11-50
 field details 11-51
 BER type 01 ID 02
 detailed BER display 11-53
 field description 11-53
 field details 11-54
 BER type 01 ID 03
 adapter return codes 11-59
 detailed BER display 11-56
 field description 11-56
 field details 11-57
 BER type 01 ID 04
 detailed BER display 11-60
 field description 11-60
 field details 11-60
 BER type 01 ID 05
 detailed BER display 11-63
 field description 11-65
 BER type 01 ID 06
 detailed BER display 11-66
 error 05 11-72
 error 08 11-73
 error 09 11-74
 error 13 11-76
 error 14 11-76
 error 18 11-76
 error 28 11-77
 field details 11-68
 BER type 01 ID 07
 field details 11-78
 BER type 01 ID 08 11-80

- BER type 01 ID 0A
- BER type 01 ID 15 and 16 11-82
- BER type 01 ID 17 11-84
- BER type 01 ID 19 11-85
- BER type 01 ID 20 11-86
 - field details 11-87
- BER type 01 ID 21 11-90
 - field details 11-90
- BER type 01 ID 43 11-97
 - field details 11-97
- BER type 01 ID 44 11-101
- BER type 01 ID 50 11-102
- BER type 01 ID 80 11-102
- BER type 01 IDs 10 to 14 11-81
- BER type 01 IDs 16 and 1A to 1D 11-83
- BER type 01 IDs 24 to 29 and 37 11-94
- BER type 01 IDs 30 to 32 11-94
 - field description 11-95
- BER type 01 IDs 38 and 39 11-95
 - field details 11-96
- BER type 01 IDs 91, B3, C1, C2 11-102
- BER type 03
 - detailed BER display 11-123
 - formats 11-124
 - summary 11-123
- BER type 04
 - detailed BER display 11-125
 - field details 11-128
 - formats 11-132
 - RESP field 11-131
 - RESP/REQ codes 11-129
 - summary 11-125
- BER type 08
 - detailed BER display 11-137
 - field description 11-141
 - formats 11-143
 - summary 11-133
- BER type 09
 - detailed BER display 11-149
 - field description 11-156
 - formats 11-159
 - summary 11-145
- BER type 10
 - detailed BER display 11-169
 - field description 11-173
 - formats 11-176
 - summary 11-164
- BER type 11
 - detailed BER display 11-184
 - field description 11-187
 - formats 11-189
 - summary 11-179
- BER type 12
 - field description 11-192
 - formats 11-193
 - summary 11-191
- BER type 13
 - detailed BER display 11-195
 - field description 11-196
 - formats 11-197
 - summary 11-194
- BER type 14
 - detailed BER display 11-199
 - field description 11-199
 - format 11-200
 - summary 11-198
- BER type 15
 - detailed BER display 11-203
 - field description 11-206
 - formats 11-208
 - summary 11-201
- BER type description 11-9
- BER which are not machine errors 11-11
- bibliography xiv
- BPC card plugging rules 3-48
- BPC1 3-29
- BPC2 3-29
- branch trace 8-11
- branch trace buffer 8-11
- bridges (token-ring) 6-8
- BTAM 1-20
- BTAM-ES 1-20
- buffer chaining channel adapter 7-4
- burst count checker (DMA) 5-25, 12-38
- bus
 - 3746-900/3745 attachment 3-30
 - DMA 3-10
 - interconnection control (TIC) 6-14
 - IOC 3-4
 - layout 3-5
 - main 3-4
 - propagation cards 3-29
 - signal lines summary of the TIC bus 6-18
 - summary of the IOC bus interface signal lines 6-17
 - to TIC interconnection 6-17
- bus propagation cards 3-29
- bus terminator connector pin assignment 3-60
- busy TC on
 - on PKD 4-76
- buzzer control
 - on PKD 4-78
- bypass mechanism for LAs or CAs 3-48

C

- CA
 - level 3 interrupt 7-16
- CA addressing 3-32
- CA (channel adapter)
 - autoselection (AS) 7-12
 - initialization 7-24
 - instructions 7-9

CA (channel adapter) *(continued)*
 interface display 7-24
 interrupt requests 7-16
 level 1 interrupt 7-16
 operating environment 7-8
 services 7-24
 states 7-9
 testing and checking hardware 7-22
 wrap plugs 7-23
 CA addresses decoding 2-33
 CA BER
 See ?
 CA BER formats 11-176
 CA bypass mechanism 3-48
 CA IPL detect 3-8
 CA plugging rules 3-48
 CA/MOSS connection 7-15
 cable
 diagrams (HSS) 5-41
 length limitations (HSS) 5-42
 LIC types 1 to 4 4-100
 TSS 4-100
 V.35
 example of two cables connected (HSS) 5-41
 X.21
 example of two cables connected (HSS) 5-41
 cabling system (TRSS ring) 6-5
 cache storage (CCU) 2-17
 capacity of the 3745 1-5
 card EC level
 LIC type 5 (DCE function) 4-70
 card replacement
 SMUX 4-40
 carrier detector sensitivity
 LIC type 5 (DCE function) 4-69
 CCITT
 LIC type 5 (DCE function) 4-70
 loop 3, LIC type 5 (DCE function) 4-71
 mode, LIC type 5 (DCE function) 4-62, 4-63
 CCMD (ELA) 12-30
 CCU
 cpckaging 2-4
 cycle 2-5
 data flow 2-4
 detected hardware errors 2-44
 detected not hard errors 2-44
 diagnostics 2-43
 environment 2-12
 error detection 2-46
 error handling 2-44
 error handling summary 2-45
 functional description 2-5
 general description 2-4
 hard errors 2-39
 in 3745 data flow 2-2
 registers 2-21
 CCU *(continued)*
 storage interconnection 2-17
 storage line invalidation 2-18
 storage read policy (CCU) 2-18
 storage write policy 2-18
 subsystem POR 2-13
 timers 2-19
 to and from adapters 2-20
 to and from MOSS 2-43
 CCU BER
 See BER type 13
 CCU BER formats 11-197
 CCU bus 3-4, 3-6
 function 3-6
 CCU to MOSS communication 8-14
 CCU/adapters interconnection 3-6
 CCUI logic 2-15
 CE field updating
 See BER analysis
 central control unit (CCU) 2-1
 channel adapter addresses 3-33
 channel adapter bypass mechanism 3-48
 channel adapter plugging rules 3-48
 channel signals used by the CA 7-11
 channel stop 7-21
 channel wrap 7-22
 characteristics
 LIC types 1 to 4 4-9
 LIC types 5/6 4-11
 check register decoding (TIC adapter) 6-24
 check stop mode (CCU) 2-44
 checkers 2-44
 checking the checkers (CCU) 2-44
 CLDP-HSS microcode exchange 5-10
 clear (X.21) 4-33
 clock
 CSP 4-18
 failure (FESH DCE) 5-20
 clocking
 3745 mode 4-51
 direct mode 4-51
 external mode 4-51
 HSS line 5-42
 internal mode 4-50
 CMD FROM DTE 4-79, 4-90
 CMD FROM LINE 4-79, 4-90
 comands
 mailbox 8-15
 command rejection
 on PKD 4-76
 commands
 description for ELA 12-18
 disk/diskette 8-19
 in CE mode, from PKD 4-78
 LIC type 5 configuration 4-70
 LIC type 5 problem determination 4-70

- commands (*continued*)
 - problem determination, LIC type 6 4-86
 - scanner 4-21
 - TSS, LIC type 6 4-87
- communication
 - CCU to MOSS 8-14
 - interfaces of HSS 5-40
 - MOSS to CCU 8-14
- communication scanner processor
 - See also* CSP (communication scanner processor)
 - ELA 12-14
- communication scanner processor (HSS) 5-11
- communication subsystem 1-8
- component location
 - primary power box 10-6
 - PS1 10-9
- composite BER 11-15, 11-30
- conditional branch trace 8-12
- CONFIG FROM HOST 4-79
- CONFIG FROM LINE 4-79
- CONFIG MISMATCH 4-79
- configuration
 - (CA) 7-5
 - basic 1-6
 - BPC1/BPC2 rules 3-29
 - CA with TPS 7-6
 - commands (LIC type 5, DCE function) 4-70
 - DSU/CSU, LIC type 6 4-88
 - from PKD 4-77
 - LIC type 5 (DCE function) 4-58, 4-67, 4-73
 - LIC type 6 4-81, 4-85, 4-89
 - LIC types 1 to 4 4-46
 - minimum 1-6
 - options for LIC type 6 4-82
 - options, LIC type 5 (DCE function) 4-60
- configuration rules BPC1/BPC2 cards 3-29
- connection
 - DMA bus to EAC 12-13
 - DMA bus to FESH 5-11
 - FESH to CSP 5-10
 - IOC bus to CSP (ELA) 12-13
 - IOC bus to CSP (HSS) 5-10
 - LIC type 6 to DDS 4-80
 - LIC type 6, limited distance 4-80
- connection to 3746-900 power 10-34
- console
 - connection 9-8
- console attachment
 - alternate 1-17
 - local 1-17
 - remote 1-17
 - RSF 1-17
- console sharing via IBM 7427 9-7
- consoles tail gate 9-7
- contact sense/operate
 - from PKD 4-78
- contingent allegiance 7-18
- control panel 9-2, 9-3
 - connection 9-5
 - operation 9-5
 - overview 9-2
 - reference card 9-4
- control program
 - See also* NCP
 - generation 1-23
 - loading 1-23
 - loading from disk, automatic 1-23
 - multiple load module 1-23
- control register
 - LIC types 1 to 4 4-47
 - LIC types 5/6 (DTE function) 4-55
- control ROS parity error (CCU) 2-46
- control storage
 - CSP 4-15
- control subsystem 1-7
- controller structure 1-7
- controller-resident programs 1-22
- cpckaging
 - CCU 2-4
 - HSS 5-5
 - TRSS 6-10
- cpparameters
 - for HSS customization 5-22
- cprrtitioning the functions in SCTL 2-15
- CSP
 - addressing (ELA) 12-28
 - interconnection to EAC 12-13
 - layer (ELA) 12-16
 - of the ELA 12-14
- CSP (communication scanner processor)
 - components 4-13
 - control storage 4-15
 - data flow 4-13
 - definition 4-13
 - error management 4-18
 - external registers 4-15
 - external registers usage 4-18
 - FES 4-7
 - FESA (front-end scanner adapter) 4-7
 - FESA interconnection 4-28
 - FESL 4-7
 - general information 4-7
 - hardstop 4-18
 - layer (HSS) 5-14
 - local storage 4-15
 - of the HSS 5-11
 - program levels 4-18
 - programmed reset PIO 4-20
 - reset 4-20
 - ROS (read-only storage) 4-15
 - scanner commands 4-21
 - scanner states 4-19

- CSP card in the ELA
 - function 12-11
- CSP-to-IOC bus connection (ELA) 12-13
- CSP-to-IOC bus connection (HSS) 5-10
- CSS 1-7
- CSU
 - configuration, LIC type 6 4-88
 - information, LIC type 6 4-88
 - LIC type 6 4-86
- CTS state confirmation (FESH) 5-20
- current command (ELA) 12-30
- customer power control 9-7
- customization parameters (HSS) 5-22
- cycle steal
 - grant 3-49
 - pointer allocation (CCU) 2-21
- cycle steal (CS) 7-14
 - chain 7-14
 - grant high 3-7
 - grant low 3-7
 - request high 3-7
 - request low 3-7

D

- D register (CCU) 2-20
- D1/D2 register parity errors (two errors) (CCU) 2-46
- data
 - format with LIC type 6 4-82
- data bus bytes 0 and 1 3-9
- data bus parity checker (DMA) 5-24, 12-38
- data encoding and modulation
 - LIC type 5 (DCE function) 4-61
- data flow
 - 3745 1-3
 - buses in 3745 3-2
 - CA 7-7
 - CA in 3745 7-2
 - CCU 2-4
 - CCU in 3745 2-2
 - ESS 12-8
 - ESS in 3745 12-3
 - HPTSS 5-8
 - HPTSS in 3745 5-3
 - IOC (CCU) 2-20
 - LIC type 5 (DCE function) 4-57
 - LIC type 6 4-80
 - MOSS in 3745 8-2
 - power control 10-16
 - power system in 3745 10-2
 - TIC 6-12
 - TRSS in 3745 6-2
 - TSS in 3745 4-4
- data management
 - ELA 12-34
 - HSS 5-11

- data RAM
 - FESA 4-31
- data reception (HSS) 5-11
- data streaming 7-5
- data tag 3-7
- data transfer methods 7-9
- data transfer state (CA) 7-10
- data transmission (HSS) 5-10
- data value register (CCU) 2-43
- DC voltage test points
 - PS1 10-9
- DC voltages and tolerances
 - CSP, FESH, EAC cards 10-12
 - disk 10-14
 - diskette 10-14
 - PS1 10-10
 - PS2 10-13
- DCE
 - address, LIC type 5 4-69
 - address, LIC type 6 4-86
 - information (on PKD) 4-75
- DCE clock failure (FESH) 5-20
- DCE to telephone line interface
 - LIC type 5 4-63
- DDS (digital data service)
 - LIC type 6 connection 4-80
 - line specifications 4-84
 - loop, LIC type 6 4-87
 - speed for LIC type 6 4-81
- DDS LINE DOWN 4-90
- DDS OOS or DDS OOF 4-90
- debugging
 - aid for LIC types 1 to 4 4-92
 - aid for LIC types 5/6 4-95
- DEFAULT CONFIG 4-90
- default speed
 - LIC type 5 (DCE function) 4-69
- definitions
 - DMUX (double multiplexer card) 4-8
 - FES (front end scanner) 4-23
 - FESA (front-end scanner adapter) 4-27
 - LIC (line interface coupler) 4-9
 - LIC board 4-8
 - LSS (low-speed scanner) 4-7
 - MUX (multiplexer card) 4-8
 - SMUX (single multiplexer card) 4-9
 - TSS (transmission subsystem) 4-6
- description
 - FESA 4-28
- description of the BER type 11-9
- detection and reporting
 - hardware error (ELA) 12-36
 - internal box error (IBE) (ELA) 12-37
 - of error (ELA) 12-36
- diagnostic BER
 - See BER type 03

- diagnostic BER formats 11-124
- diagnostic facilities (ELA) 12-44
- diagnostic section TA0A warning 6-19, 6-27
- diagnostics
 - CCU 2-43
 - facilities (HSS) 5-37
- digital test
 - from PKD 4-77
- direct memory access
 - CCU 2-14
- direct memory access operation (TRA) 6-17
- direct mode (clocking)
 - See 3745 mode (clocking)
- disable
 - LIC types 1 to 4 line 4-44
 - LIC types 5/6 (DTE function) line 4-55
- disabled
 - LIC 4-31
- disabled state (CA) 7-10
- disconnected 4-19
 - disconnected-go 4-19
- disconnected-go 4-19
- disconnected-stop 4-19
- disk drive (HDD) 9-9
- disk/diskette commands 8-19
- disk/diskette drive 9-9
- disk/diskette drive ON/OFF control 10-14
- diskette drive 9-10
 - description 9-10
 - part number 9-10
 - removal and replacement procedure 9-10
- display
 - CSP control storage 4-15
 - CSP external registers 4-15
 - CSP local storage 4-15
 - CSP ROS (read-only storage) 4-15
- DMA
 - 3746-900/3745 attachment 3-30
 - burst count checker 5-25, 12-38
 - bus 3-10
 - bus during read operation 3-13
 - bus during write operation 3-14
 - bus interconnection layout 3-11
 - bus physical interconnection 3-10
 - bus to EAC connection 12-13
 - bus to FESH connection 5-11
 - data bus parity checker 5-24, 12-38
 - DMA bus errors reported by FESH 5-27
 - DMA/SCTL errors 12-40
 - ELA DMA manager layer 12-16
 - errors reporting 5-26, 12-40
 - HSS DMA manager layer 5-14
 - interconnection errors detected by EAC 12-38
 - interconnection errors detected by FESH 5-24
 - logic (CCU) 2-15
 - operation (TRA) 6-17

- DMA (*continued*)
 - size 5-22
 - tag sequence 5-24, 12-38
 - time out 5-25, 12-38
- DMA interconnection errors detected by EAC 12-38
- DMA-to-SCTL bus line function 3-11
- DMUX (double multiplexer card)
 - definition 4-8
 - functional description 4-37
 - functions 4-35
 - reset 4-37
- double multiplexer card
 - See DMUX (double multiplexer card)
- DSR 4-32
 - confirmation (FESH) 5-19
 - integration timer (HSS) 5-22
- DSU
 - configuration, LIC type 6 4-88
 - information, LIC type 6 4-88
 - LIC type 6 4-86
- DTE clocking
 - LIC types 1 to 4 4-9
 - LIC types 5/6 4-11
- DTE function
 - LIC types 5/6 4-54
- dump of scanner (automatic), (ELA) 12-28

E

- EAC
 - card 12-15
 - DMA bus connection 12-13
 - interconnection to CSP 12-13
 - internal checkers 12-42
 - microcode 12-13
 - report of SCTL/switch card detected errors 12-39
 - reset 12-17
- ECA layers 12-15
- ECC and MCTL (CCU) 2-15
- effect of selective reset on CA 7-20
- effect of system reset on CA 7-19
- ELA
 - CCMD 12-30
 - command description 12-18
 - commands NCP 12-7
 - CSP 12-14
 - CSP card 12-11
 - CSP layer 12-16
 - CSP-to-IOC bus connection 12-13
 - data management 12-34
 - diagnostic facilities 12-44
 - DMA manager layer 12-16
 - error status 12-42
 - formats of input/output instruction 12-25
 - get command reject status 12-27
 - get error status 12-27

ELA (continued)

- get line ID 12-27
- get microcode check 12-27
- in system environment 12-5
- interface or port types 12-7
- internal interconnections 12-13
- introduction 12-5
- IOH/IOHI instruction summary 12-26
- LCS 12-30
- line addressing 12-6
- microcode
 - service aid 12-45
- packaging 12-5
- port or interface types 12-7
- problem determination aid 12-45
- PSA 12-25
- PSA layout 12-29
- SCF 12-29
- set line vector table
 - high (ELA) 12-27
 - low (ELA) 12-27
- set special line vector table
 - high (ELA) 12-28
 - low (ELA) 12-28
- SIT trace 12-45
- start line 12-27
- start line initial 12-27

ELA CSP

- coding layer 12-17
- interconnection errors 12-41
- isolation layer 12-17
- serial conversion layer 12-17
- Transmit/Receive Control Layer 12-17

ELA microcode

- description 12-11
- function 12-11
- interrupt levels 12-11
- structure 12-11

ELA-NCP microcode exchange 12-13

ELCS (for LCS X'D2') for ESS 12-32

ELCS (initial status=B'110') for ESS 12-33

ELCS (initial status=B'110') for HSS 5-35

enable

- LIC types 1 to 4 line 4-44
- LIC types 5/6 (DTE function) line 4-55

enable clock mode

- LIC types 1 to 4 4-47

enabled

- LIC leads 4-31

end of chain 3-8

ending status

- normal tagged status 7-18
- tagged DE status 7-18
- untagged asynchronous status 7-19

environment system for ELA 12-5

environment system for HSS 5-5

EP 1-22

error

- adapter interface check stop mode (CCU) 2-48
- adapters interconnection errors (CCU) 2-47
- address exception instruction fetch error (CCU) 2-47
- address exception program execution error (CCU) 2-47
- CCU detected hardware errors 2-44
- CCU detected not hard errors 2-44
- CCU hard errors 2-39
- control ROS parity error (CCU) 2-46
- D1/D2 register parity errors (two errors) (CCU) 2-46
 - detected by TRM (format 1) 6-22
- detection (CCU) 2-46
- detection and reporting
 - ELA 12-36
 - HSS 5-23
 - TRM 6-20
- DMA bus errors reported by FESH 5-27
- DMA interconnection errors detected by FESH 5-24
- DMA/SCTL reporting 5-26, 12-40
- during MOSS AIOs (CCU) 2-48
- during program AIOs (CCU) 2-48
- handling (CCU) 2-44
- handling summary (CCU) 2-45
- hard stop error status (detected by CSP hardware), (HSS) 5-30
- hardware error detection and reporting (HSS) 5-23
- hardware errors (CCU) 2-46
- internal box error (IBE) reporting (HSS) 5-24
- level 5 I/O error (CCU) 2-47
- local storage parity error (CCU) 2-46
- MIOC parity error (CCU) 2-46
- MOSS address exception error 2-49
- MOSS data operand register (MDOR) parity error (CCU) 2-46
- MOSS interconnection type errors 2-49
- MOSS OP error 2-49
- POP parity error (CCU) 2-46
- program errors (CCU) 2-47
- program/hardware (HSS) 5-23
- SAR parity error (CCU) 2-46
- SCTL card detected errors reported by FESH 5-26
- sequence (HSS) 5-22
- status (ELA) 12-42
- status (HSS) 5-28
- status register (level 2) (TRM) 6-22
- status register (MOSS) (TRA) 6-24
- storage protect instruction fetch error (CCU) 2-47
- storage protect program execution error (CCU) 2-47
 - with MOSS user (MIOH) (CCU) 2-48
 - with program user (IOH, IOHI) (CCU) 2-48
- Z register parity error (CCU) 2-46

- error alert
 - from CP 7-21
 - from MOSS 7-21
- error count 11-5
- error management
 - CSP 4-18
- error status 11-10
- ESC mode 7-8
- ESS 1-13
 - CSP card 12-11
 - data flow 12-8
 - description 12-5
 - ELCS (for LCS X'D2') 12-32
 - ELCS (initial status=B'110') 12-33
 - hardware error status (initial status=B'111') 12-34
 - IBE (initial status=B'110') 12-32
- ESS BER formats 11-143
- ESS CSP
 - address PROM 12-16
 - bus interconnection layer 12-16
- ESS line addressing 3-45
- Ethernet coupler (EAC) card 12-15
- Ethernet subsystem 1-13
- Ethernet subsystem (ESS) 12-1
 - introduction 12-3
- Ethernet-type LAN network 12-5
- exchange time out 8-13
- extended LCS (ELCS) for ESS 12-32, 12-33
- extended LCS (ELCS) for HSS 5-35
- external mode (clocking) 4-51
- external registers
 - CCU 2-21
 - CSP 4-15
 - FESA X'13' 4-29
 - FESA X'15' 4-29
 - line interface address 4-29
- external wrap facility (HSS) 5-38

F

- fan stacked faults 10-28
 - faults logging 10-28
- FDD ON/OFF command 10-14
- features
 - CA 7-5
- FES (front end scanner)
 - data flow 4-23
 - function 4-7
 - power ON reset 4-25
 - programmed reset 4-26
 - RAM A 4-24
 - RAM B 4-24
 - RAM C 4-24
 - storages 4-24
 - storages display 4-24
- FESA (front-end scanner adapter) 4-7
 - CSP interconnection 4-28
 - data flow 4-27
 - data RAM 4-31
 - definition 4-27
 - description 4-28
 - external register X'13' 4-29
 - external register X'15' 4-29
 - inbound and outbound control RAM 4-29
 - inbound/outbound RAM addressing 4-29
 - inbound/outbound RAM layout 4-29
 - local store 6 4-29
 - RAM organization 4-28
 - serial link interconnection 4-28
- FESH
 - card 5-12
 - CTS state confirmation 5-20
 - DCE clock failure 5-20
 - DCE interface 5-40
 - DMA bus connection 5-11
 - DMA bus errors reported by FESH 5-27
 - DSR confirmation 5-19
 - end of receive 5-18
 - flush command 5-18
 - flush end of frame command 5-18
 - hardware functions 5-15, 5-17
 - interconnection to CSP 5-10
 - internal checkers 5-28
 - microcode 5-10
 - modem interface management 5-19
 - modem retrain 5-21
 - modem-in management 5-19
 - modem-out management 5-20
 - receive
 - command 5-17
 - continue command 5-18
 - flow 5-18
 - operation for I-frame 5-18
 - reset 5-15
 - SCTL card detected errors reported by FESH 5-26
 - stop receive command 5-18
- FESL 4-7
 - reset 4-25
- fields analysis 11-18
- final status field (FSF)
 - bit definition 5-33
 - bit definition for ESS 12-31
- flush command (FESH) 5-18
- flush end of frame command (FESH) 5-18
- format 1 (error detected by TRM) 6-22
- format 2 (interrupt request by the TIC) 6-22
- format fol1 11-200
- format of a BER 11-6
- formats foCxx 11-176
- formats foDxx 11-124

- formats foExx 11-143
- formats foMxx 11-112
- formats foNxx 11-193
- formats foPxx 11-132
- formats foRxx 11-208
- formats foSxx 11-159
- formats foTxx 11-189
- formats foUxx 11-197
- formats of input/output instruction (ELA) 12-25
- frame
 - Ethernet version 2 12-9
 - IEEE 802.3 12-10
 - in serial link 4-34
 - slots 4-34
- frame format (token-ring) 6-7
- frequency (AC) 10-5
- front-end scanner
 - See FES (front end scanner)
- front-end scanner adapter (FESA)
 - See FESA (front-end scanner adapter)
- front-end scanner high-speed (FESH) card 5-12
- FRU correlation
 - See BER analysis
- FRU list 11-10
- FSF 5-33
- FSF for ESS 12-31
- function partitioning in SCTL card 2-15
- functional description
 - CCU 2-5

G

- general description
 - 3746-900 connectivity switch 1-16
 - bus 3-4
 - CCU 2-4
 - channel adapter (CA) 7-4
 - control panel 9-2
 - diskette drive 9-10
 - hard disk drive 9-9
 - MOSS 8-4
 - operator consoles 9-6
- general information 1-1
- generation of line ID (TRA) 6-23
- get command reject status (ELA) 12-27
- get error status (ELA) 12-27
- get line ID
 - ELA 12-27
- get microcode check (ELA) 12-27

H

- halt 3-8
- hard disk drive 9-9
 - description 9-9
 - part number 9-9

- hard disk drive (*continued*)
 - removal and replacement procedures 9-9
- hard stop error status (detected by CSP hardware), (ELA) 12-44
- hard stop error status (detected by CSP hardware), (HSS) 5-30
- hard stop error status detected by CSP hardware 12-44
- hard stop transmit command (HSS) 5-17
- hardstop
 - CSP 4-18
- hardware error detection and reporting (ELA) 12-36
- hardware error status (for ESS) 12-34
- hardware error status (initial status=B'111') 5-36
- hardware error status (initial status=B'111') for ESS 12-34
- hardware error status (initial status=B'111') for HSS 5-36
- hardware errors
 - CCU detected 2-44, 2-46
 - detection and reporting (HSS) 5-23
- hardware functions (FESH) 5-17
- hardware registers (CCU) 2-42
- HDD 9-9
- HDD ON/OFF command 10-14
- hexadecimal codes 11-29
- hexadecimal codes versus mosscheck code 11-29
- high and low resolution timer (CCU) 2-19
- high performance transmission subsystem (HPTSS)
 - introduction 5-3
- high-performance transmission subsystem 1-12
- host support
 - LIC type 5 (DCE function) 4-70
 - LIC type 6 4-86
- host-resident programs 1-20
- HPTSS 1-12
 - data flow 5-8
- HPTSS line addressing 3-45
- HSS 5-22
 - commands NCP 5-7
 - communication interfaces 5-40
 - cpckaging 5-5
 - CSP 5-11
 - CSP layer 5-14
 - CSP-to-IOC bus connection 5-10
 - customization parameters 5-22
 - data reception 5-11
 - data transmission 5-10
 - diagnostic facilities 5-37
 - DMA manager layer 5-14
 - ELCS (initial status=B'110') 5-35
 - error status 5-28
 - hard stop transmit command 5-17
 - hardware error status (initial status=B'111') 5-36
 - IBE (initial status=B'110') 5-34
 - in system environment 5-5

- HSS (*continued*)
 - interface FESH-DCE 5-40
 - interface types 5-7
 - internal interconnections 5-10
 - introduction 5-5
 - line addressing 5-6
 - line interface check 5-28
 - microcode
 - functions 5-15, 5-17
 - service aid 5-37
 - modem and data management 5-11
 - problem determination aid 5-37
 - receive
 - operation 5-17
 - soft stop transmit command 5-16
 - time out values used 5-22
 - transmit
 - command 5-16
 - initial command 5-15
 - operation 5-15
 - HSS CSP
 - interconnection errors 5-27
 - microcode
 - differences between HSS and LSS 5-9
 - summary 5-8
 - modem-in layer 5-13
 - modem-out layer 5-13
 - receive layers 5-13
 - transmit layers 5-12
- I**
- I-frame receive operation (FESH) 5-18
 - I/O
 - configuration data set (IOCDs) 7-8
 - error alert from CP 7-21
 - error alert from MOSS 7-21
 - IACK operation (TRM) 6-18
 - IBE ESS (initial status=B'110') 12-32
 - IBE HSS (initial status=B'110') 5-34
 - IBM Token-Ring network 6-4
 - ICB 12-12
 - ICF (internal clock function) 4-12, 4-50
 - LIC types 1 to 4 4-50
 - identification of the 3745 1-5
 - IEEE 802.3 frame 12-10
 - IML
 - definition 4-23
 - status of the HSS scanner after IML 5-14
 - status of the LSS scanner after IML 4-21
 - implicit allegiance 7-18
 - in mailbox 8-14
 - inbound/outbound RAM
 - addressing (FESA) 4-29
 - control (FESA) 4-29
 - external registers 4-29
 - inbound/outbound RAM (*continued*)
 - layout (FESA) 4-29
 - initial selection state (CA) 7-9
 - initial status = B'110' (internal box error ESS) 12-32
 - initial status = B'110' (internal box error HSS) 5-34
 - initial status field (ISF) bit definition 5-32
 - initial status field bit definition for ESS 12-30
 - initialized 4-19
 - inoperative 4-19
 - input and output X'7x' register bits (CCU) 2-28
 - input instructions
 - details (CCU) 2-25
 - input instructions (CCU) 2-23
 - input/output 3-7
 - input/output instruction formats (ELA) 12-25
 - input/output X'7x' instructions (CCU) 2-25
 - instantaneous allegiance 7-18
 - instruction
 - address register (CCU) 2-21, 2-42
 - instruction formats for input/output (ELA) 12-25
 - instruction set (CCU) 2-10
 - instruction summary (ELA IOH/IOHI) 12-26
 - interconnection
 - adapters interconnection errors (CCU) 2-47
 - bus control (TIC) 6-14
 - CCU-to-storage 2-17
 - DMA bus to FESH 5-11
 - errors (DMA) detected by FESH 5-24
 - errors (HSS CSP) 5-27
 - FESA-CSP 4-28
 - FESA-serial link 4-28
 - FESH to CSP 5-10
 - HSS internal interconnections 5-10
 - MOSS type errors 2-49
 - PCC 10-17
 - PCC card to MOSS 10-18
 - PCC card to control panel 10-19
 - PCC card to power supply signal 10-19
 - SCTL-to-CCU cache 2-16
 - TIC to bus 6-17
 - TRA IOC bus 6-16
 - interconnection errors (DMA) detected by EAC 12-38
 - interconnection errors (ELA CSP) 12-41
 - interface
 - check (HSS line) 5-28
 - check stop mode (adapter) (CCU) 2-48
 - communication interfaces of HSS 5-40
 - DCE to telephone line (LIC type 5) 4-63
 - FESH-DCE 5-40
 - LIC types 1 to 4 4-100
 - LIC types 1 to 4 lines 4-43
 - types (HSS) 5-7
 - X.21 (HSS) 5-41
 - interface control block 12-12
 - interface coupler (TIC) card 6-8

- interface disconnect 7-21
- interface or port types (ELA) 12-7
- interfaces
 - Ethernet LAN version 2 12-5
 - IEEE 802.3 12-5
- internal box error (IBE)
 - IBE reporting (HSS) 5-24
- internal box error (IBE) reporting (ELA) 12-37
- internal box error status ESS (initial status=B'110') 12-32
- internal box error status HSS (initial status=B'110') 5-34
- internal checkers (EAC) 12-42
- internal checkers (FESH) 5-28
- internal clock function
 - See ICF (internal clock function)
- internal interconnections
 - ELA 12-13
- internal mode (clocking) 4-50
- interrupt
 - CA 7-10
 - IACK operation (TRM) 6-18
 - request by the TIC (format 2) 6-22
- interrupt levels
 - ELA microcode 12-11
- interrupt request removed 3-7
- interrupts
 - level 1 (CCU) 2-8
 - level 1 interrupt reporting (CCU) 2-20
 - level 2 (CCU) 2-8
 - level 2 and level 3 interrupt reporting (CCU) 2-20
 - level 3 (CCU) 2-8
 - level 4 (CCU) 2-8
 - level 5 (CCU) 2-8
 - mechanism (CCU) 2-6
 - request determination (CCU) 2-7
 - request sources (CCU) 2-8
 - setting/resetting interrupt requests (CCU) 2-7
- interrupts (CCU) 2-6
- introduction
 - power control subsystem 10-15
 - power subsystem 10-4
 - to HSS 5-5
- introduction to ELA 12-5
- INV PATTERN RCV 4-90
- invalid OP-code (CCU) 2-47
- IOC
 - bus interconnection (TRA) 6-16
 - bus-to-CSP interconnection (ELA) 12-13
 - bus-to-CSP interconnection (HSS) 5-10
 - control logic (CCU) 2-20
 - data flow (CCU) 2-20
- IOC BER
 - See BER type 14
- IOC BER format 11-200

- IOC bus 3-4
 - physical interconnection 3-9
 - protocol 3-4
 - scoping routine 3-53
 - adapter selection 3-54
 - ERC meaning 3-56
 - error bit 3-56
 - examples 3-58
 - how to start 3-53
 - parameter description 3-54
 - RAC meaning 3-56
 - RACs generated 3-55
 - terminator connector pin assignment 3-60
- IOC bus and adapter errors 11-24
- IOCDS 7-8
- IOH/IOHI instruction summary (ELA) 12-26
- IPL
 - automatic 1-23
- IPL automatic 1-23
- IPL BER 11-33
- IPL error 11-67
- ISF bit definition 5-32
- ISF bit definition for ESS 12-30

K

- KEY n STUCK 4-79, 4-90
- keying procedures
 - on PKD 4-76

L

- LA addresses decoding 2-33
- LA bypass mechanism 3-48
- LA plugging rules 3-48
- lagging address register (CCU) 2-42
- lamp test
 - PKD 4-75
- LCB 12-12
- LCS 5-31
- LCS (ELA) 12-30
- LD
 - LIC type 6 4-86
- LDM LINE DOWN 4-90
- lead state confirmation
 - on V.35 modem-in leads (FESH) 5-19
 - on X.21 modem-in leads (FESH) 5-20
- level 1
 - error status register (TRM) 6-20
 - interrupt reporting (CCU) 2-20
 - interrupt request (CA) 7-16
- level 2
 - error status registers (TRM) 6-22
 - interrupt reporting (CCU) 2-20
- level 3
 - interrupt reporting (CCU) 2-20

- level 3 interrupt request (CA) 7-16
- level 5
 - I/O error (CCU) 2-47
- LIB1/LIB2/LIB3 4-8
- LIC (line interface coupler)
 - definition 4-9
 - disabled 4-31
 - enabled leads 4-31
 - LIC line analysis procedures 4-99
 - line weight 4-11
 - modem-in process for non X.21 lines 4-48
 - modem-in process for X.21 lines 4-48
 - reset 4-38, 4-42
 - serial link connection to LICs5/6 4-34
 - swap 4-46
- LIC board 1-10
 - definition 4-8
- LIC board addressing 3-38
- LIC boards 01L-A1 and 01L-A2 DC voltages and tolerances 10-12
- LIC boards 01M-A1 and 01M-A2 DC voltages and tolerances 10-12
- LIC type 4
 - personalization 4-48
- LIC type 5
 - configuration from PKD 4-77
 - multipoint 4-59
 - panel 4-65
 - point-to-point 4-58
 - PT2/3 connection 4-79
 - to 586X or 786X connection 4-58
 - to 586Xs connection 4-59
 - to LIC type 5 connection point-to-point 4-58
 - to LICs type 5 connection multipoint 4-59
 - to one tailed 586X connection multipoint 4-60
 - to tailed 586X connection 4-59
 - point-to-point 4-59
- LIC type 5 (DCE function)
 - alarm tone detection 4-72
 - backup speed 4-70
 - card EC level 4-70
 - carrier detector sensitivity 4-69
 - CCITT 4-70
 - CCITT mode 4-62, 4-63
 - configuration 4-73
 - configuration commands 4-70
 - configuration options 4-60
 - configurations 4-58
 - data encoding and modulation 4-61
 - data flow 4-57
 - DCE address 4-69
 - DCE to telephone line interface 4-63
 - default speed 4-69
 - host support 4-70
 - line quality threshold 4-69
 - line specifications 4-65
- LIC type 5 (DCE function) (*continued*)
 - line spectrum 4-65
 - LPDA-2 hit count threshold 4-69
 - LPDA*-2 enabled 4-70
 - maintenance approach 4-57
 - manual tests 4-72
 - microcode EC level 4-70
 - multipoint - LIC type 5 to 586Xs 4-59
 - multipoint - LIC type 5 to LICs type 5 4-59
 - multipoint - LIC type 5 to one tailed 586X 4-60
 - native mode 4-62, 4-63
 - options and configurations 4-67
 - point-to-point - LIC type 5 to 586X or 786X 4-58
 - point-to-point - LIC type 5 to LIC type 5 4-58
 - point-to-point - LIC type 5 to tailed 586X 4-59
 - point-to-point/multipoint 4-69
 - problem determination commands 4-70
 - receive level threshold 4-69
 - RFS delay 4-64
 - speed setting 4-58
 - speeds 4-57
 - surge protection 4-64
 - tone characteristics 4-72
 - transit time 4-64
 - transmit clock control 4-69
 - transmit level 4-69
 - TSS commands 4-71
- LIC type 6
 - plugging limitations 4-11
- LIC type 6 (DSU/CSU function)
 - alarm tone detection 4-87
 - configuration 4-89
 - configuration options 4-82
 - configurations 4-81
 - connection to US DDS 4-80
 - data flow 4-80
 - data format 4-82
 - DCE address 4-86
 - DDS loop 4-87
 - DSU/CSU configuration 4-88
 - DSU/CSU information 4-88
 - DSU/CSU to line interface 4-82
 - DSU/CSU/LD 4-86
 - host support 4-86
 - limited distance connection 4-80
 - line specifications 4-84
 - local loop back 4-89
 - maintenance 4-80
 - manual tests 4-91
 - modulation 4-82
 - network services 4-86
 - options and configurations 4-85
 - panel 4-84
 - PKD command rejection 4-89
 - PKD use 4-88
 - point-to-point/multipoint 4-86

- LIC type 6 (DSU/CSU function) *(continued)*
 - POR bring-up information 4-89
 - problem determination commands 4-86
 - PT2/3 4-91
 - RFS delay 4-83
 - speed change 4-89
 - speed control 4-86
 - speed setting 4-81
 - speeds 4-81
 - surge protection 4-82
 - timing sources 4-86
 - tone characteristics 4-87
 - tone reception 4-87
 - transit time 4-83
 - TSS commands 4-87
 - unsolicited messages 4-90
- LIC types 1 to 4
 - address register 4-47
 - cards 4-43
 - characteristics 4-9
 - control register 4-47
 - DTE clocking 4-9
 - enable clock mode 4-47
 - interface lines 4-43
 - interfaces and cables 4-100
 - Internal clock function (ICF) 4-50
 - line enable/disable 4-44
 - line interface 4-9
 - logical addressing 4-46
 - loop 1 on V.24 4-51
 - loop 1 on V.25 4-52
 - loop 1 on X.21 4-52
 - loop 3 on V.24 4-52
 - loop 3 on X.21 4-52
 - protocols 4-9
 - reset 4-44
 - RTS 4-48
 - selective scanning 4-45
 - swap 4-46
 - transfer mode 4-9
 - transmission speed 4-9
 - transmit/receive mechanism 4-44
 - wraps 4-51
- LIC types 1 to 4 clocking
 - 3745 mode 4-51
 - direct mode 4-51
 - external mode 4-51
 - internal mode 4-50
- LIC types 1, 2 and 3
 - transmit clock gating by RFS 4-48
- LIC types 5/6
 - characteristics 4-11
 - DTE clocking 4-11
 - line interface 4-11
 - protocols 4-11
 - transfer mode 4-11
- LIC types 5/6 *(continued)*
 - transmission speed 4-11
- LIC types 5/6 DTE function
 - address register 4-55
 - control register 4-55
 - LIC reset 4-54
 - line enable/disable 4-55
 - loop 3 on V.24 4-56
 - selective scanning. 4-55
 - swap 4-55
 - transmit/receive mechanism 4-54
 - wraps 4-55
- LIC1 LIC3 LIC4A and LIC4B addressing 3-40
- LIC5 and LIC6 addressing 3-42
- limited distance
 - LIC type 6 connection 4-80
 - line specifications 4-84
 - speed for LIC type 6 4-81
- line adapter addressing (LSS, ELA, and HSS) 3-34
- line adapter bypass mechanism 3-48
- line adapter plugging rules 3-48
- line addressing 3-39
- line characteristics
 - 3002 channel (US) 4-66
 - France 4-67
 - Japan 4-67
 - M.1020 4-66
 - M.1025 4-66
 - UK 4-67
- line clocking (HSS) 5-42
- line communication status
 - ELA 12-30
- line communication status (LCS) 5-31
- line control block 12-12
- line enable/disable
 - LIC types 5/6 (DTE function) 4-55
- line function 3-6
 - address/command tag 3-7
 - CA IPL detect 3-8
 - cycle steal grant high 3-7
 - cycle steal grant low 3-7
 - cycle steal request high 3-7
 - cycle steal request low 3-7
 - data bus bytes 0 and 1 3-9
 - data tag 3-7
 - DMA-to-SCTL bus 3-11
 - halt 3-8
 - input/output 3-7
 - interrupt request removed 3-7
 - modifier 3-8
 - out (R/W) 3-8
 - parity valid 3-8
 - reset 3-9
 - scanner interrupt 3-9
 - valid byte 3-8
 - valid halfword 3-8

- line identification (line ID) generation (TRA) 6-23
- line interface
 - LIC types 1 to 4 4-9
 - LIC types 5/6 4-11
- line interface address
 - asynchronous operation command 4-29
 - FESA X'13' register 4-29
- line interface check (HSS) 5-28
- line interface coupler
 - See LIC (line interface coupler)
- line interface couplers 1-11
- line quality threshold
 - LIC type 5 (DCE function) 4-69
- line specifications
 - LIC type 5 (DCE function) 4-65
 - LIC type 6 4-84
- line spectrum
 - LIC type 5 (DCE function) 4-65
 - native 4-65
 - V.27 bis 4-65
 - V.29 4-65
 - V.33 4-66
- line weight
 - LIC 4-11
- Link Problem Determination Aid
- LLAP
 - See LIC (line interface coupler), LIC line analysis procedures
- local
 - attachment (HSS) 5-42
 - status 4-98
- local console 9-6
- local loop
 - from PKD 4-77
- local self-test
 - LIC type 5 4-96
 - LIC type 6 4-97
- local storage
 - CSP 4-15
- local storage parity error (CCU) 2-46
- logical adapter address 3-31
- logical addressing
 - LIC types 1 to 4 4-46
- long-term allegiance 7-18
- loop
 - (local) from PKD 4-77
 - DDS, LIC type 6 4-87
- loop 1
 - on V.24 (LIC types 1 to 4) 4-51
 - on V.25 (LIC types 1 to 4) 4-52
 - on X.21 (LIC types 1 to 4) 4-52
- loop 2
 - remote loop back (LIC 5/6) 4-96
- loop 3
 - LIC type 6 4-87
 - local loop back (LIC 5/6) 4-96

- loop 3 (*continued*)
 - on V.24 (LIC types 1 to 4) 4-52
 - on V.24, LIC types 5/6 (DTE function) 4-56
 - on X.21 (LIC types 1 to 4) 4-52
- loop back
 - local, LIC type 6 4-89
- loop or wrap tests for HSS V.35 and X.21 5-39
- loosely coupled 7-17
- low-speed scanner 1-9
 - See also LSS (low-speed scanner)
- LPDA-2
 - enabled (LIC type 5) 4-70
 - hit count threshold (LIC type 5) 4-69
- LSS (low-speed scanner)
 - definition 4-7
- LSSD
 - data flow 8-17
 - operation 8-17
 - testing circuit 8-17

M

- M.1020 line characteristics 4-66
- M.1025 line characteristics 4-66
- mailbox 8-13, 8-14
- mailbox commands 8-15
- main line survey 10-26
- main storage (CCU) 2-13
- main storage protection state (CCU) 2-18
- mains voltage
 - adjustment 10-5
 - limits 10-5
- maintenance 1-24
 - console 9-8
 - LIC type 5 (DCE function) 4-57
 - LIC type 6 4-80
- maintenance and operator subsystem 1-15
- maintenance temporary address register (MTAR) (CCU) 2-43
- maintenance temporary data register (MTDR) (CCU) 2-43
- Manchester encoding
 - description 4-35
 - SMUX 4-39
- MAND DDS LOOP 4-90
- manual BER file correlation
 - See BER analysis
- manual test
 - from PKD (LIC types 5/6) 4-95
 - LIC type 5 (DCE function) 4-72
- manual V.35/X.21 wrap or loop tests 5-39
- manual versus scheduled power ON 10-24
- MAU 12-5
- MCTL and ECC (CCU) 2-15
- media adapter unit 12-5

- messages
 - unsolicited (PKD), LIC type 6 4-90
- microcode
 - differences between HSS and LSS 5-9
 - EAC 12-13
 - exchange between CLDP-HSS 5-10
 - exchange between NCP-ELA 12-13
 - exchange between NCP-HSS 5-10
 - functions (HSS) 5-15, 5-17
 - of the FESH 5-10
 - service aid (HSS) 5-37
 - service aids (ELA) 12-45
- microcode EC level
 - LIC type 5 (DCE function) 4-70
- minimum configuration 1-6
- MIOC interconnection (CCU) 2-12
- MIOC parity error (CCU) 2-46
- MMIO operation (TRA) 6-17
- modem and data management (HSS) 5-11
- modem interface management (FESH) 5-19
- modem retrain (FESH) 5-21
- modem-in 4-32
 - layer (HSS CSP) 5-13
 - lead state confirmation
 - on V.35 (FESH) 5-19
 - on X.21 (FESH) 5-20
 - management (FESH) 5-19
- modem-out 4-33
 - layer (HSS CSP) 5-13
 - management (FESH) 5-20
- modes of operation
 - CA 7-8
- modifier 3-8
- modulation
 - LIC type 6 4-82
- MOSS 1-15
 - address exception error 2-49
 - changes of state 8-9
 - data operand register (MDOR) parity error (CCU) 2-46
 - error status register (TRA) 6-24
 - functions 8-8
 - interconnection type errors 2-49
 - OP error 2-49
 - packaging 8-4
 - processor 8-4
 - reset 8-5
 - screen address display CA 3-33
 - screen address display LA 3-35
 - states 8-9
 - to and from CCU 2-43
- MOSS BER 11-9
 - See also* BER type 01
- MOSS BER formats 11-112
- MOSS board DC voltages and tolerances 10-10
- MOSS check 11-30
- MOSS check codes 11-40
- MOSS ID 06 formats 11-33
- MOSS-to-CCU communication 8-14
- MOSS/disk/diskette drive interaction 8-19
- MOSS/operator console connections 8-20
- MSAU (TRSS) 6-6
- multi-floor wiring example 6-9
- multipoint
 - LIC type 5 (DCE function) 4-69
 - LIC type 5 to 586Xs connection 4-59
 - LIC type 5 to LICs type 5 connection 4-59
 - LIC type 5 to one tailed 586X 4-60
 - LIC type 6 4-86
- multistation access unit, (TRSS) 6-6
- MUX (multiplexer card)
 - data flow 4-36
 - definition 4-8

N

- native mode
 - LIC type 5 (DCE function) 4-62, 4-63
- NCP 1-22, 1-23
 - buffer handling logic checker 5-28
 - buffer prefix validity checking in receive (HSS) 5-37
 - commands (HSS) 5-7
 - to HSS microcode exchange 5-10
 - NCP buffer prefix validity checking in receive (ELA) 12-45
 - NCP commands (ELA) 12-7
 - NCP definition facility
 - See* NDF
 - NCP-ELA microcode exchange 12-13
 - NCP/PEP BER
 - See* BER type 12
 - NCP/PEP BER formats 11-193
 - NDF 1-23
 - NEF 1-23
 - NetView*
 - facilities 1-21
 - Performance Monitor (NPM) 1-21
- network
 - management 1-21
 - Network Control Program 1-22
 - Network Extension Facility, IBM
 - See* NEF
 - Network Routing Facility
 - See* NRF
 - network services
 - LIC type 6 4-86
 - Network Terminal Option
 - See* NTO
 - no response
 - on PKD 4-76

- nodes (TRSS) 6-8
- non X.21 lines
 - modem-in process 4-48
- Non-SNA Interconnection, IBM
 - See NSI
- normal tagged status 7-18
- not executed
 - PKD command 4-76
- NPSI 1-22
- NRF 1-22
- NSC mode 7-8
- NSI 1-23
- NTO 1-22
- numbering (CA) 7-5

O

- operating systems 1-20
- operation register (CCU) 2-42
- operator address register (CCU) 2-43
- operator consoles 1-17
 - 3746-900 console 9-8
 - alternate console 9-6
 - console sharing via IBM 7427 9-7
 - highlights 9-6
 - local console 9-6
 - remote console 9-6
 - remote support facility 9-7
- operator function select value register (CCU) 2-43
- OPT DDS LOOP 4-90
- options
 - LIC type 5 (DCE function) 4-67
 - LIC type 6 4-85
- opto-coupler device output 10-27
- out (R/W) 3-8
- out mailbox 8-14
- output instructions
 - CCU 2-24
 - details (CCU) 2-26

P

- packaging
 - CA 7-4
 - ELA 12-5
 - MOSS 8-4
- Packet Switching Interface, NCP
 - See NPSI
- panel
 - LIC type 5 4-65
 - LIC type 6 4-84
- parameter status area 12-12
- parameter/status area
 - ELA 12-25
 - layout (ELA) 12-29

- parity valid 3-8
- path POR
- PEP 1-22
- performance test points 2-50
- personalization
 - LIC type 4 4-48
- physical address wiring 3-31
- physical interconnection
 - DMA bus 3-10
 - IOC bus 3-9
- physical link status definition 11-208
- pin assignment (bus terminator) 3-60
- ping/pong buffers 4-18
 - clocks 4-18
- PIO
 - operation sequence 3-15
 - data transfer 3-17
 - initialization 3-16
 - read (halfword adapter) 3-18
 - write (halfword adapter) 3-18
- PKD (portable keypad display)
 - analog test 4-77
 - background information 4-75
 - background information (LIC type 6) 4-88
 - bad response 4-76
 - busy TC on 4-76
 - buzzer control 4-78
 - command not executed 4-76
 - command rejection 4-76
 - commands in CE mode 4-78
 - contact sense/operate 4-78
 - DCE information 4-75
 - description 4-74
 - digital test 4-77
 - keying procedures 4-76
 - lamp test 4-75
 - LIC type 5 configuration 4-73, 4-77
 - local loop 4-77
 - manual tests LIC type 5 (DCE function) 4-72
 - no response 4-76
 - POR bring-up information 4-76
 - self-tests 4-77
 - speed change 4-77
 - status display 4-77
 - unsolicited messages 4-79
- PLM status definition 11-208
- plugging limitations
 - LIC type 6 4-11
- plugging rules for LAs or CAs 3-48
- point-to-point
 - LIC type 5 (DCE function) 4-69
 - LIC type 5 to 586X or 786X 4-58
 - LIC type 5 to LIC type 5 4-58
 - LIC type 5 to tailed 586X 4-59
 - LIC type 6 4-86

POP parity error (CCU) 2-46

POR

- CCU subsystem 2-13
- MOSS 8-5
- path 10-29
- pin location 10-29
- principle 10-29
- storage control (CCU) 2-13

POR - bring-up

- information (on PKD) 4-76
- information, LIC type 6 4-89

POR (power ON reset)

- CSP 4-20
- FES 4-25

port or interface types (ELA) 12-7

portable keypad display

- See PKD (portable keypad display)

power reset function 10-25

power BER

- See BER type 04

power BER formats 11-132

power connection to the 3746-900 10-34

power control for customer 9-7

power control subsystem 10-15

- data flow 10-16
- introduction 10-15

power input limitation

- adjustment 10-5
- limits 10-5

power mode of operation 10-20

- host mode 10-20
- local mode 10-20
- network mode 10-20
- switching from one mode to another. 10-21

power OFF sequence. 10-23

power ON

- reset (TRA) 6-19

power ON reset 4-20

power ON retry

- function 10-24
- sequence 10-24

power ON sequence 10-22

power ON/OFF 1-19

power stacked faults 10-28

- faults logging 10-28

power status monitoring 10-24

power subsystem

- introduction 10-4

presentation of status 7-19

preventive maintenance 1-24

primary power box

- component location 10-6
- distribution 10-7

problem determination

- aid for LIC types 1 to 4 4-92
- aid for LIC types 5/6 4-95

problem determination (*continued*)

- aid on HSS 5-37
- aid on TRA 6-27
- aids (ELA) 12-45
- CCITT loop 3 4-87
- commands, LIC type 5 (DCE function) 4-70
- commands, LIC type 6 4-86
- programming support (ELA) 12-45
- programming support (HSS) 5-37
- self-test 4-87

problem isolation and network management (HSS) 5-38

processor unit (CCU) 2-4

program display register 1 (CCU) 2-43

program display register 2 (CCU) 2-43

program errors (CCU) 2-47

program levels

- level 1 (CCU) 2-5
- level 2 (CCU) 2-5
- level 3 (CCU) 2-6
- level 4 (CCU) 2-6
- level 5 (CCU) 2-6
- masking priorities (CCU) 2-6
- priorities (CCU) 2-5

program/hardware checks (ELA) 12-36

program/hardware errors (HSS) 5-23

programmed reset

- FES 4-26
- TRA 6-19

programming support

- coexistence/migration 1-23
- for problem determination (HSS) 5-37
- in controller 1-20
- in network 1-21

programming support for problem determination (ELA) 12-45

protocol

- LIC types 1 to 4 4-9
- LIC types 5/6 4-11
- of the token-ring access 6-7

protocol of IOC buses 3-4

PS1

- component locations 10-9
- connection layout 10-8
- DC voltage test points 10-9
- DC voltages and tolerances 10-10

PS2

- connection layout 10-13
- DC voltages and tolerances 10-13

PSA 12-12

PSA (ELA) 12-25

PSA layout (ELA) 12-29

PT2/3

- connection to LIC type 5 4-79
- LIC type 6 4-91

PUC 2-4
oscillator interconnection (CCU) 2-12

R

RAM A 4-24
RAM B 4-24
RAM C 4-24
RAM organization
FESA 4-28
read PIO example 3-4
read/write operations 8-20
ready state (CA) 7-9
receive
command FESH 5-17
continue command (FESH) 5-18
end of receive (FESH) 5-18
flow (FESH) 5-18
layers (HSS CSP) 5-13
level threshold for LIC type 5 (DCE function) 4-69
operation (TRA) 6-14
operation for I-frame (FESH) 5-18
operation HSS 5-17
reception of data (HSS) 5-11
reference code 11-10, 11-18, 11-21
reference code generation 11-16
register
A (CCU) 2-20
adapter check (TIC) 6-24
CCU 2-21
D (CCU) 2-20
data value register (CCU) 2-43
external (CCU) 2-21
general (CCU) 2-21
hardware registers (CCU) 2-42
instruction address (CCU) 2-21, 2-42
lagging address register (CCU) 2-42
maintenance temporary address register (MTAR)
(CCU) 2-43
maintenance temporary data register (MTDR)
(CCU) 2-43
operation (CCU) 2-42
operator address (CCU) 2-43
operator function select value register (CCU) 2-43
program display register 1 (CCU) 2-43
program display register 2 (CCU) 2-43
storage address (CCU) 2-42
registers (CA) 7-10
REM DSU/CSU FAILED 4-90
REM MODEM FAILED 4-79
REM PWR LOSS 4-79, 4-90
remote
self-test 4-97
status 4-98
remote console 9-6

Remote Support Facilities (RSF) 8-20
remote support facility 1-17, 9-7
removing CA from CS chain 7-14
reporting DMA errors 5-26, 12-40
request unit 8-16
reset 3-9
AIO (CCU) 2-21
CSP 4-20
DMUX 4-37
EAC 12-17
FESH 5-15
FESL 4-25
LIC 4-38, 4-42
LIC types 1 to 4 4-44
LIC types 5/6 (DTE function) 4-54
power ON and tag reset (TRA) 6-19
programmed (TRA) 6-19
programmed reset PIO 4-20
SMUX 4-42
TIC 6-19
reset and set the bypass CCU check stop mode 2-44
resetting interrupt requests (CCU) 2-7
RESP field in power BER 11-131
RESP/REQ in power BER 11-129
RFS 4-32
delay, LIC type 5 (DCE function) 4-64
delay, LIC type 6 4-83
transmit clock gating 4-48
RI 4-32
ring
access protocol (TRSS) 6-7
RLSD 4-32
ROS (read-only storage)
CSP 4-15
RSF 1-17, 9-7
RTAM 1-20
RTS
LIC types 1 to 4 4-48
rules of configuration BPC1/BPC2 cards 3-29

S

safety
statement 10-5
safety,
general xi
notices xi
service inspection procedures xi
SAR parity error (CCU) 2-46
scanner errors with no BER 11-24
scanner interrupt 3-9
scanner states
connected 4-19
disconnected 4-19
disconnected-stop 4-19
initialized 4-19

- scanner states (*continued*)
 - inoperative 4-19
 - running 4-19
 - stopped 4-19
- scanner status after IML (HSS) 5-14
- scanner status after IML (LSS) 4-21
- SCF (ELA) 12-29
- SCF bit definition 5-31
- scheduled power ON function 10-23
- scoping routine for IOC bus 3-53
- SCTL 2-14
 - function partitioning 2-15
- SCTL card detected errors reported by FESH 5-26
- SCTL-to-CCU cache interconnection 2-16
- SCTL-to-DMA bus line function 3-11
 - byte select 3-12
 - data bus 3-12
 - EAC clock 3-12
 - errors 3-12
 - FESH clock 3-12
 - grant 3-12
 - read/write 3-12
 - ready 3-12
 - request 3-12
 - SCTL clock 3-12
 - turnaround 3-12
 - valid 3-12
- SCTL/switch card detected errors reported by EAC 12-39
- secondary status field (SES) bit definition 5-31
- selective reset on CA 7-20
- selective scanning
 - configuration 4-46
 - LIC types 1 to 4 4-45
 - LIC types 5/6 (DTE function) 4-55
- SELF TEST FAILED 4-79, 4-90
- SELF TEST OK 4-79, 4-90
- self-test
 - LIC type 5 (DCE function) 4-71
 - LIC type 6 4-87
 - local (LIC type 5) 4-96
 - local (LIC type 6) 4-97
 - PKD 4-77
 - remote 4-97
- sensitivity
 - carrier detector (LIC type 5) 4-69
- serial link 4-13
 - connection to LICs 5/6 4-34
 - FESA interconnection 4-28
 - frames 4-34
- service aid
 - ELA 12-45
 - HSS microcode 5-37
- service personnel definitions xiii
- service processor 9-8
- SES bit definition 5-31
- set and reset the bypass CCU check stop mode 2-44
- set and reset the level 1 adapter mask (CCU) 2-44
- set line vector table
 - high (ELA) 12-27
 - low (ELA) 12-27
- set special line vector table
 - high (ELA) 12-28
 - low (ELA) 12-28
- setting interrupt requests (CCU) 2-7
- setup of the console 9-8
- short hold mode/multiple port sharing 1-22
- signals used by CA 7-11
- single multiplexer card
 - See SMUX (single multiplexer card)
- SIT
 - ELA 12-45
- slot
 - control slots 4-35
 - data slots 4-34
 - in serial link 4-34
- SMUX (single multiplexer card)
 - card replacement 4-40
 - data flow 4-40
 - definition 4-9
 - functional description 4-42
 - functions 4-39
 - reset 4-42
 - transmit level 4-39
- SNA Interconnection (XI), X.25 1-22
- soft stop transmit command (HSS) 5-16
- SP/AE
 - address exception (CCU) 2-19
 - address exception key (CCU) 2-19
 - instructions (CCU) 2-19
 - key locations (CCU) 2-19
 - keys (CCU) 2-19
 - read only key (CCU) 2-19
 - storage protection (CCU) 2-19
 - storage protection key (CCU) 2-19
 - user key (CCU) 2-19
- specific mechanism 11-12
- speed
 - change from PKD 4-77
 - change, LIC type 6 4-89
 - control, LIC type 6 4-86
 - LIC type 5 (DCE function) 4-57
 - LIC type 6 4-81
 - setting, LIC type 5 (DCE function) 4-58
 - setting, LIC type 6 4-81
- SSP 1-20
- start line (ELA) 12-27
- start line initial (ELA) 12-27
- state
 - CA 7-9

- state confirmation
 - on CTS lead (FESH) 5-20
 - on X.21 modem-in lead (FESH) 5-20
- status
 - display on PKD 4-77
 - local 4-98
 - remote 4-98
- status control field (ELA) 12-29
- status control field (SCF) bit definition 5-31
- status fields SCF, SES, LCS 5-31
- status of the HSS scanner after IML 5-14
- status of the LSS scanner after IML 4-21
- status transfer state (CA) 7-10
- stop 2-21
 - AIO (CCU) 2-21
 - receive command (FESH) 5-18
- storage
 - address exception (CCU) 2-19
 - address register (CCU) 2-42
 - basic card (CCU) 2-4
 - CACHE (CCU) 2-17
 - CCU 2-13
 - control (CCU) 2-14
 - control card (SCTL) (CCU) 2-4
 - control interconnection (CCU) 2-12
 - control mode (CCU) 2-16
 - environment (CCU) 2-14
 - instructions (CCU) 2-19
 - line invalidation (CCU) 2-18
 - protect (CCU) 2-19
 - protection (CCU) 2-18
 - protection state (CCU) 2-18
 - read policy (CCU) 2-18
 - word (CCU) 2-13
 - write policy (CCU) 2-18
- storage protect
 - and address exception instructions (CCU) 2-19
 - instruction fetch error (CCU) 2-47
 - program execution error (CCU) 2-47
- summary of the IOC bus interface signal lines 6-17
- surge protection
 - LIC type 5 4-64
 - LIC type 6 4-82
- swap
 - LIC types 1 to 4 4-46
 - LIC types 5/6 (DTE function) 4-55
- switches setting
 - SMUX 4-40
- system components (TRSS) 6-7
- system environment (ELA) 12-5
- system environment (HSS) 5-5
- system reset on CA 7-19
- system support programs 1-20

T

- tag reset (TRA) 6-19
- tag sequence (DMA) 5-24, 12-38
- tagged DE status 7-18
- tail gate for consoles 9-7
- TD fields (ELA) 12-26
- test
 - analog line analysis 4-99
 - digital (xmit/rcve) LIC type 5 4-98
 - digital (xmit/rcve) LIC type 6 4-99
 - manual from PKD (LIC types 5/6) 4-95
 - manual, LIC type 6 4-91
 - PKD 4-77
- TEST FAILED 4-79, 4-90
- TEST FROM HOST 4-79, 4-90
- TEST OK 4-79, 4-90
- TEST OK NOWRP 4-79, 4-90
- TEST OK WRAP 4-79, 4-90
- test points for performance 2-50
- thresholds 11-5
- TI 4-33
- TIC 6-8
- TIC (token-ring interface coupler)
 - adapter check register 6-24
 - bus interconnection 6-17
 - bus interconnection control 6-14
 - bus signal lines summary 6-18
 - card 6-12
 - data flow 6-12
 - reset 6-19
- time out
 - DMA 5-25
 - values used by the HSS 5-22
- time out (DMA) 12-38
- timers (CCU) 2-19
- timing
 - LIC type 6 4-86
- token-ring
 - access control protocol 6-7
 - adapter (TRA) 6-5, 6-10
 - adapter addressing 3-46
 - address 3-47
 - bridges 6-8
 - cabling system 6-5
 - frame format 6-7
 - interconnection function, (NCP) 1-22
 - interface coupler (TIC) card 6-8, 6-12
 - line addressing 3-47
 - multiplexor (TRM) card 6-15
 - network 6-4
 - wrap tests (TRA) 6-27
- token-ring subsystem 1-14
- token-ring subsystem (TRSS) 6-1
- tone
 - alarm tone detection (LIC type 5, DCE function) 4-72

tone (*continued*)
 characteristics (LIC type 5, DCE function) 4-72
 characteristics, LIC type 6 4-87
 reception, LIC type 6 4-87

tone detection
 alarm, LIC type 6 4-87

TPF 1-23

TPS
 alternate path 7-17
 contingent allegiance 7-18
 implicit allegiance 7-18
 instantaneous allegiance 7-18
 long-term allegiance 7-18
 neutral 7-18
 states of allegiance 7-18
 switched 7-18

TPS/TCS mode 7-17

TRA (token-ring adapter)
 functions 6-5
 in the 3745 6-10
 IOC bus interconnection 6-16
 receive operation 6-14
 resets 6-19
 transmit operation 6-15

Transaction Processing Facility, IBM
 See TPF

transfer mode
 LIC types 1 to 4 4-9
 LIC types 5/6 4-11

transit time
 LIC type 5 (DCE function) 4-64
 LIC type 6 4-83

transmission of data (HSS) 5-10

transmission speed
 LIC types 1 to 4 4-9
 LIC types 5/6 4-11

transmission subsystem 1-9
 See also TSS (transmission subsystem)

transmit
 command (HSS) 5-16
 initial command (HSS) 5-15
 operation
 TRA 6-15
 operation (HSS) 5-15

transmit clock control
 LIC type 5 (DCE function) 4-69

transmit level
 LIC type 5 (DCE function) 4-69
 SMUX 4-39
 switches setting 4-40

transmit/receive
 LIC types 1 to 4 4-44

TRM (token-ring multiplexor)
 arbitration mechanism 6-18
 card 6-15
 error detected by TRM (format 1) 6-22

TRM (token-ring multiplexor) (*continued*)
 error status
 register (level 1) 6-20
 register (level 2) 6-22

TRSS 1-14
 cabling system 6-5
 cpackaging (TRSS) 6-10
 major system components 6-7
 nodes 6-8
 ring 6-5
 ring access protocol 6-7

TRSS BER
 See BER type 15

TRSS BER formats 11-208

TSS 1-9
 interface cables 4-100

TSS (transmission subsystem)
 definition 4-6

TSS commands
 CCITT loop 3 4-71
 LIC type 5 (DCE function) 4-71
 LIC type 6 4-87
 self-test 4-71

TSS line addressing 3-41

TSS/HPTSS BER
 See BER type 11

TSS/HPTSS BER formats 11-189

two-processor switch (TPS) 7-17

U

UCW 7-8

unit control word (UCW) 7-8

unresolved error on:
 IOC bus 11-28
 scanner adapter 11-26
 scanner AIO 11-26

unresolved interrupts on:
 CA adapter error 11-25
 CA data/status 11-25
 CCU level 1 11-26
 CCU level 3 11-27
 CCU level 4 router 11-27
 level 1 CA 11-25
 level 2, scanner 11-26
 level 3 11-25, 11-26
 PCI 11-28
 scanner level 2 11-26

untagged asynchronous status 7-19

V

V.24
 loop 1 (LIC types 1 to 4) 4-51
 loop 3 (LIC types 1 to 4) 4-52
 loop 3, LIC types 5/6 (DTE function) 4-56

V.25
loop 1 (LIC types 1 to 4) 4-52

V.35
and X.21 example of cables connected (HSS) 5-41
and X.21 wrap or loop tests (HSS) 5-39
example of two cables connected (HSS) 5-41
modem-in lead state confirmation (FESH) 5-19
valid byte 3-8
valid halfword 3-8
VTAM* 1-20

W

wrap
external facility (HSS) 5-38
LIC types 1 to 4 4-51
LIC types 5/6 (DTE function) 4-55
mode at DCE level (HSS) 5-38
or loop tests (HSS) 5-39
token-ring wrap tests (TRA) 6-27
wrap plugs 7-23
wrap tests
controlled from host 4-93, 4-95
LIC types 1 to 4 4-93
LIC types 5/6 4-95
controlled from MOSS 4-94, 4-95
LIC types 1 to 4 4-94
LIC types 5/6 4-95
WRONG SLOT 4-79, 4-90

X

X'13' register
FESA line interface address 4-29
X'15' register
FESA asynchronous operation command 4-29
X'75' register LA/CA addresses decoding 2-33
X.21
clear 4-33
example of two cables connected (HSS) 5-41
interface (HSS) 5-41
loop 1 (LIC types 1 to 4) 4-52
loop 3 (LIC types 1 to 4) 4-52
modem-in lead state confirmation (FESH) 5-20
X.21 lines
ICF data flow 4-50
modem-in process 4-48
X.21 SH/MPS 1-22
X.25 SNA Interconnection (XI) 1-22
xmit/rcve
digital test, LIC type 5 4-98
digital test, LIC type 6 4-99

Z

Z register parity error (CCU) 2-46

Readers' Comments — We'd Like to Hear from You

**IBM 3745 Communication Controller
Models 130, 150, 160, 170 and 17A
Hardware Maintenance Reference**

Publication No. SY33-2066-4

Please send us your comments concerning this book. We will greatly appreciate them and will consider them for later releases of the present book.

If you prefer sending comments by FAX or electronically, use:

- FAX: 33 4 93 24 77 97
- E-mail: FRIBMQF5 at IBMMAIL
- IBM Internal Use: LGERCF at LGEPROFS
- Internet: rcf_lagaude@vnet.ibm.com

In advance, thank you.

Your comments:

Name

Address

Company or Organization

Phone No.



Fold and Tape

Please do not staple

Fold and Tape

PLACE
POSTAGE
STAMP
HERE

IBM France
Centre d'Etudes et Recherches
Service 0798 - BP 79
06610 La Gaude
France

Fold and Tape

Please do not staple

Fold and Tape



Part Number: 03F5010

Printed in Denmark by IBM Danmark A/S

